

SEE STAIR DETAILS ON FABRICATION SHEETS E-4 & E-5

SHOWROOM AREA

ELECT. RISER AREA

FUTURE R/R FUTURE R/R

OFFICE NO. 2

OFFICE NO. 3

BREAK ROOM

CONFERENCE RM.

SHOWROOM AREA





OFFICE NO. 5

OFFICE NO. 4

OFFICE NO. 1

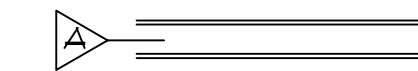
1 MAIN FLOOR PLAN  
A-3.1 SCALE: 1/4" = 1'-0"

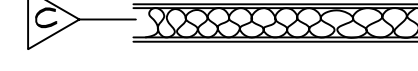
PARTITION PLAN LEGEND

-  NEW NON-LOAD WALL CONSTRUCTION  
3-5/8" METAL STUDS TO DECK WITH  
1/2" GYP. BD. EACH SIDE
-  NEW SOFFIT DROP CONSTRUCTION  
3-5/8" METAL STUDS @ 12" O.C. WITH  
1/2" GYP. BD. EACH SIDE
-  TYPICAL WALL CONSTRUCTION WITH  
SOUND INSULATION
-  TYPICAL STOREFRONT GLASS WALL  
PARTITION. TEMPERED GLASS IN AN  
ALUMINUM FRAME - 8'-0" HIGH UNITS

**DOOR HARDWARE**

DOOR SCHEDULE NO.  
HARDWARE  
DOOR STYLE

**HARDWARE INFORMATION:**  
1 HARDWARE - PRIVACY/LOCK SET  
2 HARDWARE - PASSAGE SET  
3 HARDWARE - PUSH/PULL

The Owner and Contractor shall release the Architect from and against all claims, damages, losses, and expenses, including attorney's fees arising out of or resulting from performance of the work by the contractor.

All work and materials shall meet the requirements of the local and state building codes and the specifications of the National Board of Fire Underwriters.

Changes to the plans by the Owner and Contractor shall be the responsibility of the persons making such changes.

Contractor shall check and verify all plan dimensions and conditions before proceeding with construction.

Do not scale drawings. All written dimensions shall govern.

These drawings are the property of the Architect and shall not be used without written permission.

revision	date
For Review	6/16/22
Revised	6/21/22
Revised	6/22/22
Revised	7/19/22
Final Plan	1/23/23

stamp

SEALED 2022

Job no. 06142022  
date 2022  
For Construction  
printed 1/23/2023

PLANS FOR A  
**SHELL BUILDING**  
115 HICKORY SPRINGS INDUSTRIAL DRIVE  
HOLLY SPRINGS GEORGIA

Floor Plans

sheet no.  
A-3.1