

4981 SW 74 Ct

2,350 +/- Sq Ft Office

Gateway Office Tech Business Park



4981 SW 74th Ct

Office with Air-Conditioned Warehouse

SIZE

2,350 +/- Square Feet

PRICE: \$21/SF Gross + Tax/Month

DESCRIPTION

This well-appointed office space offers a professional and functional environment ideal for businesses of all sizes. The two-story layout features a welcoming reception area that sets the tone for your clients and guests.

- Four private offices provide ample room for individual workspaces or small teams.
- A spacious conference room is perfect for meetings and presentations.
- Two bathrooms, one with shower—one on each floor—ensure convenience for staff and visitors.
- One kitchenette.
- 900+/- SF air-conditioned warehouse with rear-loading, overhead door.
- Six parking spaces make it easy for employees and clients to access the building.

This office space combines functionality with style, providing a great location for any business. Contact us today to schedule a tour!



SUBJECT PROPERTY

BIRD ROAD
Design District



SCOTT WESTON
JOSEPH WESTON

MADDUX AND COMPANY
7250 SW 39th Terrace,
Miami, FL 33155
Office: 305.264.9661

JOSEPH WESTON
Jweston@madduxco.com
305.510.2298

SCOTT WESTON
jscottweston@aol.com
786.942.6143



SUBJECT PROPERTY

BIRD ROAD
Design District



SCOTT WESTON
JOSEPH WESTON

MADDUX AND COMPANY
7250 SW 39th Terrace,
Miami, FL 33155
Office: 305.264.9661

JOSEPH WESTON
Jweston@madduxco.com
305.510.2298

SCOTT WESTON
jscottweston@aol.com
786.942.6143



SUBJECT PROPERTY

BIRD ROAD
Design District



SCOTT WESTON
JOSEPH WESTON

MADDUX AND COMPANY
7250 SW 39th Terrace,
Miami, FL 33155
Office: 305.264.9661

JOSEPH WESTON
Jweston@madduxco.com
305.510.2298

SCOTT WESTON
jscottweston@aol.com
786.942.6143



SUBJECT PROPERTY

BIRD ROAD
Design District



SCOTT WESTON
JOSEPH WESTON

MADDUX AND COMPANY
7250 SW 39th Terrace,
Miami, FL 33155
Office: 305.264.9661

JOSEPH WESTON
Jweston@madduxco.com
305.510.2298

SCOTT WESTON
jscottweston@aol.com
786.942.6143



SUBJECT PROPERTY

BIRD ROAD
Design District



SCOTT WESTON
JOSEPH WESTON

MADDUX AND COMPANY
7250 SW 39th Terrace,
Miami, FL 33155
Office: 305.264.9661

JOSEPH WESTON
Jweston@madduxco.com
305.510.2298

SCOTT WESTON
jscottweston@aol.com
786.942.6143

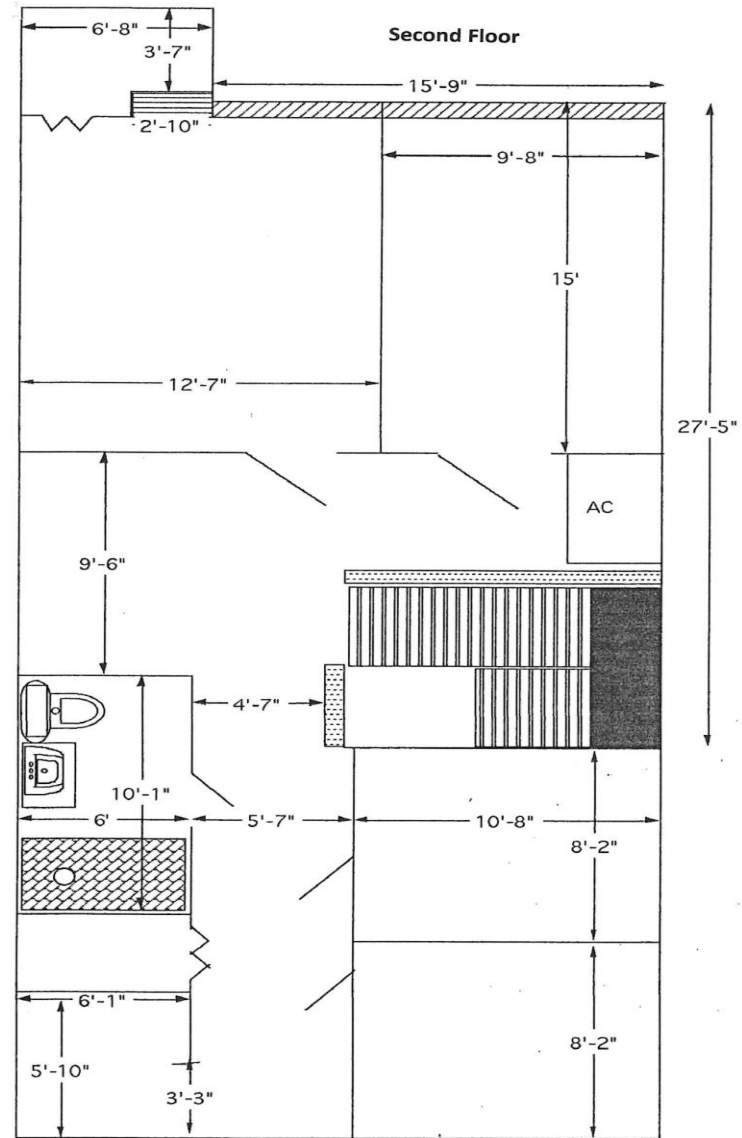
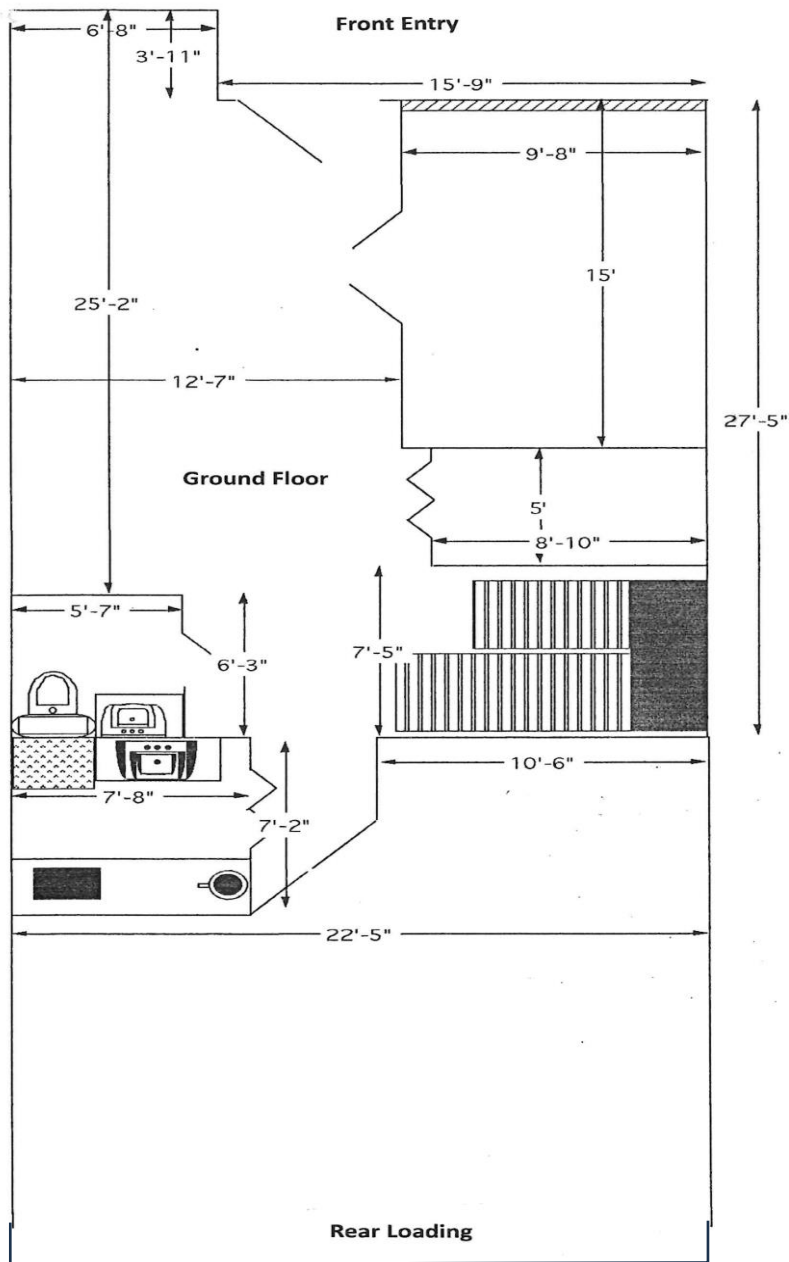

FLOOR PLANS

SUBJECT PROPERTY

BIRD ROAD
Design District



SCOTT WESTON
JOSEPH WESTON

MADDUX AND COMPANY
7250 SW 39th Terrace,
Miami, FL 33155
Office: 305.264.9661

JOSEPH WESTON
jweston@madduxco.com
305.510.2298

SCOTT WESTON
jscottweston@aol.com
786.942.6143

Bird Road

Arts and Industrial District

This exceptional office condominium association is situated in the highly sought-after Bird Road Arts & Industrial District, offering a unique blend of creative energy and industrial functionality. Nestled in the heart of Miami, FL - perfect for businesses looking to thrive in a dynamic, up-and-coming area known for its mix of art studios, galleries, and innovative companies.

Key Features:

- Modern office space with flexible layouts to suit a variety of professional needs.
- Bright, open interiors with large windows allowing ample natural light throughout the day.
- Conveniently located in an area with easy access to major highways (including US-1 and SR-826), making commuting simple for clients and employees alike.
- Surrounded by a community of artists, entrepreneurs, and industrial businesses, offering endless networking opportunities.
- The district's creative atmosphere is perfect for startups, design firms, tech companies, and other forward-thinking businesses.
- Close proximity to restaurants, cafes, and retail spaces for breaks and after-work outings.
- This office condo presents a rare opportunity to establish your business in one of Miami's most eclectic and growing areas. Whether you're an artist, a tech startup, or a professional office, this space provides the perfect environment for creativity, productivity, and success.

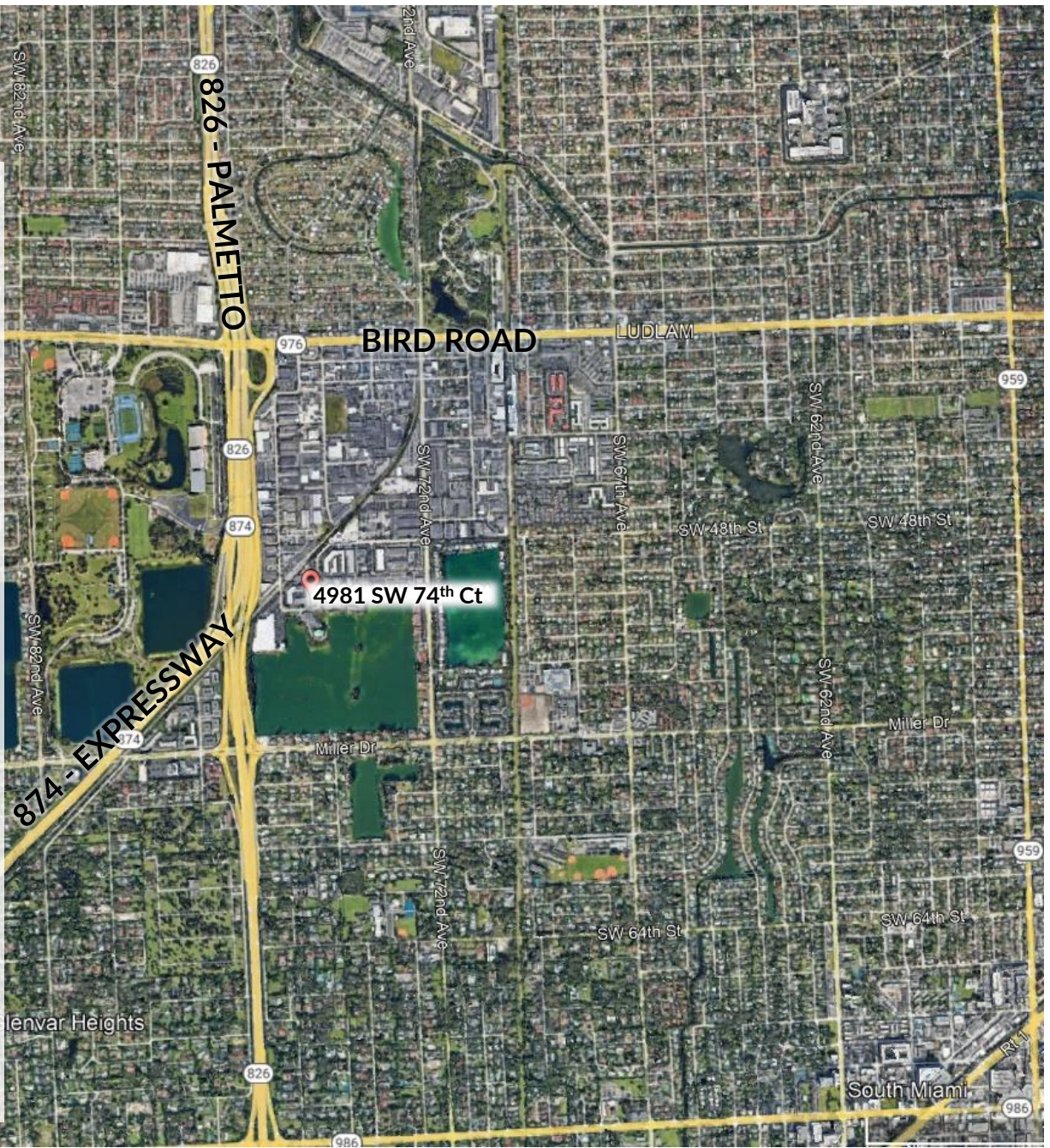

SUBJECT PROPERTY

BIRD ROAD
Design District



SCOTT WESTON
JOSEPH WESTON

MADDUX AND COMPANY
7250 SW 39th Terrace,
Miami, FL 33155
Office: 305.264.9661

JOSEPH WESTON
jweston@madduxco.com
305.510.2298

SCOTT WESTON
jscottweston@aol.com
786.942.6143

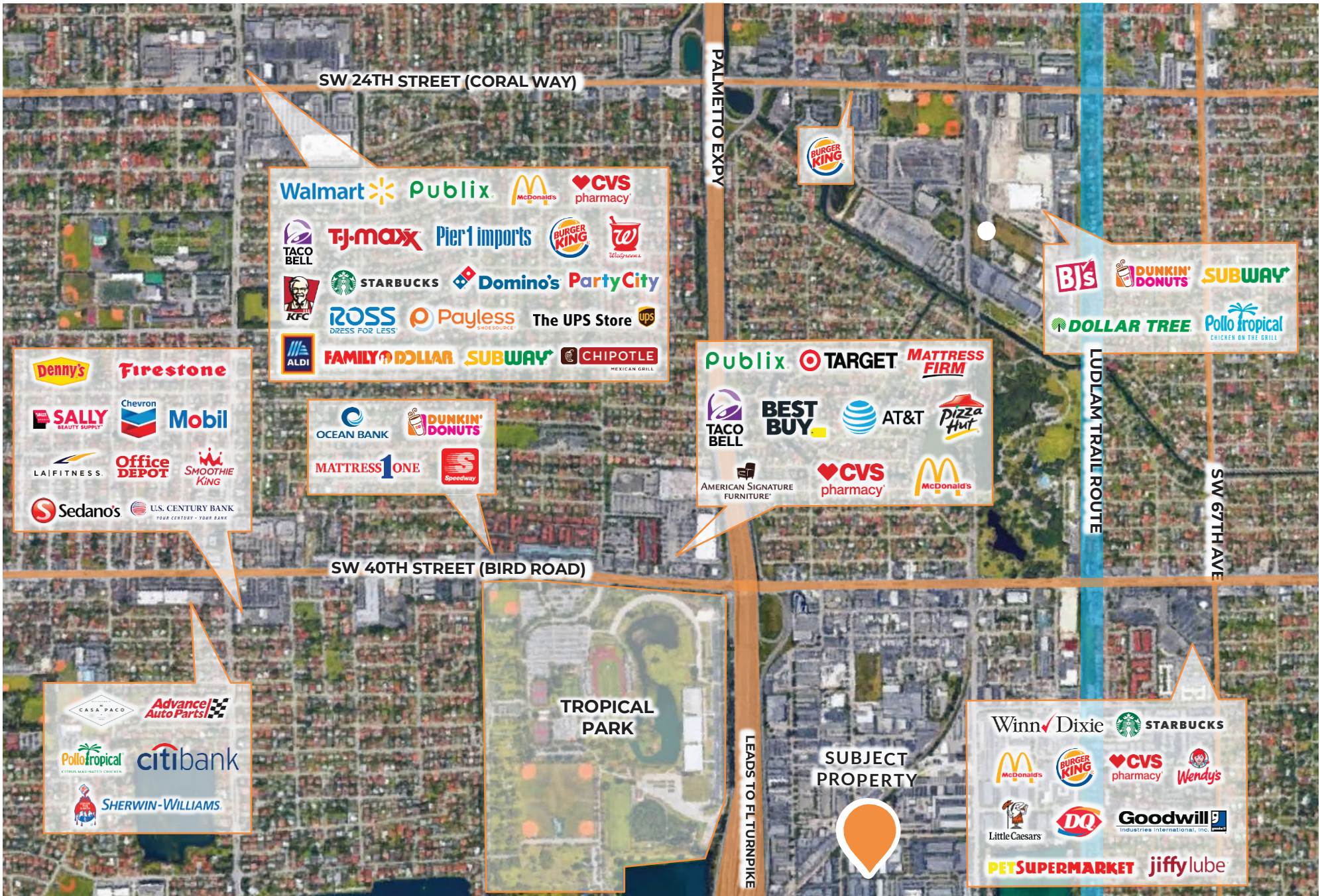

SW 24TH STREET (CORAL WAY)

PALMETTO EXPY

LUDLUM TRAIL ROUTE

SW 67TH AVE

LEADS TO FL TURNPIKE

Walmart * Publix McDonald's CVS pharmacy
 TACO BELL TJ-maxx Pier 1 imports BURGER KING Wendy's
 STARBUCKS Domino's Party City
 KFC ROSS DRESS FOR LESS Payless SHOESOURCE The UPS Store UPS
 ALDI FAMILY DOLLAR SUBWAY CHIPOTLE MEXICAN GRILL

BURGER KING

B's DUNKIN' DONUTS SUBWAY
 DOLLAR TREE Pollo Tropical CHICKEN ON THE GRILL

Denny's Firestone
 SALLY BEAUTY SUPPLY Chevron Mobil
 LAIFITNESS Office DEPOT SMOOTHIE KING
 Sedano's U.S. CENTURY BANK YOUR CENTURY - YOUR BANK

OCEAN BANK DUNKIN' DONUTS
 MATTRESS 1 ONE Speedway

Publix TARGET MATTRESS FIRM
 TACO BELL BEST BUY AT&T Pizza Hut
 AMERICAN SIGNATURE FURNITURE CVS pharmacy McDonald's

SW 40TH STREET (BIRD ROAD)



TROPICAL PARK

SUBJECT PROPERTY



CASA PACO Advance! Auto Parts!
 Pollo Tropical CITIBANK
 SHERWIN-WILLIAMS

Winn-Dixie STARBUCKS
 McDonald's BURGER KING CVS pharmacy Wendy's
 Little Caesars DQ Goodwill INDUSTRIES INTERNATIONAL, INC.
 PET SUPERMARKET jiffylube

SUBJECT PROPERTY

BIRD ROAD Design District



SCOTT WESTON
 JOSEPH WESTON

MADDUX AND COMPANY
 7250 SW 39th Terrace,
 Miami, FL 33155
 Office: 305.264.9661

JOSEPH WESTON
jweston@maddux.com
 305.510.2298

SCOTT WESTON
jscottweston@aol.com
 786.942.6143