

3655

W Quail Avenue



FOR LEASE



Ali Roesener
NRE:S.0172338
Senior Vice President
(702) 765-8894

ali@gatskicommercial.com

Tony Alvarez
NRE:S.0200369
Associate
(702) 765-8880

tony@gatskicommercial.com



3655 W QUAIL AVENUE

LOCATION OVERVIEW

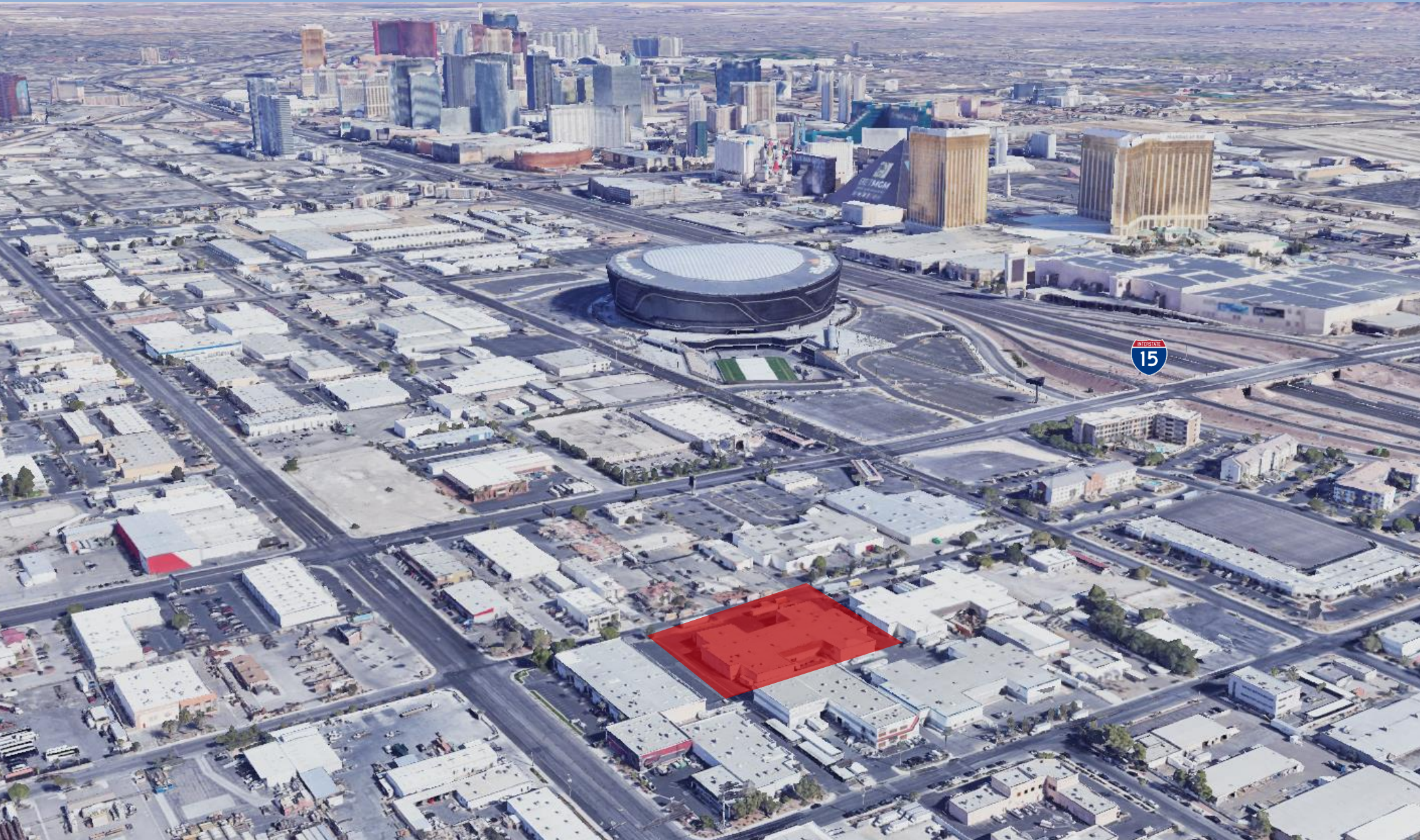

Ali Roesener
NRE:S.0172338
Senior Vice President
(702) 765-8894

Tony Alvarez
NRE:S.0200369
Associate
(702) 765-8880

ali@gatskicommercial.com tony@gatskicommercial.com



3655 W QUAIL AVENUE

AVAILABILITY

SUITE	TOTAL SF	OFFICE SF	WAREHOUSE SF	DOCK	GRADE	RATE	CAM	MONTHLY TOTAL
D	7,054	3,527	3,527	1	1	\$1.25	\$0.20	\$10,228.30

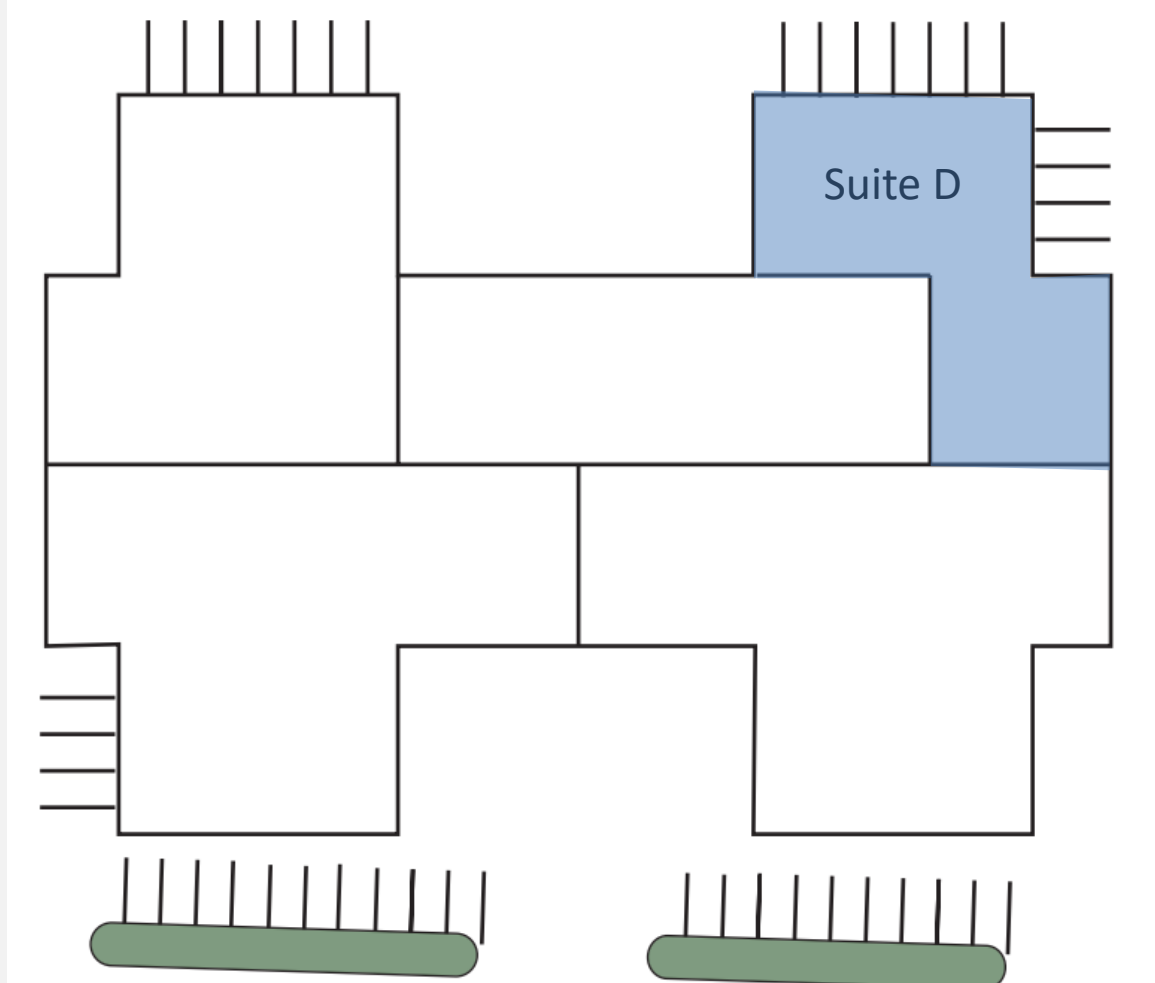

Ali Roesener
NRE:S.0172338
Senior Vice President
(702) 765-8894

ali@gatskicommercial.com

Tony Alvarez
NRE:S.0200369
Associate
(702) 765-8880

tony@gatskicommercial.com



Property Highlights

- 3655 W Quail Ave Unit D
- 7,054 SF Unit
 - +/-3,527 SF Office
 - +/-3,527 SF Warehouse
- 1 Dock Doors
 - 12' x 14'
- 1 Grade Door
 - 16' x 12'
- Side Ramp up to Dock Doors
- Clear Height 21'
- Fully Sprinklered
- 3 Phase Power 208/120 amp
- Close Proximity to I-15 and I-215 Freeway

Lease Rate: \$1.25/SF

NNN: \$0.20/SF

