

1280 Boulevard Way

925-899-9457



First Class Suites available in Walnut Creek

Welcome to our building, located minutes from downtown Walnut Creek and 680/24 freeway access. We go above and beyond to ensure our tenants and their guests have a wonderful experience here with plenty of parking and multiple seating areas that offer colorful landscaping and quiet ambience near our peaceful fountain. The building is equipped with security cameras for the safety of our tenants and their clients. There is a wide variety of tenants that call this home.



★ *Move - In Specials available* ★

450 – 875 Sq. Ft. available and ready to move in

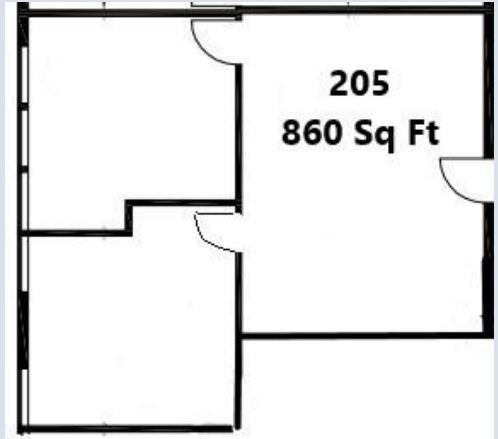
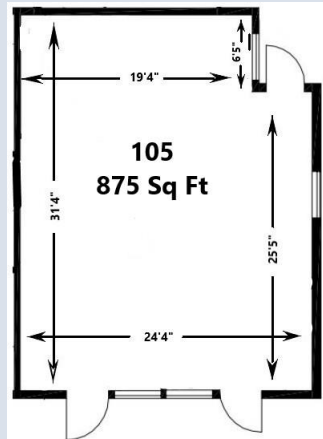
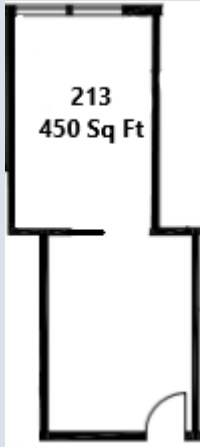

Highlights and Amenities

- 24/7 Access to building and Parking (with security code after hours)
- Abundant parking – enough space for company vehicles and guests
- Well maintained and fully stocked restrooms on every floor
- Janitorial Service – 5 days a week in every suite
- Onsite Management
- Security cameras
- Pet Friendly
- Flexible lease terms
- Easy access to 680/24 Freeway
- Minutes to downtown Walnut Creek and Lafayette
- All utilities – available 24/7
- Zoned HVAC
- Beautiful landscaping and seating area
- Convenience store right next door
- Steps from Morucci's – The best sandwich shop in town



Proudly owned and operated by Sherman Properties with building locations in Walnut Creek and Danville.

*1280 Boulevard Way
Walnut Creek, CA 94595*

*1800 Tice Valley Blvd
Walnut Creek, CA 94597*

*822 Hartz Way
Danville, CA 94526*

*588 San Ramon Valley Blvd
Danville, CA 94526*

Call Ryan @ 925-899-9457 for details

