



PACIFIC
GUARDIAN
CENTER



Floor Plans



Makai Tower Floor Plans



Suite 170 - 1,090 SF

733 Bishop Street, Makai Tower

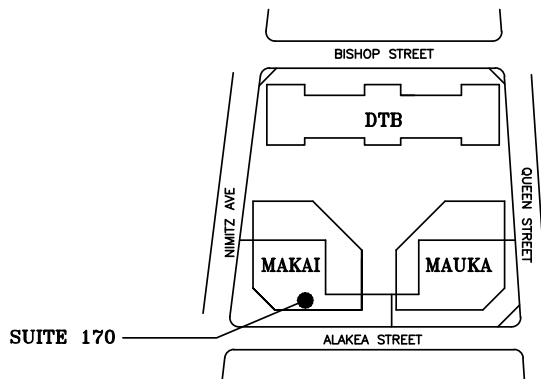
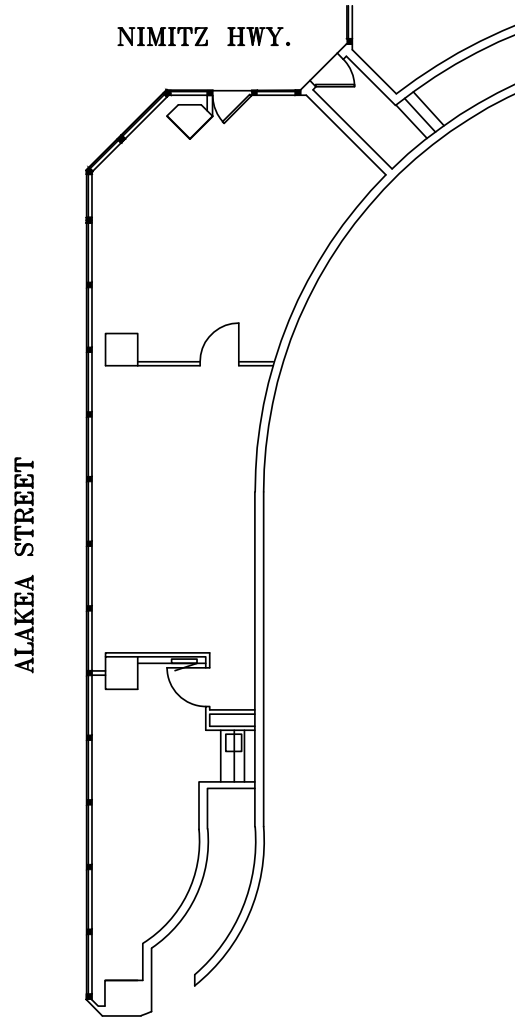

SCALE: N.T.S.

**MAKAI TOWER
SUITE 170**

**901 Useable sq. ft.
1,090 Rentable sq. ft.**

Suite 181 - 1,717 SF

733 Bishop Street, Makai Tower

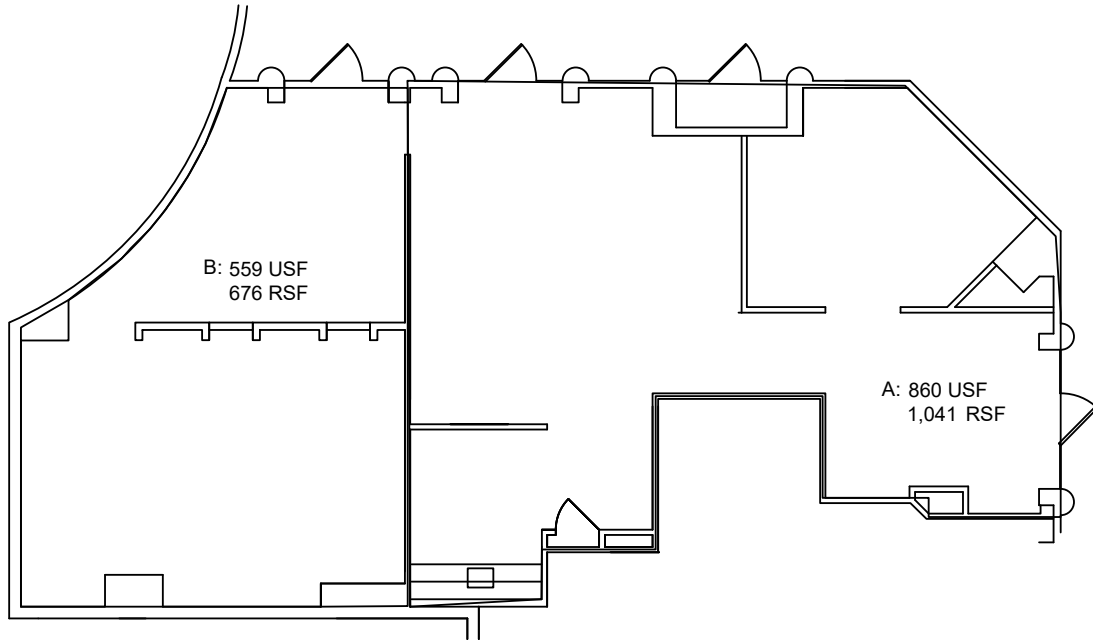

SCALE: 3/32" = 1'=0"

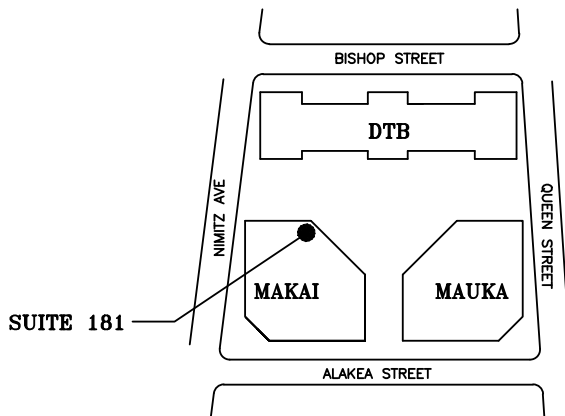

MAKAI TOWER
SUITE 181

1,419 USF
1,717 RSF

Suite 1101 - 631 SF

733 Bishop Street, Makai Tower

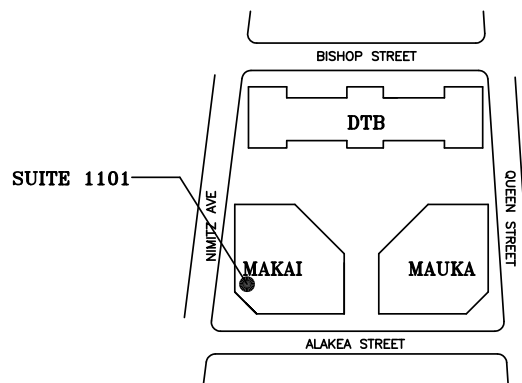
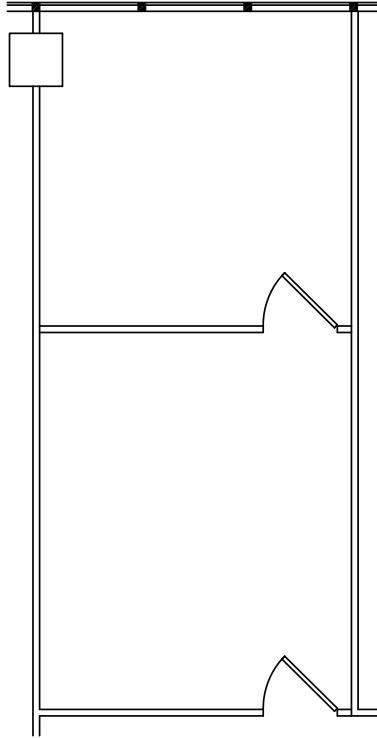

SCALE: 1/4" = 1'-0"

MAKAI TOWER
SUITE 1101

522 Useable sq. ft.
631 Rentable sq. ft.

Suite 1170 - 1,244 SF

733 Bishop Street, Makai Tower

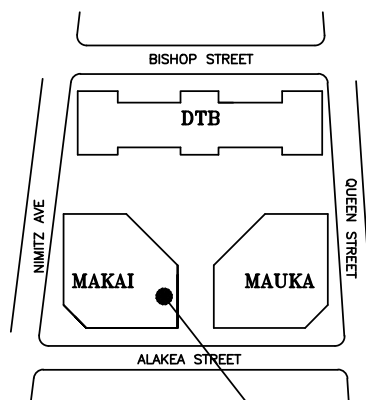
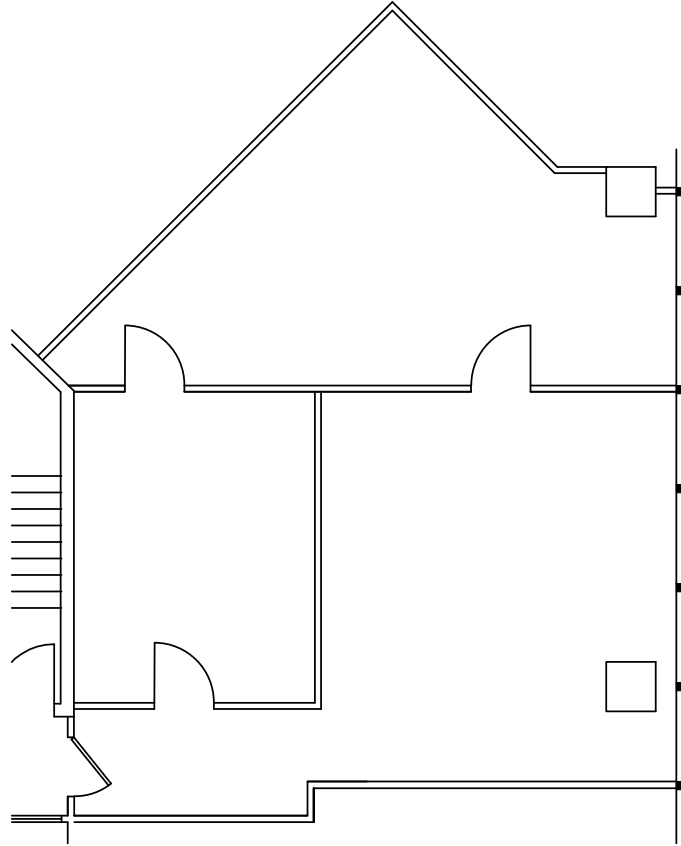

SCALE: NOT TO SCALE

MAKAI TOWER
SUITE 1170

1,028 Useable sq. ft.
1,244 Rentable sq. ft.

SUITE 1170

Suite 1430 - 2,834 SF

733 Bishop Street, Makai Tower

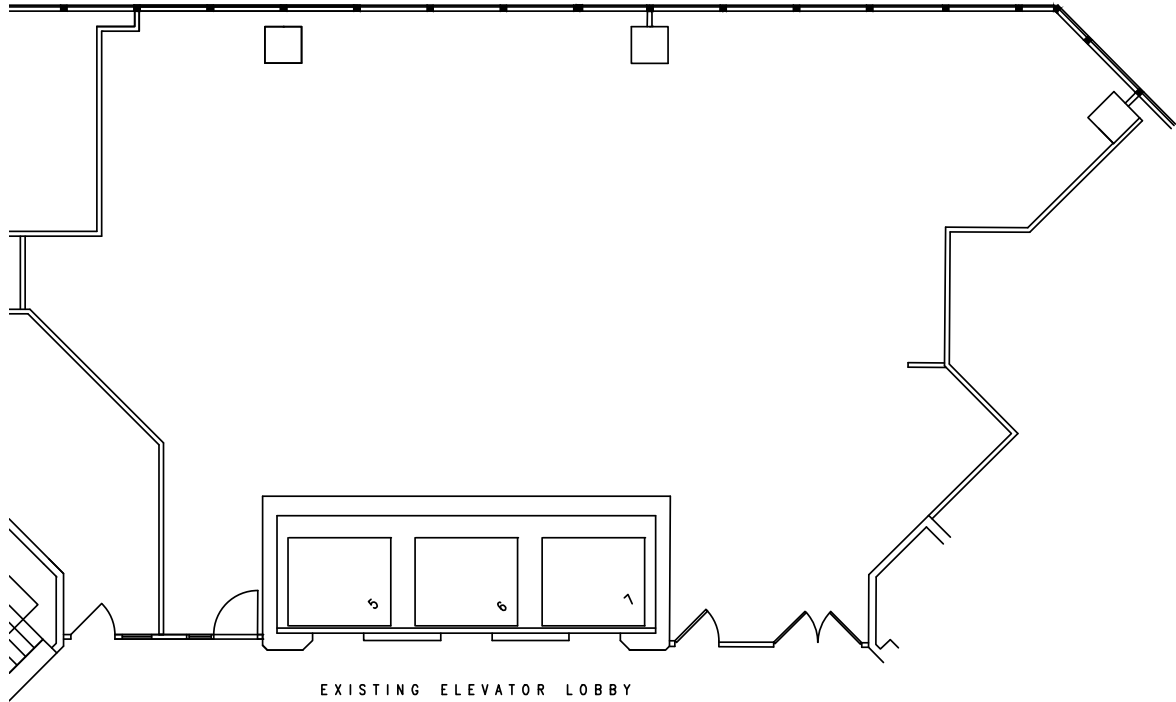

SCALE: 1/16" = 1'-0"

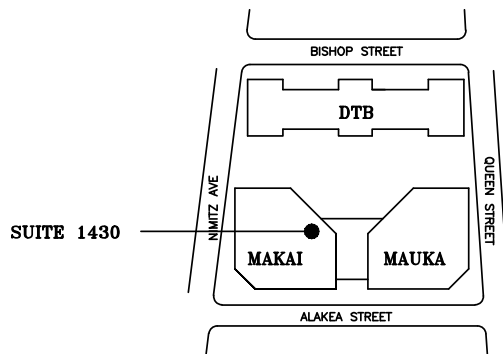

**MAKAI TOWER
SUITE 1430**

**2,342 USABLE SQ. FT.
2,834 RENTABLE SQ. FT.**

Suite 1520 - 1,549 SF

733 Bishop Street, Makai Tower

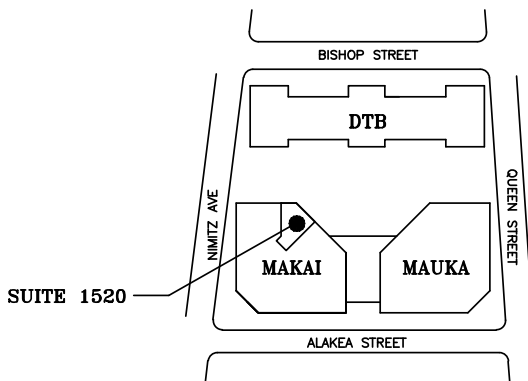
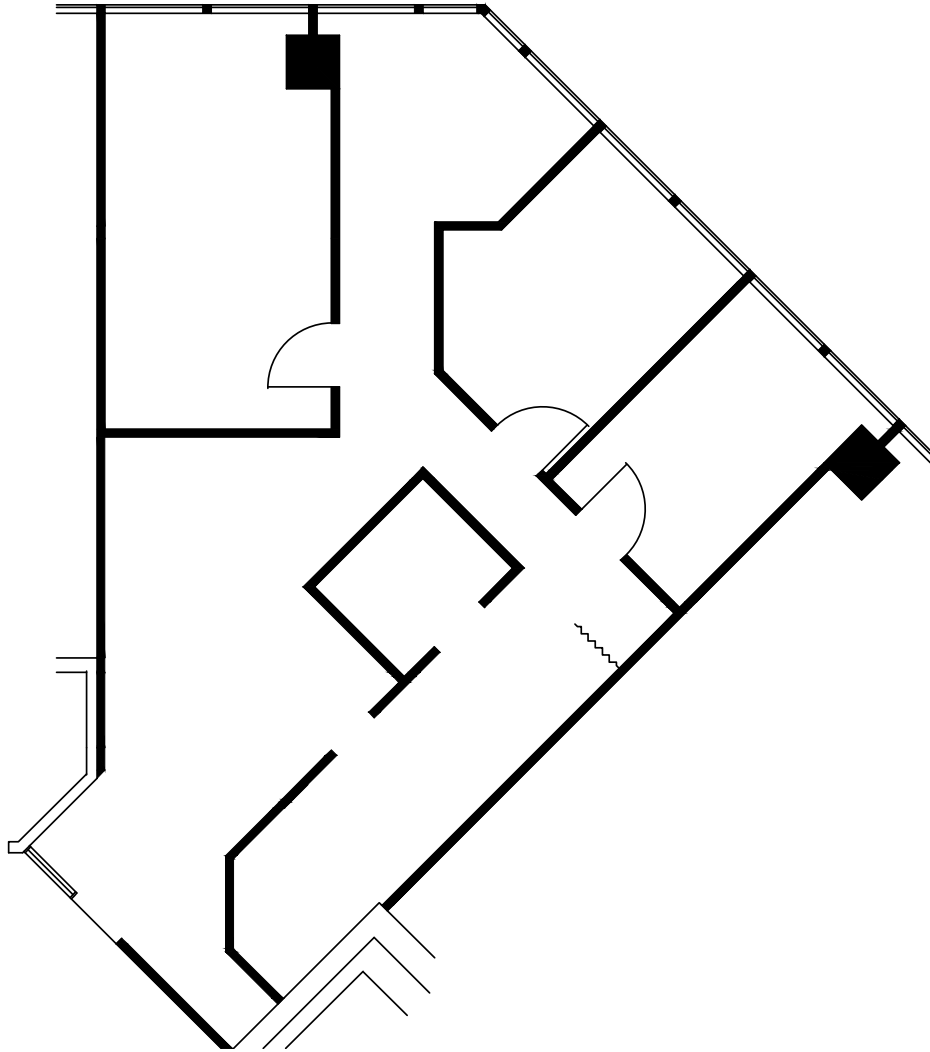

SCALE: 1/8"=1'-0"

MAKAI TOWER
SUITE 1520

1,280 Useable sq. ft.
1,549 Rentable sq. ft.

Suite 1565 - 863 SF

733 Bishop Street, Makai Tower

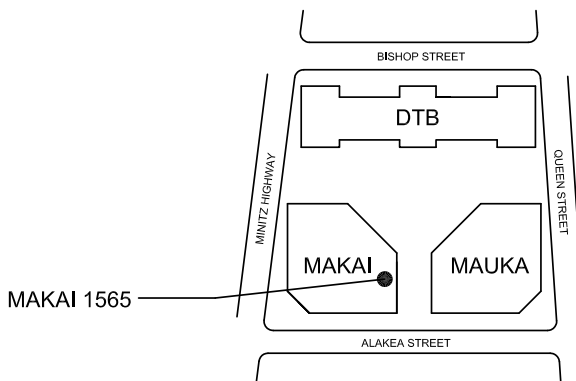
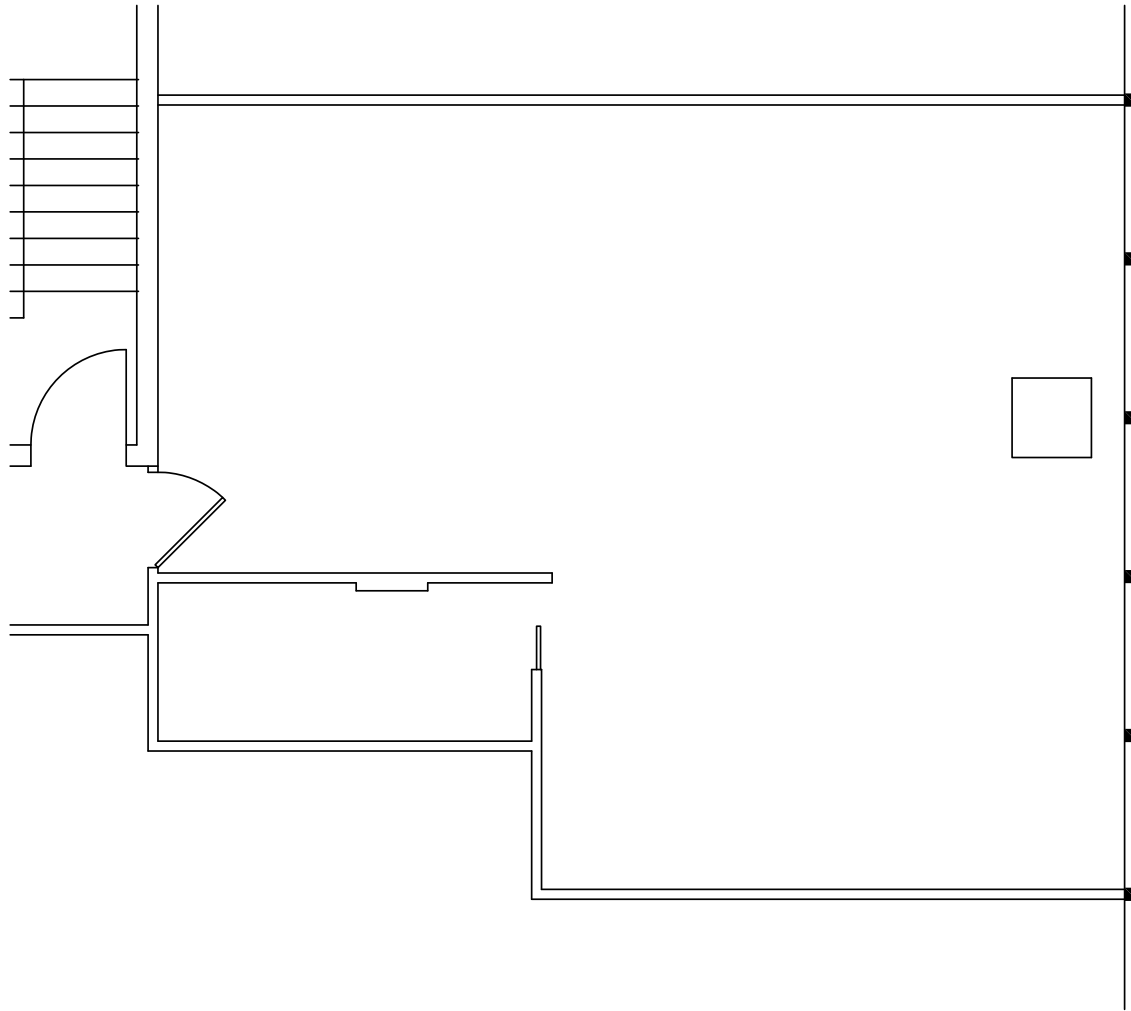

SCALE: NOT TO SCALE

**MAKAI TOWER
SUITE 1565**

**713 USEABLE SQ. FT.
863 RENTABLE SQ. FT.**

Suite 1750 - 3,695 SF

733 Bishop Street, Makai Tower

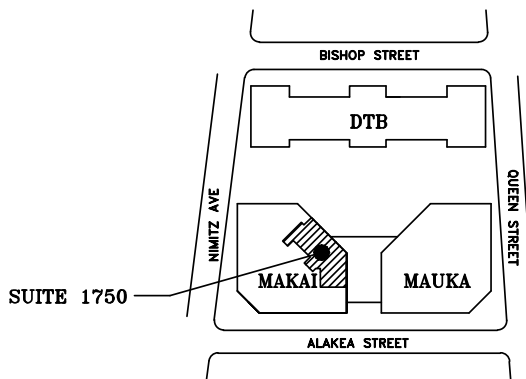
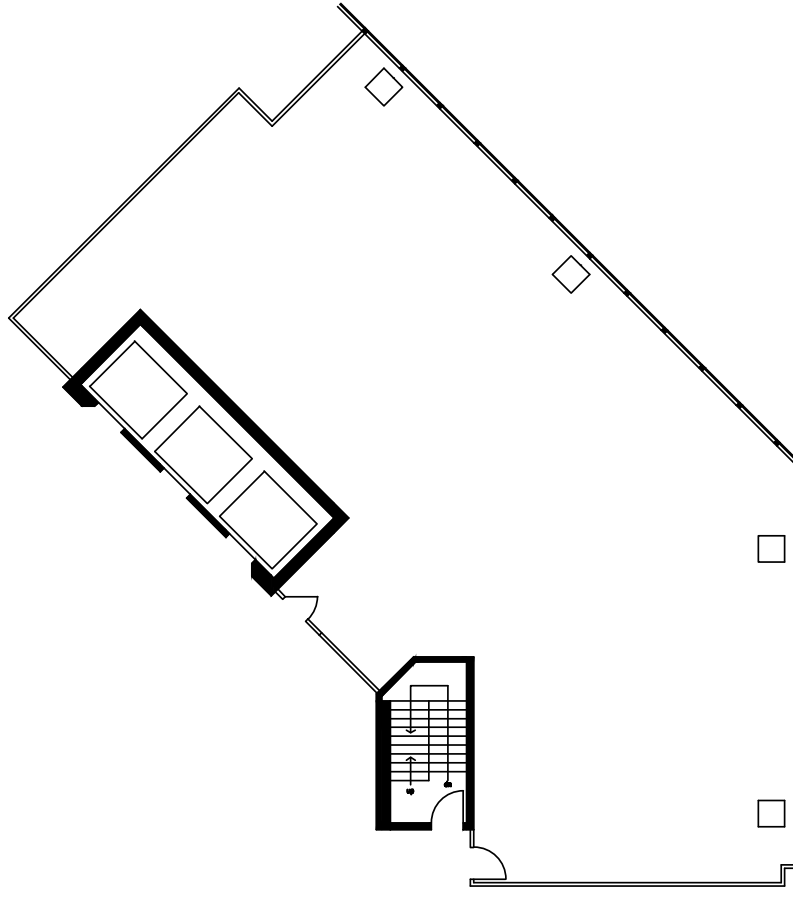

SCALE: 1/16" = 1'

MAKAI TOWER
SUITE 1750

3,054 Useable sq. ft.
3,695 Rentable sq. ft.

Suite 2160 - 1,223 SF

733 Bishop Street, Makai Tower

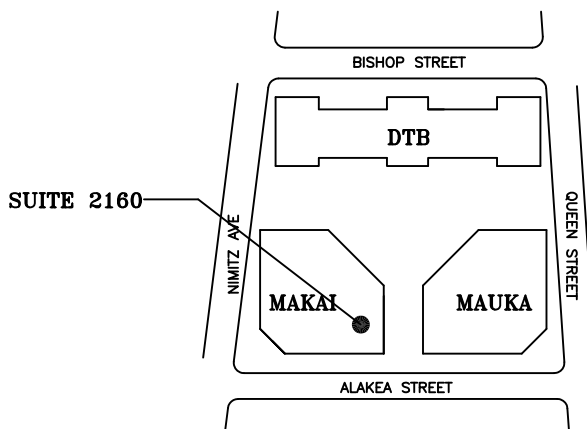
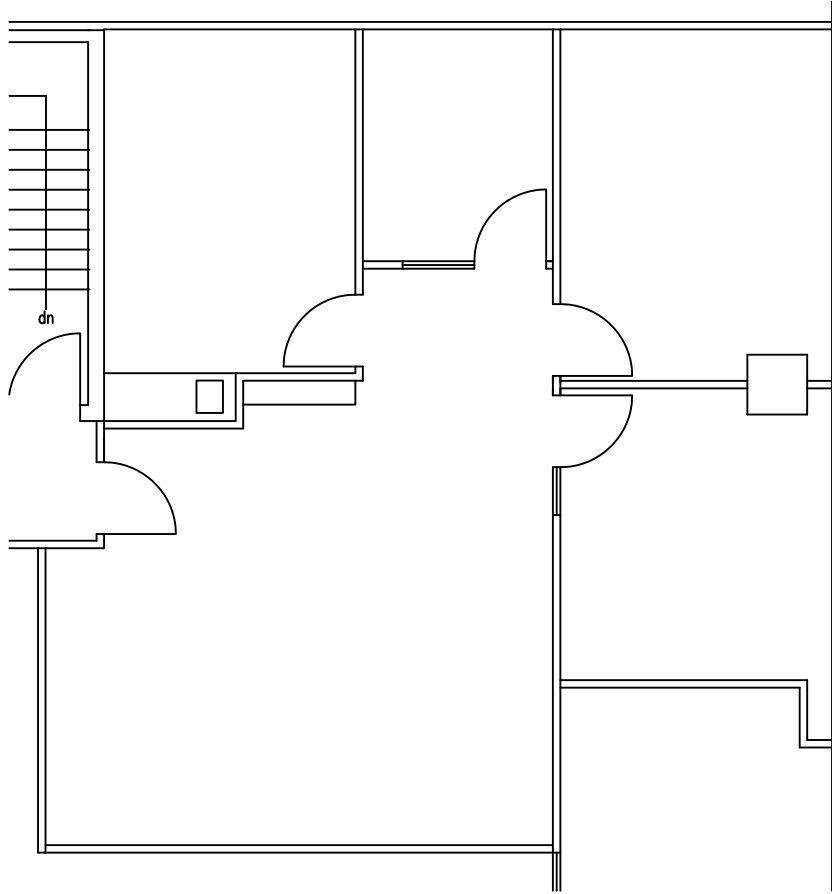

SCALE: 1/8" = 1'-0"

MAKAI TOWER
SUITE 2160

1,011 Useable sq. ft.
1,223 Rentable sq. ft.

Suite 2300 - 1,496 SF

733 Bishop Street, Makai Tower



View Virtual Tour

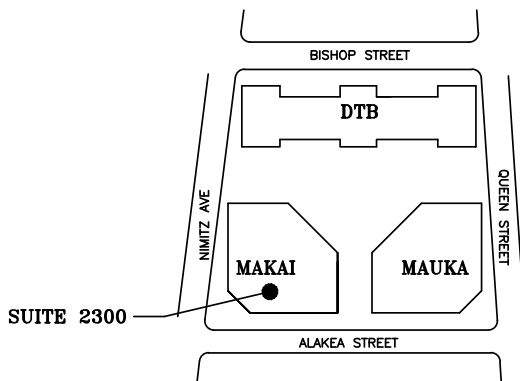
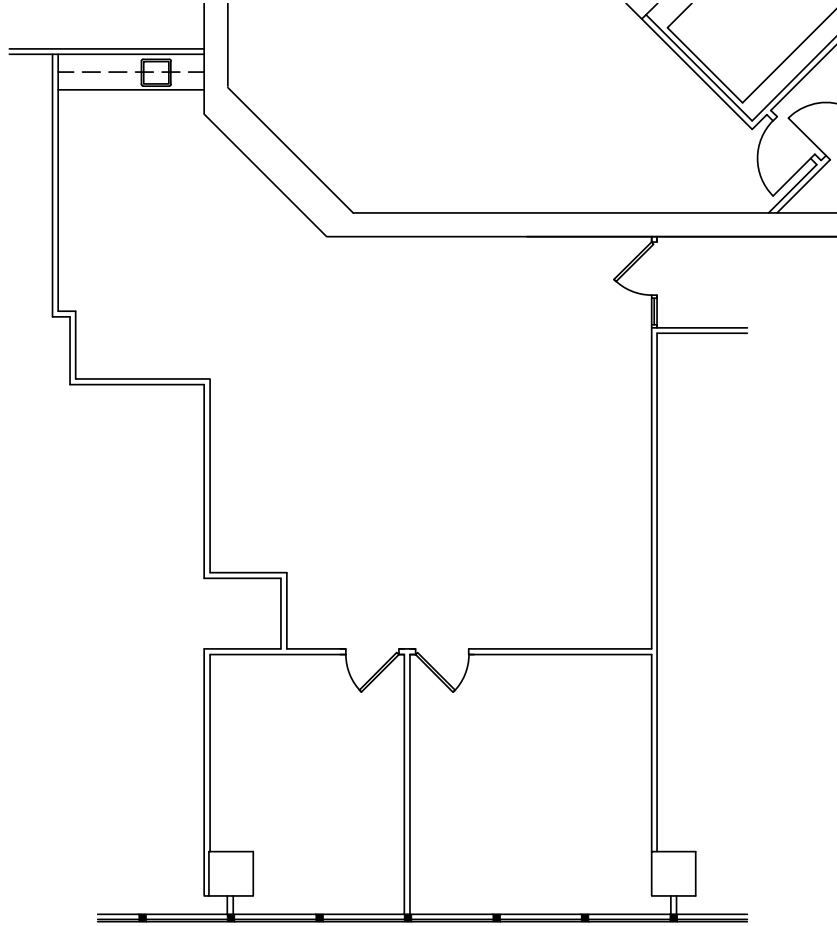

SCALE: NTS

MAKAI TOWER
SUITE 2300

1,236 Useable sq. ft.
1,496 Rentable sq. ft.

Suite 2390 - 1,464 SF

733 Bishop Street, Makai Tower

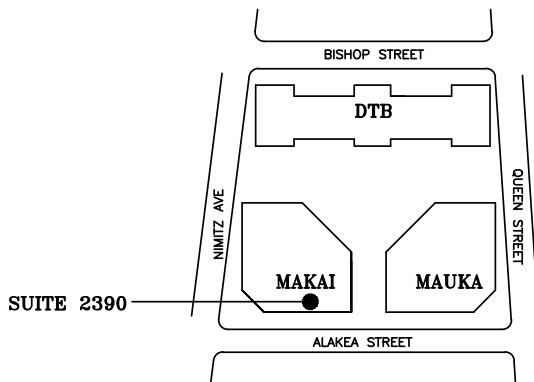
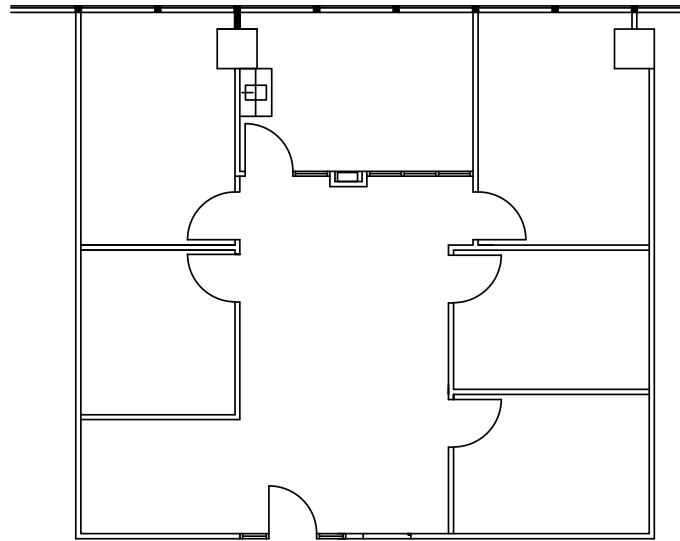

0 2' 5' 10' 20'

Scale: 3/32" = 1'

MAKAI TOWER
SUITE 2390

1,210 Useable sq. ft.
1,464 Rentable sq. ft.

Suite 2400 - 14,994 SF

733 Bishop Street, Makai Tower

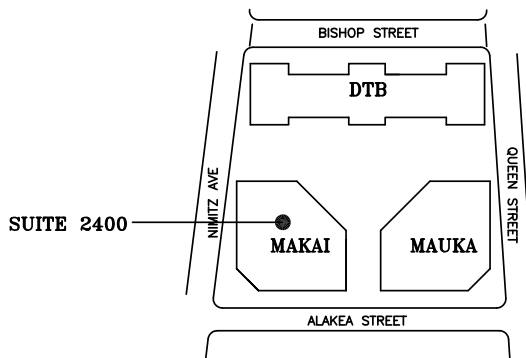
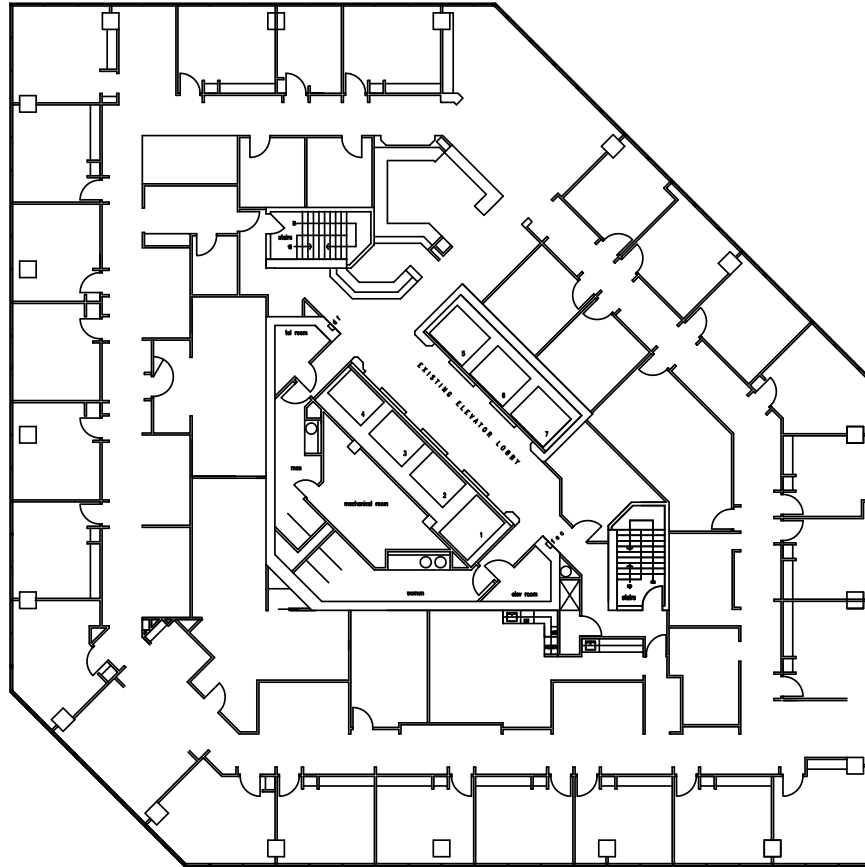

**MAKAI TOWER
SUITE 2400**

**13,315 Useable sq. ft.
14,994 Rentable sq. ft.**

Suite 2555 - 1,042 SF

733 Bishop Street, Makai Tower

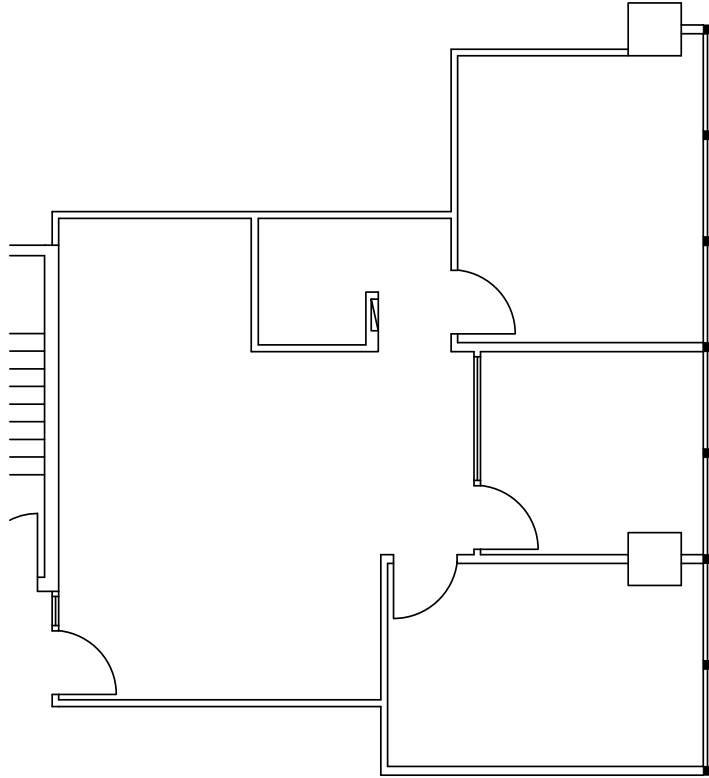

0 1' 5' 10'
SCALE: 1/8"=1'-0"

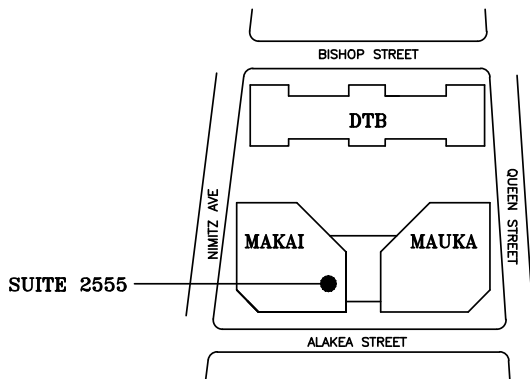

**MAKAI TOWER
SUITE 2555**

**861 Useable sq. ft.
1,042 Rentable sq. ft.**

Suite 2560 - 1,342 SF

733 Bishop Street, Makai Tower

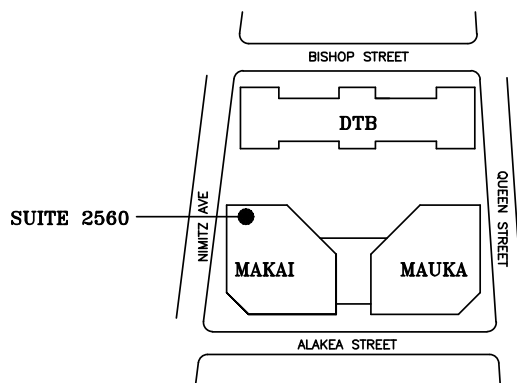
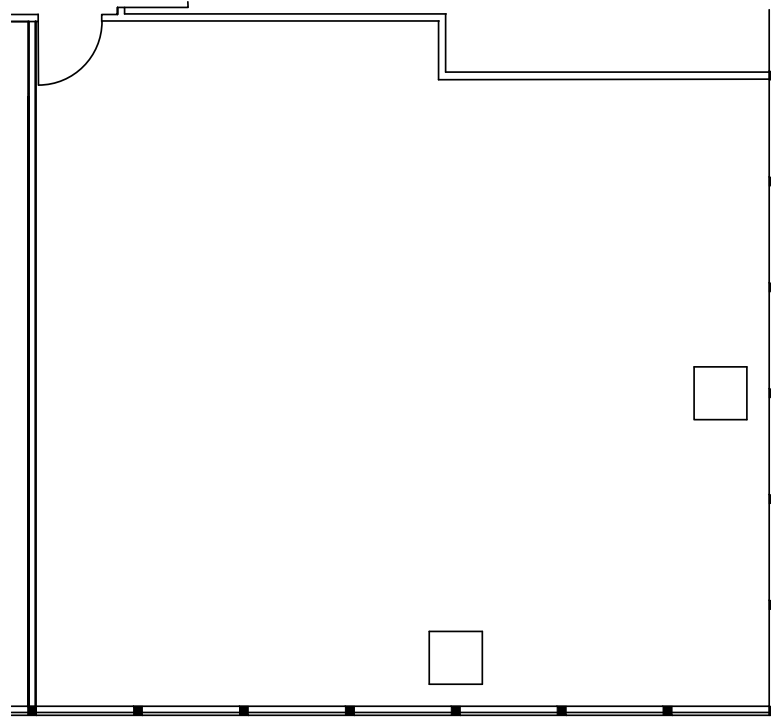

SCALE: 1/8" = 1'-0"

**MAKAI TOWER
SUITE 2560**

1,109 Usable sq. ft.
1,342 Rentable sq. ft.

Suite 2950 - 3,597 SF

733 Bishop Street, Makai Tower

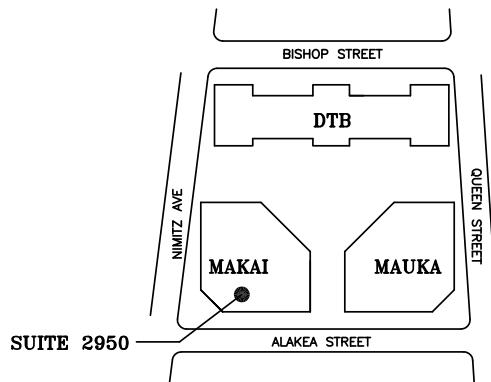
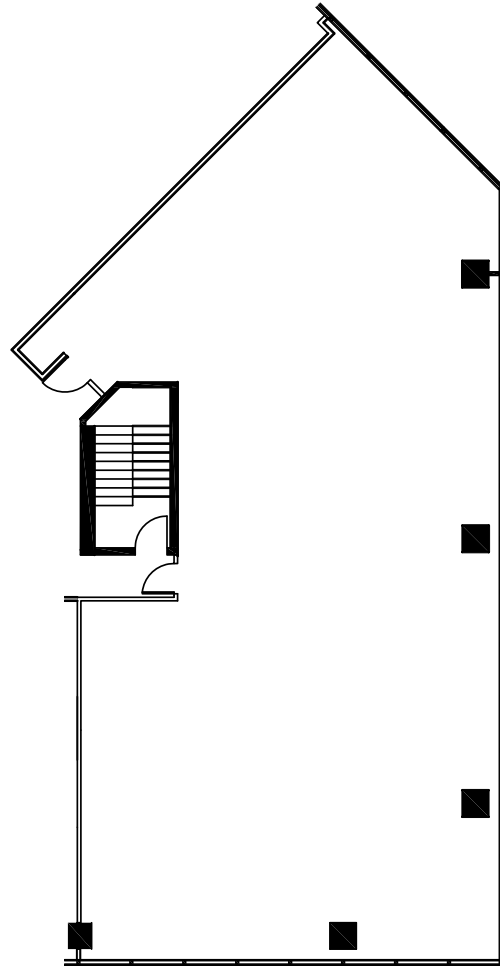

SCALE: 1/16" = 1'-0"

**MAKAI TOWER
SUITE 2950**

2,973 Useable Sq. Ft.
3,597 Rentable Sq. Ft.

Mauka Tower Floor Plans



Suite 116 - 2,725 SF

737 Bishop Street, Mauka Tower

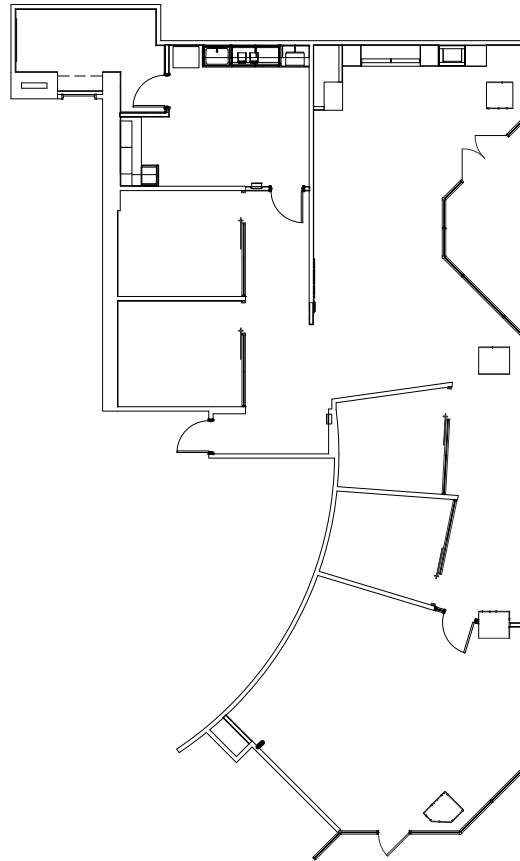

SCALE: 1/16" = 1'-0"

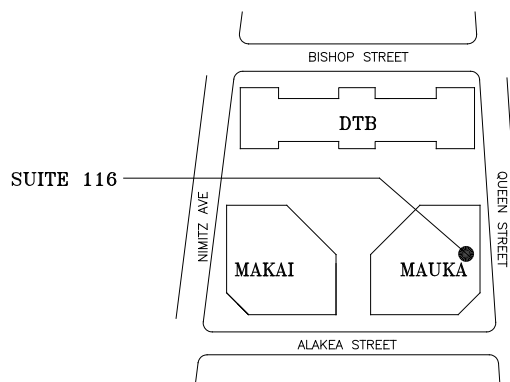

MAUKA TOWER
SUITE 116

2,252 Useable sq. ft.
2,725 Rentable sq. ft.

Suite 149 - 2,575 SF

737 Bishop Street, Mauka Tower

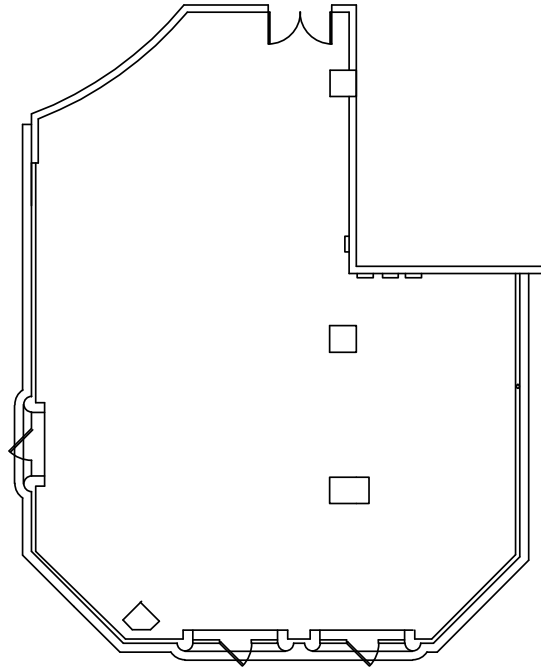

SCALE: 1/16"=1'-0"
0' 5' 10'

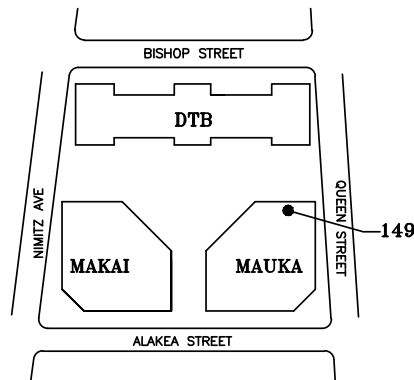

MAUKA TOWER
SUITE 149

2,128 Useable sq. ft.
2,575 Rentable sq. ft.

Suite 1100 - 14,719 SF

737 Bishop Street, Mauka Tower

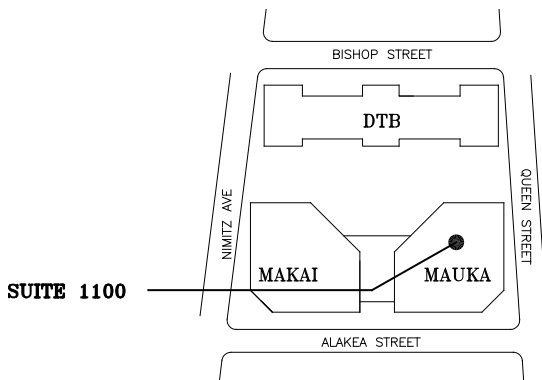
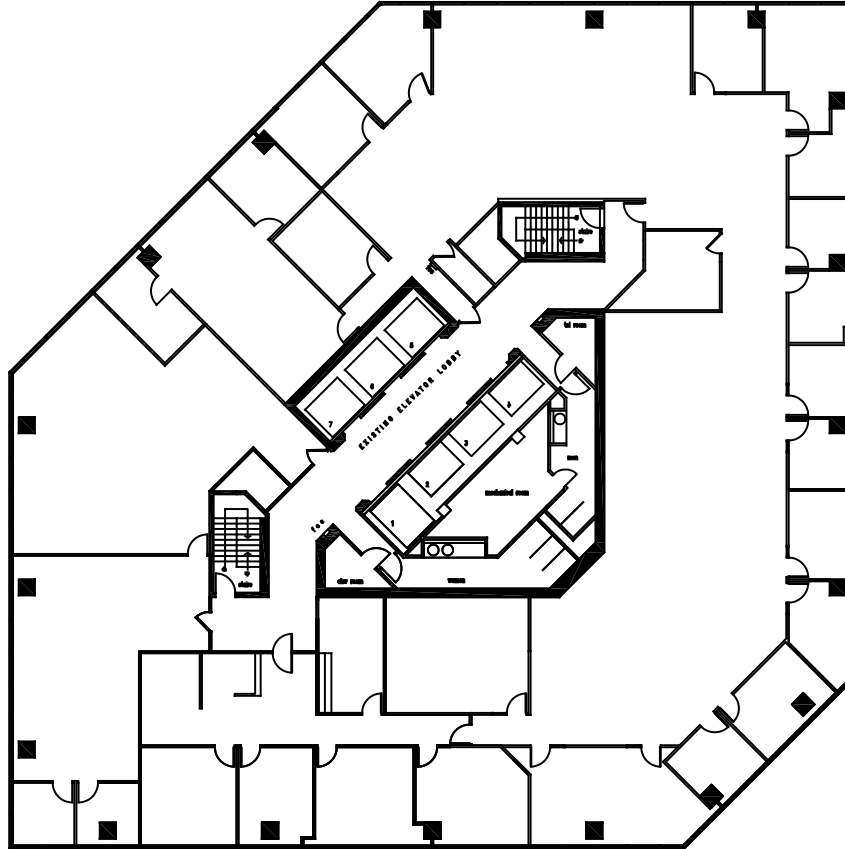

SCALE: N.T.S.

**MAUKA TOWER
SUITE 1100**

**13,161 USABLE SQ. FT.
14,719 RENTABLE SQ. FT.**

Suite 1200 - 14,573 SF

737 Bishop Street, Mauka Tower

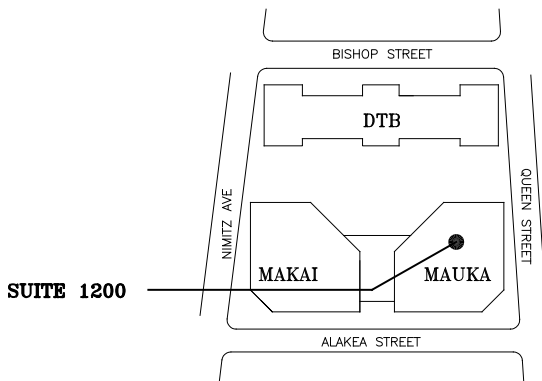
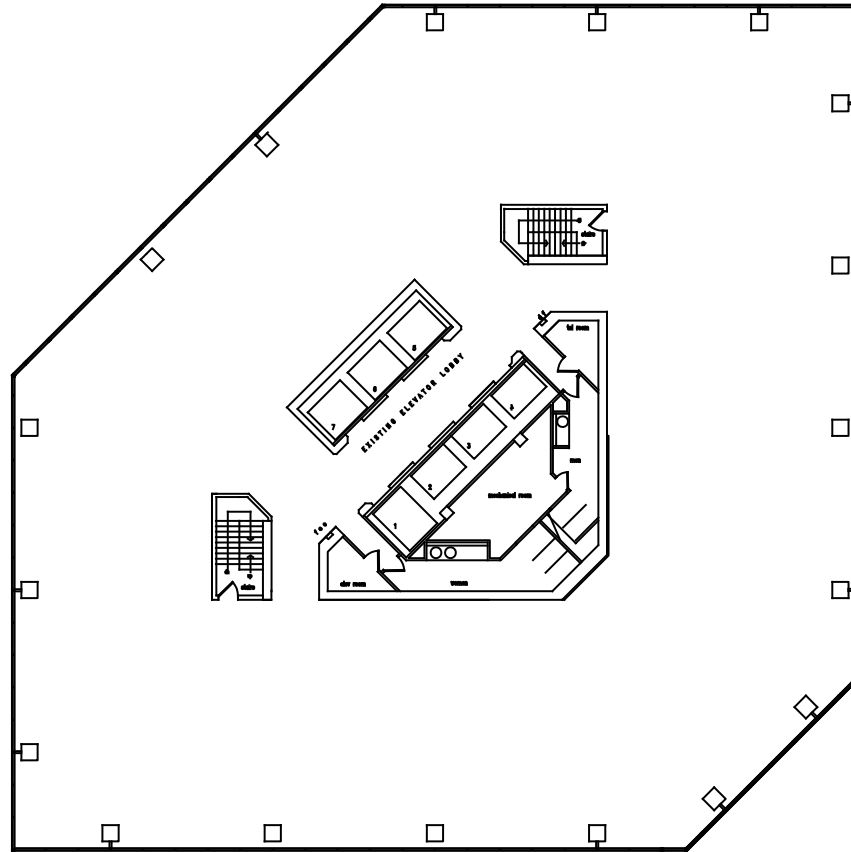

SCALE: N.T.S.

**MAUKA TOWER
SUITE 1200**

**13,282 USABLE SQ. FT.
14,573 RENTABLE SQ. FT.**

Suite 1400 - 3,479 SF

737 Bishop Street, Mauka Tower

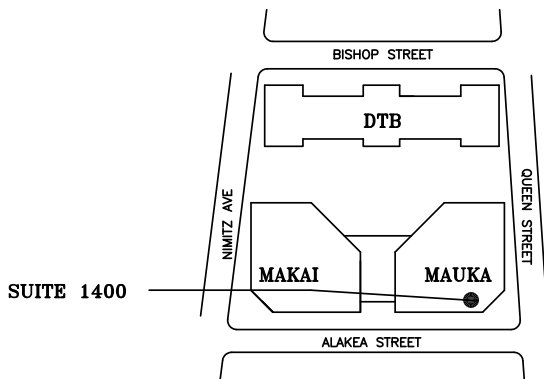
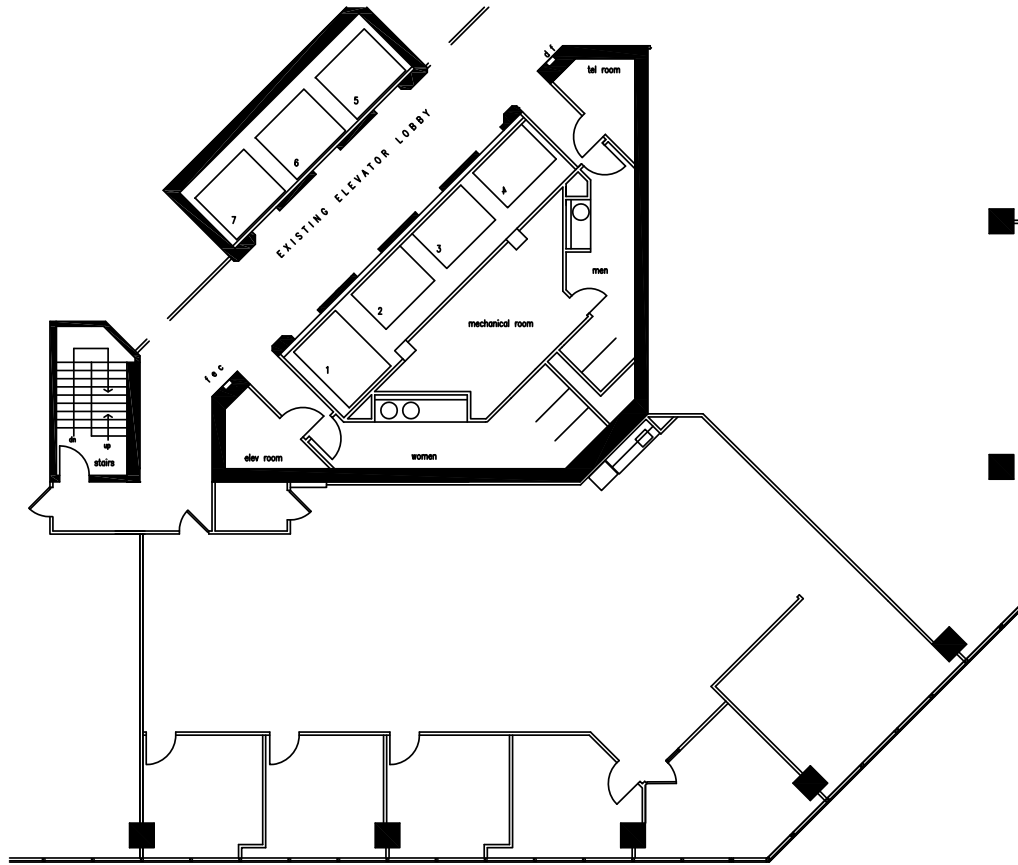

SCALE: N.T.S.

**MAUKA TOWER
SUITE 1400**

**2,875 USABLE SQ. FT.
3,479 RENTABLE SQ. FT.**

Suite 1420 - 1,685 SF

737 Bishop Street, Mauka Tower

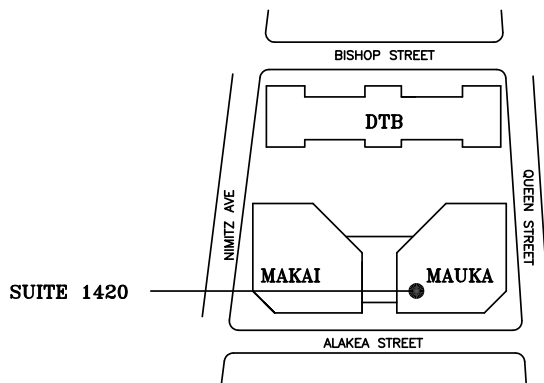
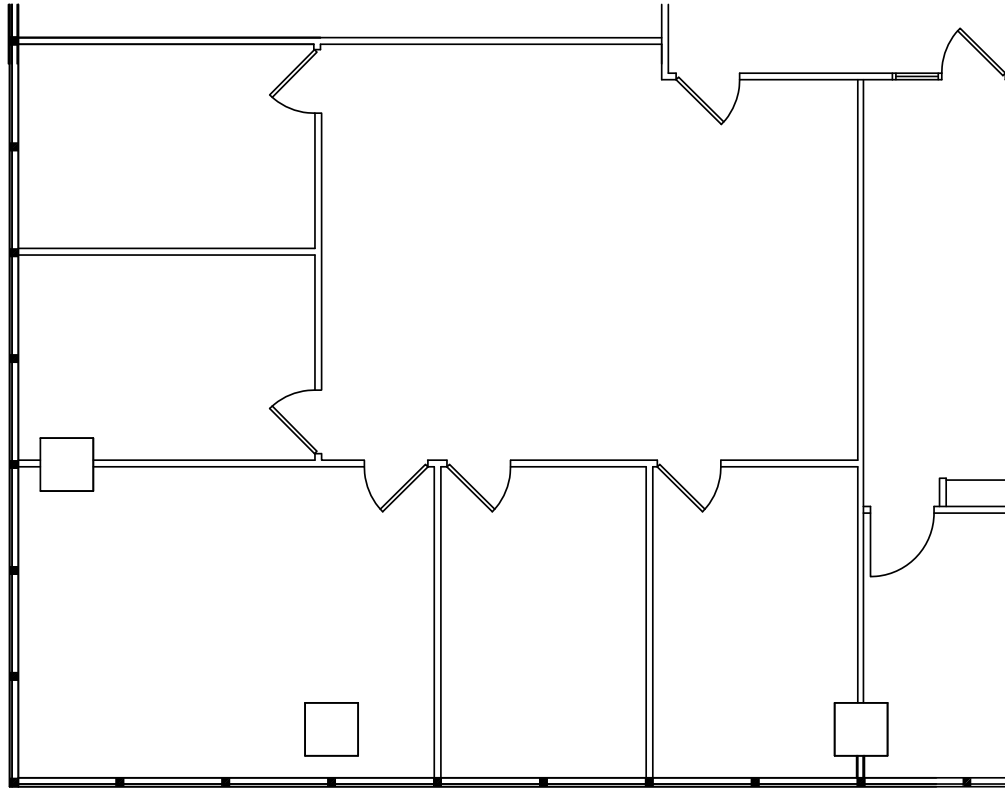

SCALE: N.T.S.

MAUKA TOWER
SUITE 1420

1,393 USF
1,685 RSF

Suite 1430 - 2,761 SF

737 Bishop Street, Mauka Tower

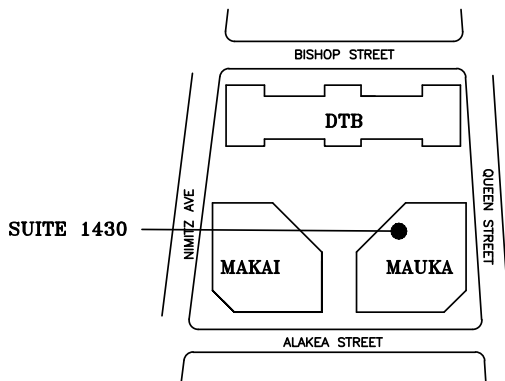
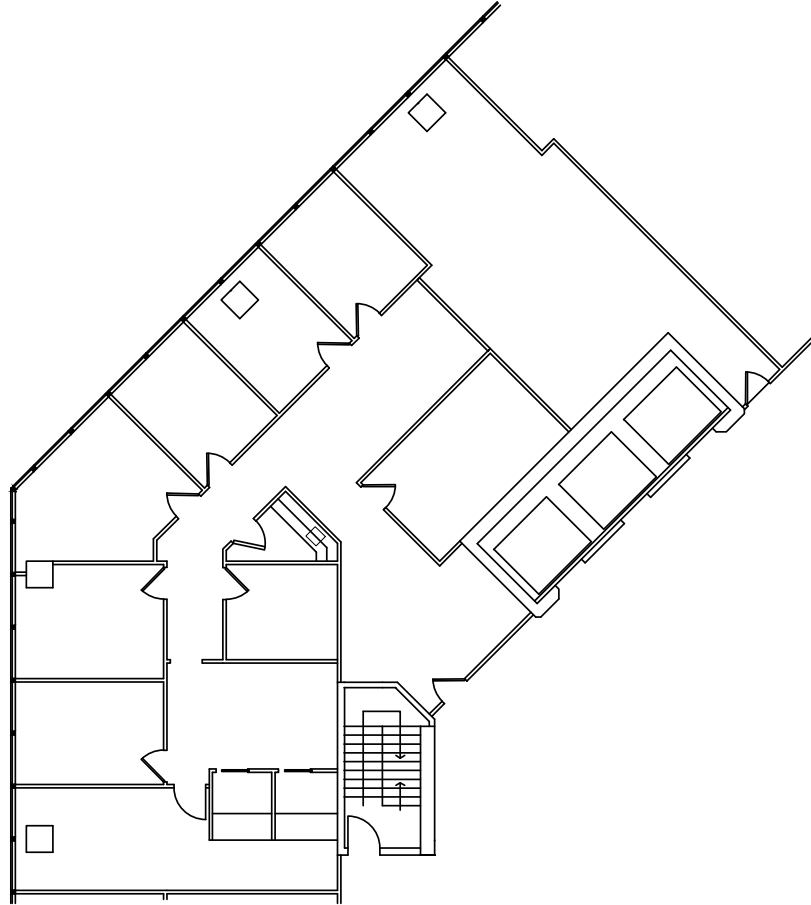

SCALE: N.T.S.

MAUKA TOWER
SUITE 1430

2,282 Useable sq. ft.
2,761 Rentable sq. ft.

Suite 1480 - 2,670 SF

737 Bishop Street, Mauka Tower

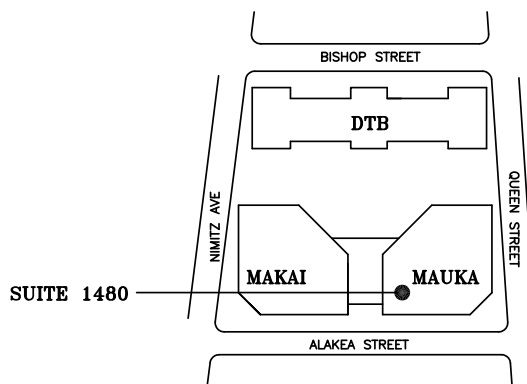
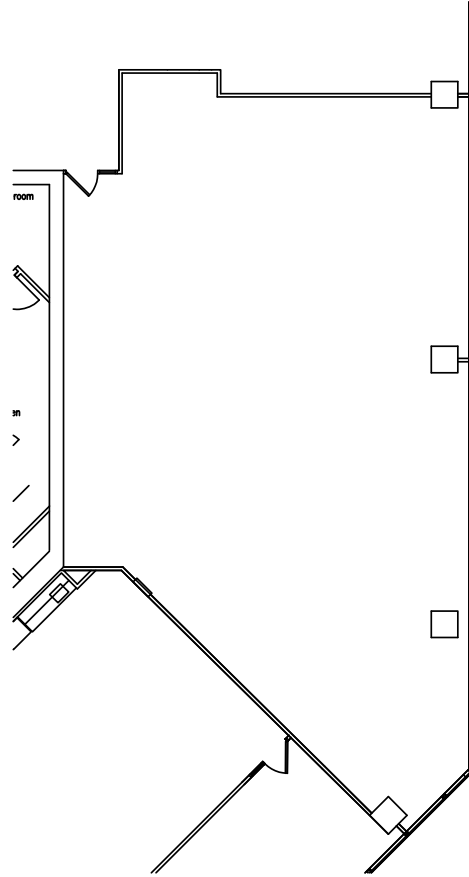

SCALE: 1/16" = 1'-0"

MAUKA TOWER
SUITE 1480

2,206 USF
2,670 RSF

Suite 1655 - 2,756 SF

737 Bishop Street, Mauka Tower

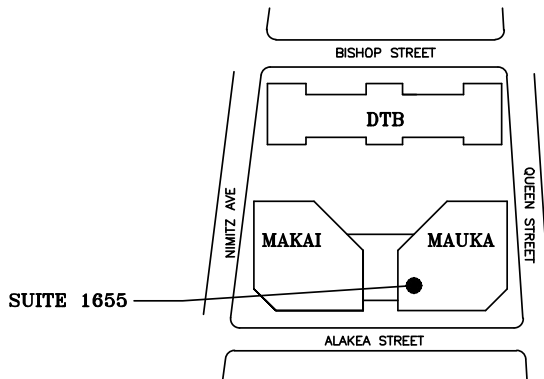
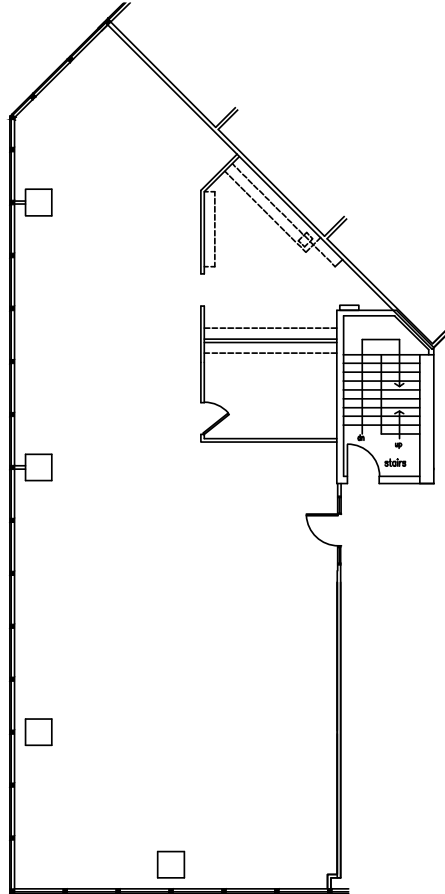

SCALE: 1/16" = 1'

MAUKA TOWER
SUITE 1655

2,278 Useable sq. ft.
2,756 Rentable sq. ft.

Suite 1800 - 2,070 SF

737 Bishop Street, Mauka Tower

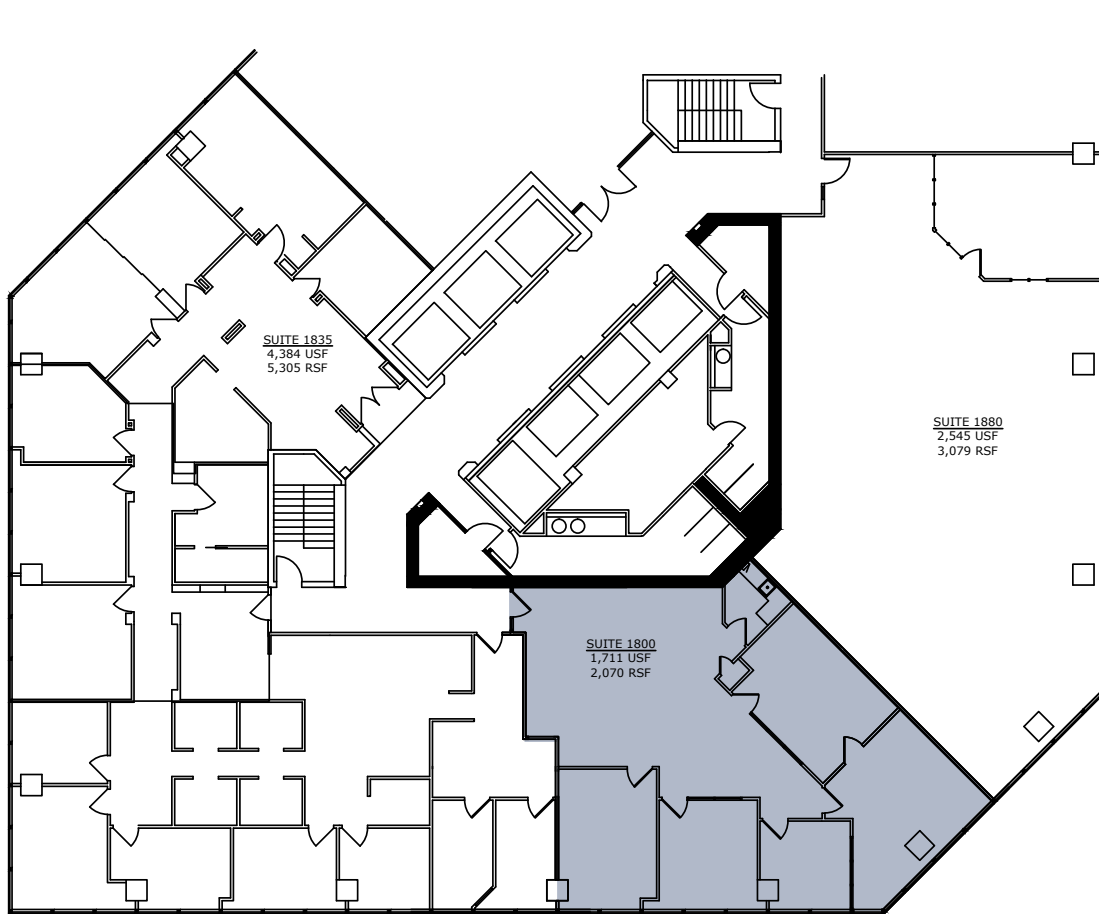

SCALE: NTS

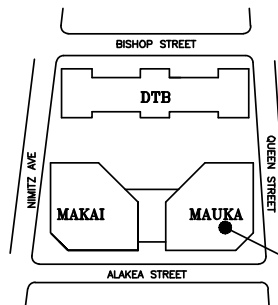

MAUKA TOWER
SUITE 1800, 1835 & 1880

8,640 Useable sq. ft.
10,454 Rentable sq. ft.

SUITE 1800, 1835 & 1880

Suite 1835 - 5,305 SF

737 Bishop Street, Mauka Tower

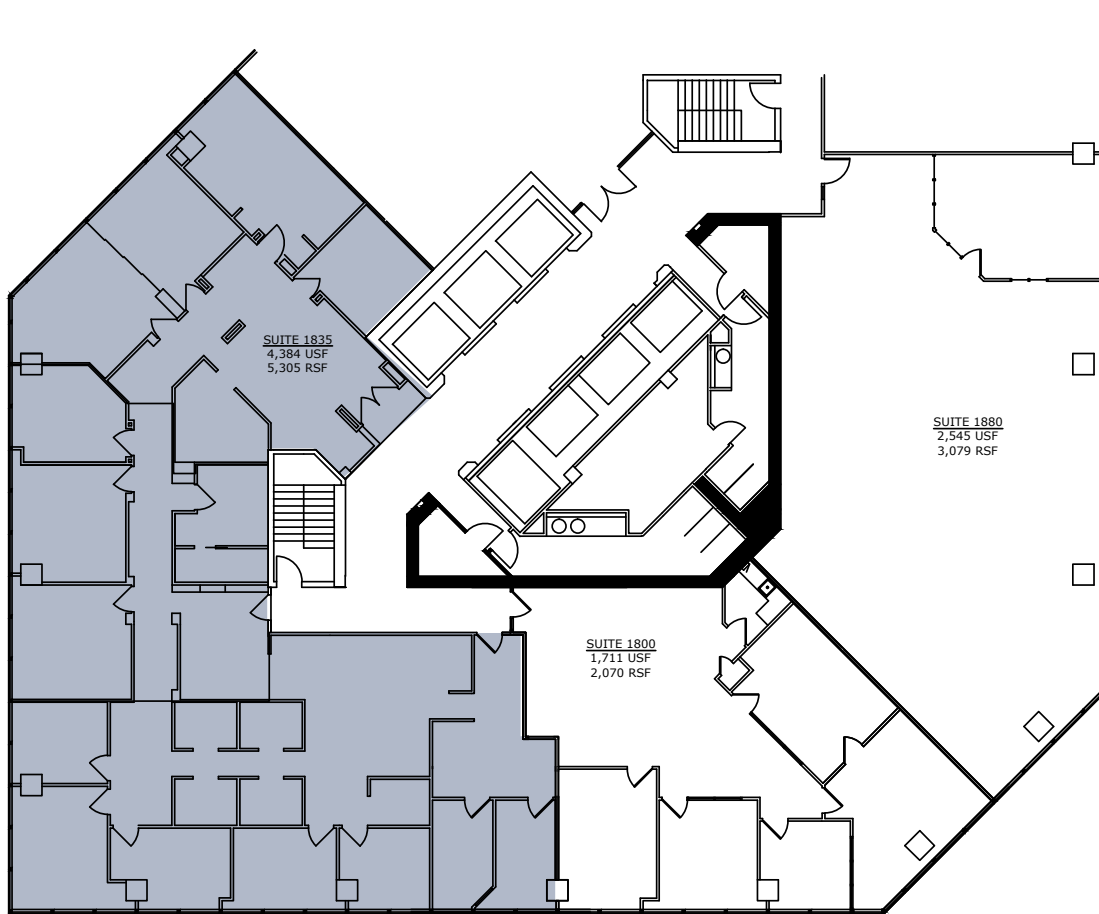

SCALE: NTS

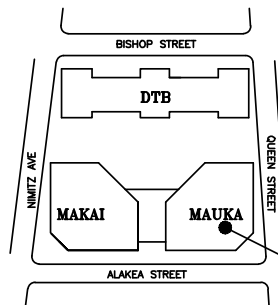

MAUKA TOWER
SUITE 1800, 1835 & 1880

8,640 Useable sq. ft.
10,454 Rentable sq. ft.

SUITE 1800, 1835 & 1880

Suite 1880 - 3,079 SF

737 Bishop Street, Mauka Tower

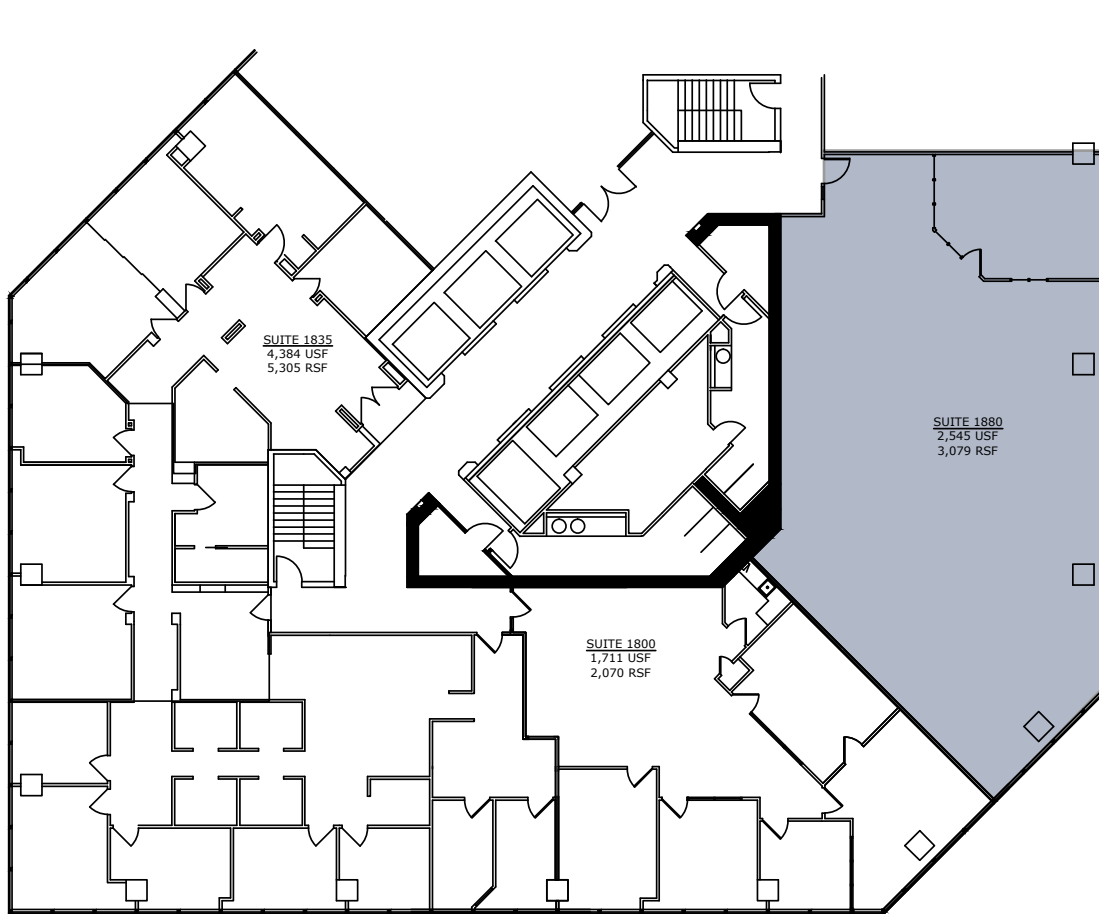

SCALE: NTS

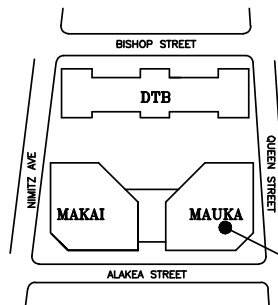

MAUKA TOWER
SUITE 1800, 1835 & 1880

8,640 Useable sq. ft.
10,454 Rentable sq. ft.

SUITE 1800, 1835 & 1880

Suite 1950 - 6,132 SF

737 Bishop Street, Mauka Tower

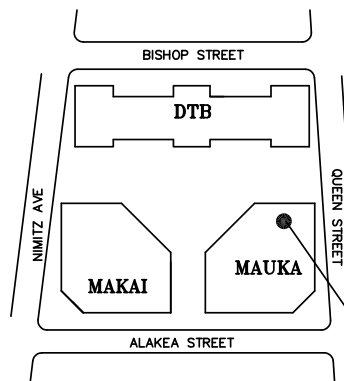
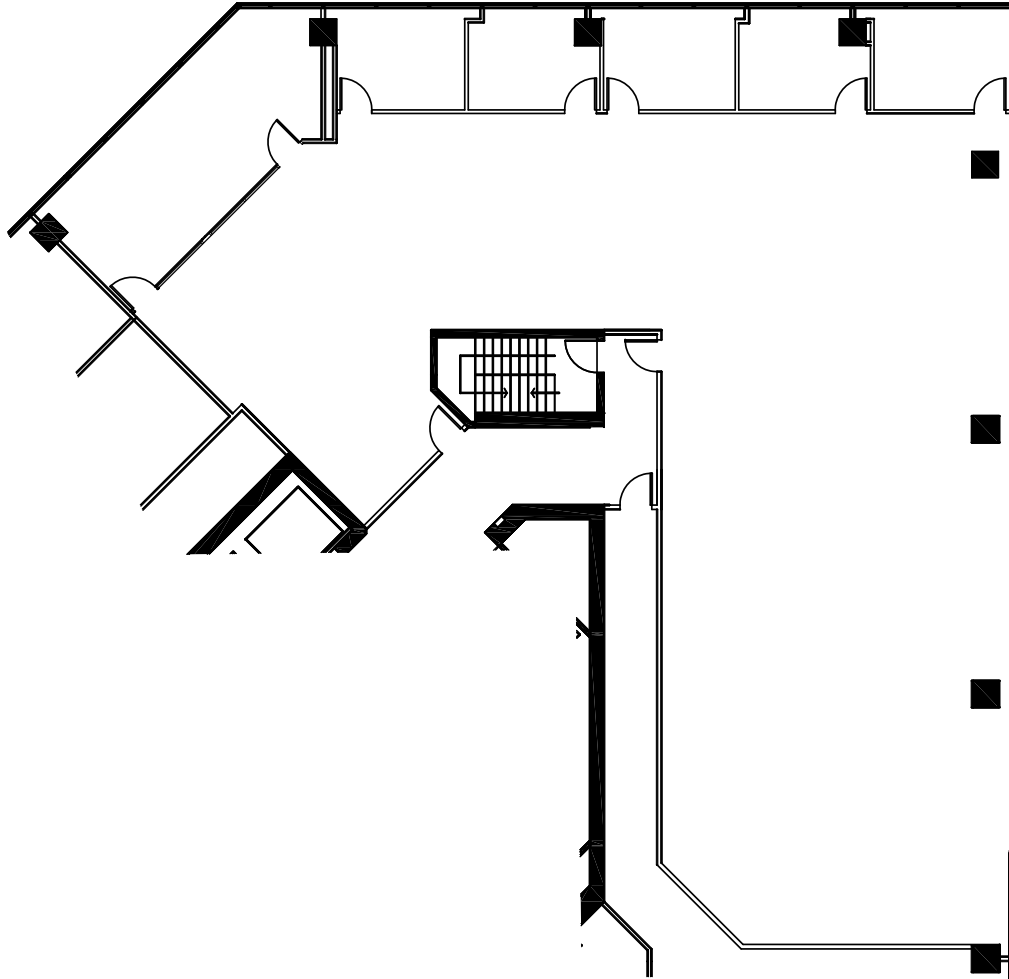

**MAUKA TOWER
SUITE 1950**

4,829 Useable sq. ft.
5,843 Rentable sq. ft.

SUITE 1950

Suite 2115 - 3,924 SF

737 Bishop Street, Mauka Tower

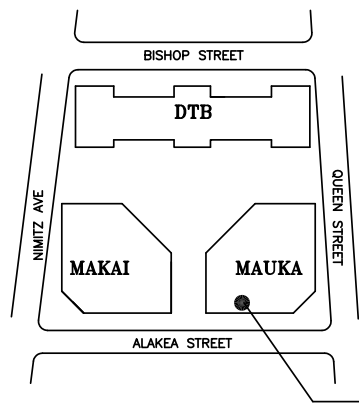
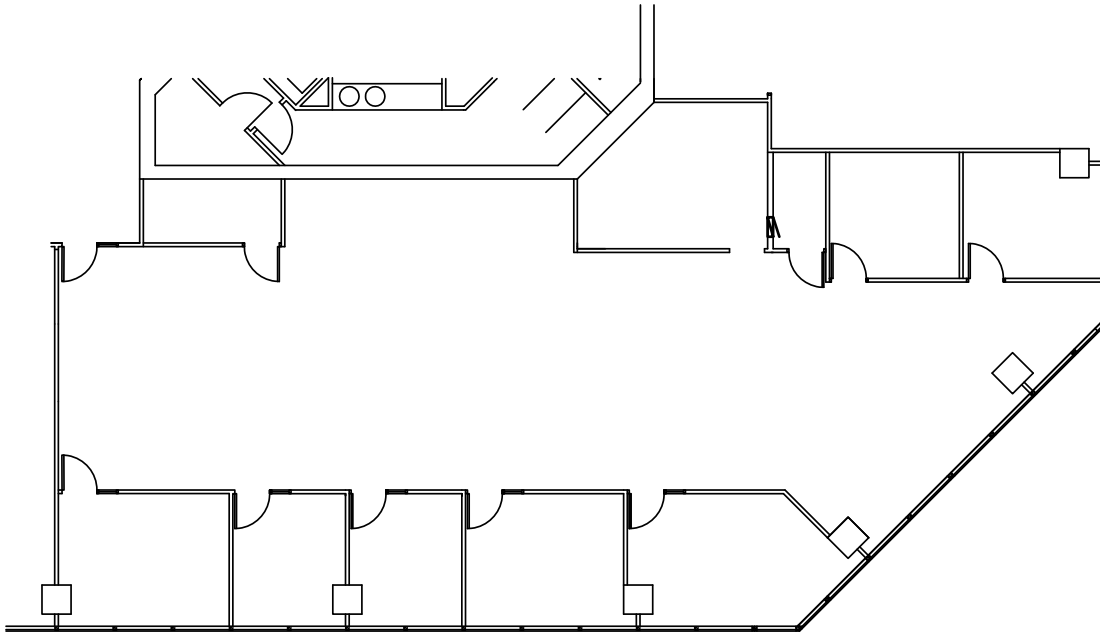

N.T.S.

**MAUKA TOWER
SUITE 2115**

3,243 Useable sq. ft.
3,924 Rentable sq. ft.

Suite 2340 - 5,271 SF

737 Bishop Street, Mauka Tower

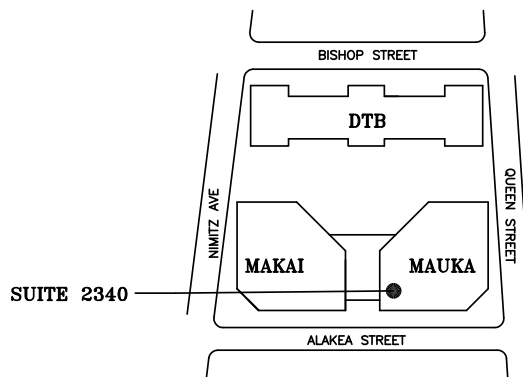
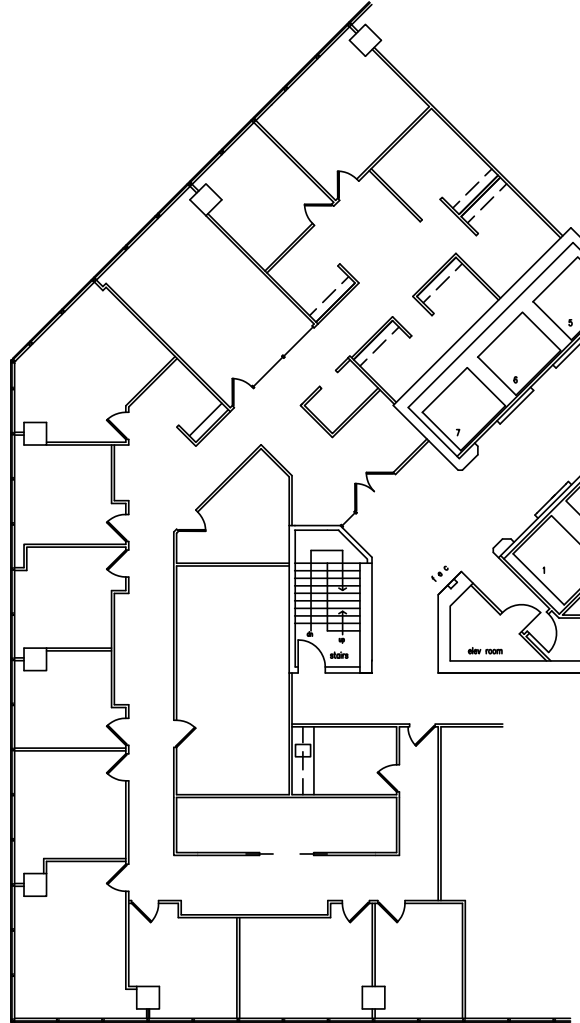

SCALE: NTS

**MAUKA TOWER
SUITE 2340**

4,356 Useable sq. ft.
5,271 Rentable sq. ft.

Suite 2360 - 791 SF

737 Bishop Street, Mauka Tower

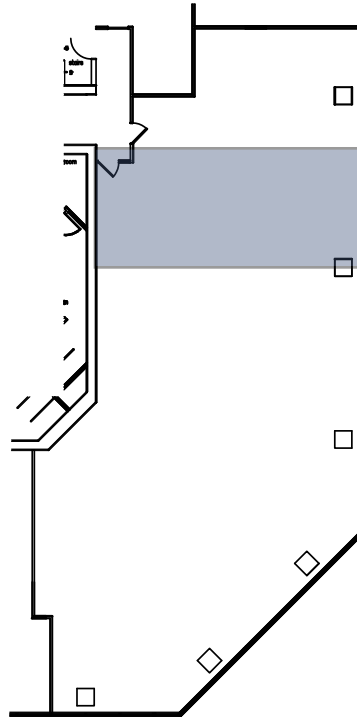

SCALE: NTS

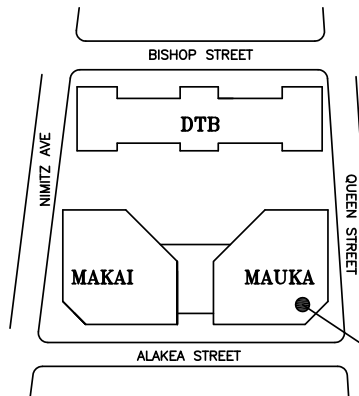

MAUKA TOWER
SUITE 2360, 2375 & 2390

3,672 Useable sq. ft.
4,443 Rentable sq. ft.

MAUKA 2360, 2375 & 2390

Suite 2375 - 519 SF

737 Bishop Street, Mauka Tower

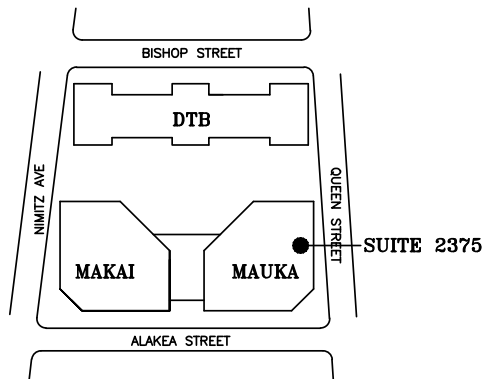
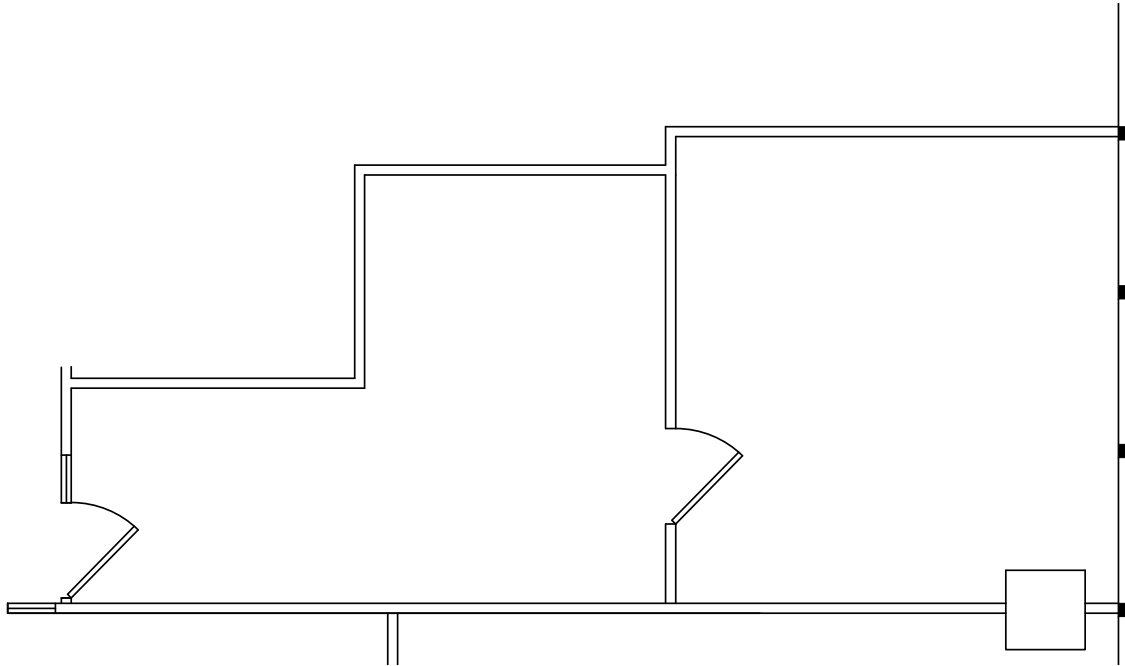

SCALE: 3/16" = 1'-0"

**MAUKA TOWER
SUITE 2375**

429 Useable sq. ft.
519 Rentable sq. ft.

Suite 2390 - 3,133 SF

737 Bishop Street, Mauka Tower

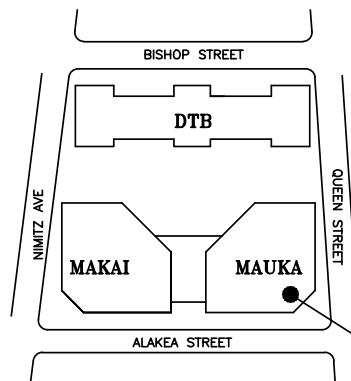
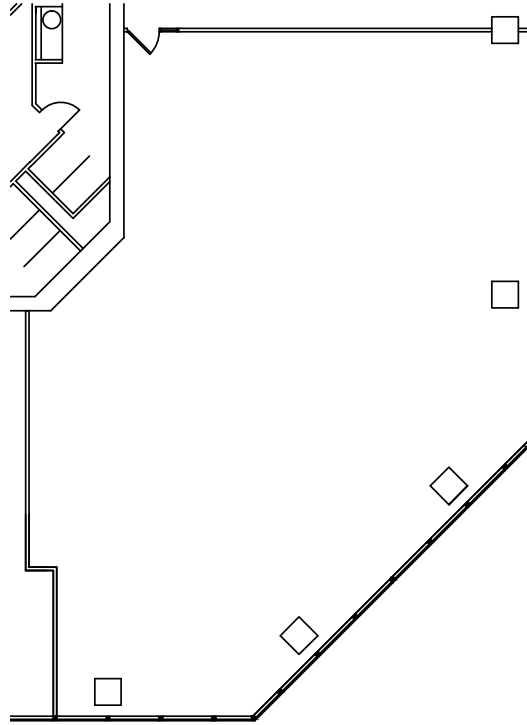

SCALE: 1/16" = 1'-0"

**MAUKA TOWER
SUITE 2390**

2,589 Useable sq. ft.
3,133 Rentable sq. ft.

Suite 2400 - 9,714 SF

737 Bishop Street, Mauka Tower

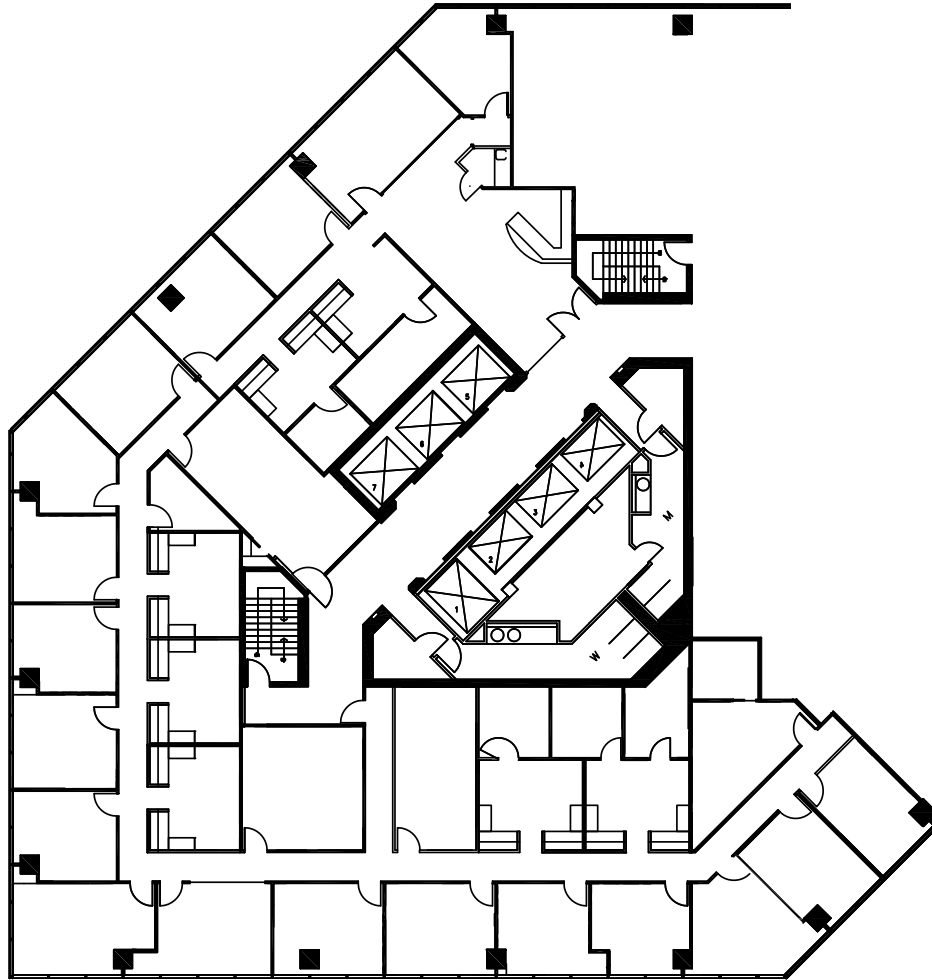

SCALE: NTS

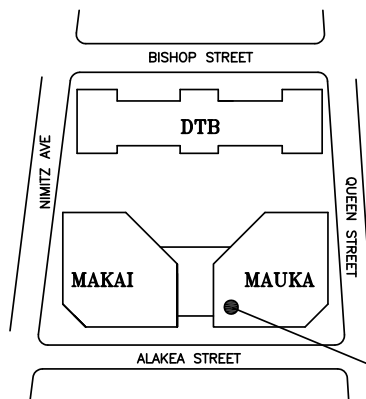

**MAUKA TOWER
SUITE 2400**

8,028 Useable sq. ft.
9,714 Rentable sq. ft.

Suite 2520 - 702 SF

737 Bishop Street, Mauka Tower

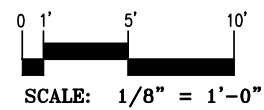
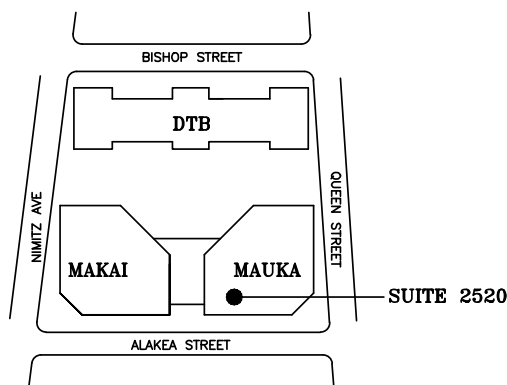
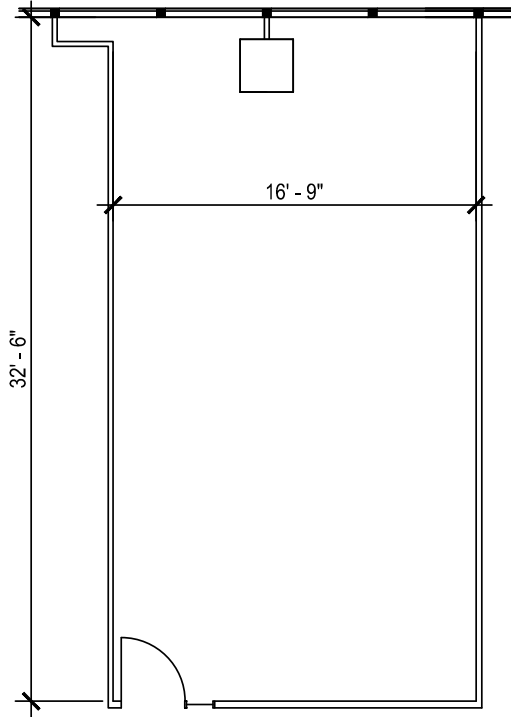

**MAUKA TOWER
SUITE 2520**

**580 Useable sq. ft.
702 Rentable sq. ft.**

Dillingham Transportation Plaza Floor Plans



Suite 200 - 1,641 SF

735 Bishop Street

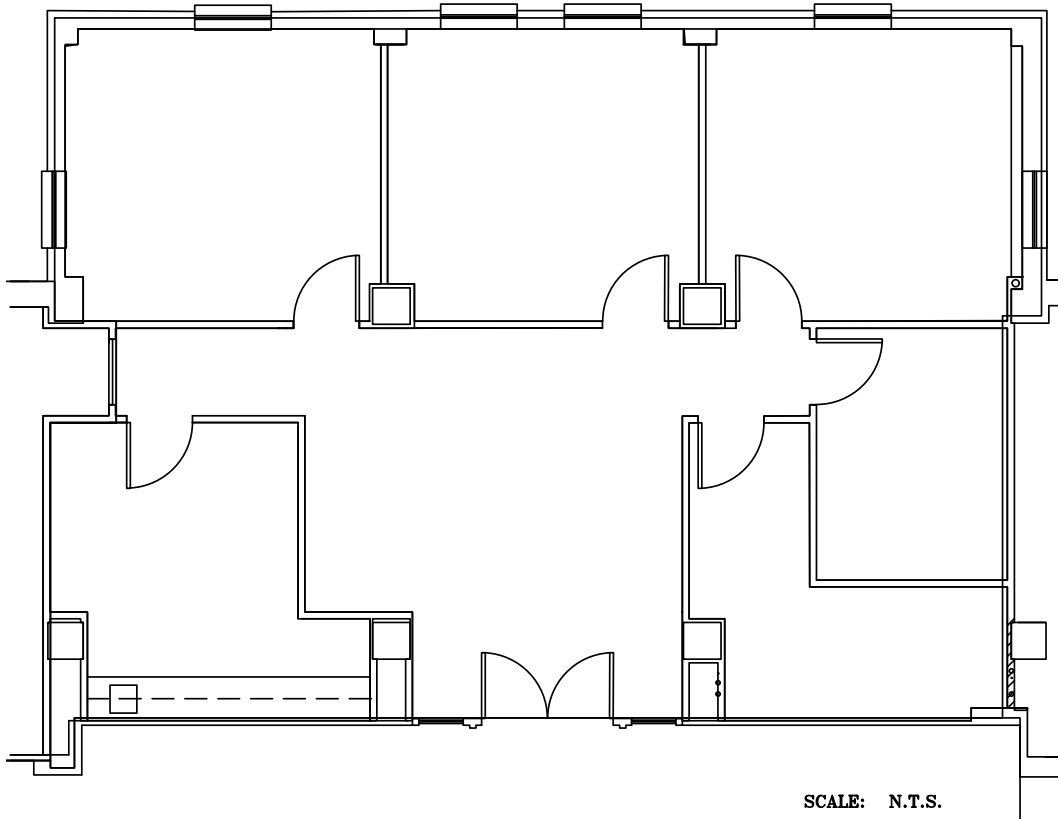

SCALE: N.T.S.

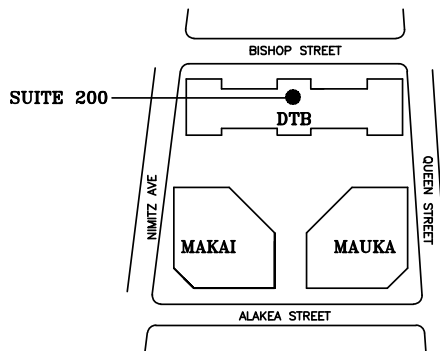

**DILLINGHAM
TRANSPORTATION
BUILDING
SUITE 200**

**USF: 1,492
RSF: 1,641**

Suite 215 - 314 SF

735 Bishop Street

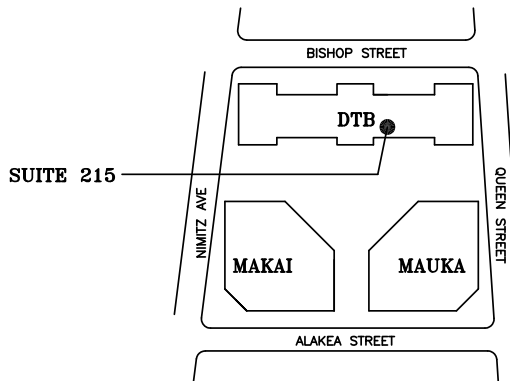
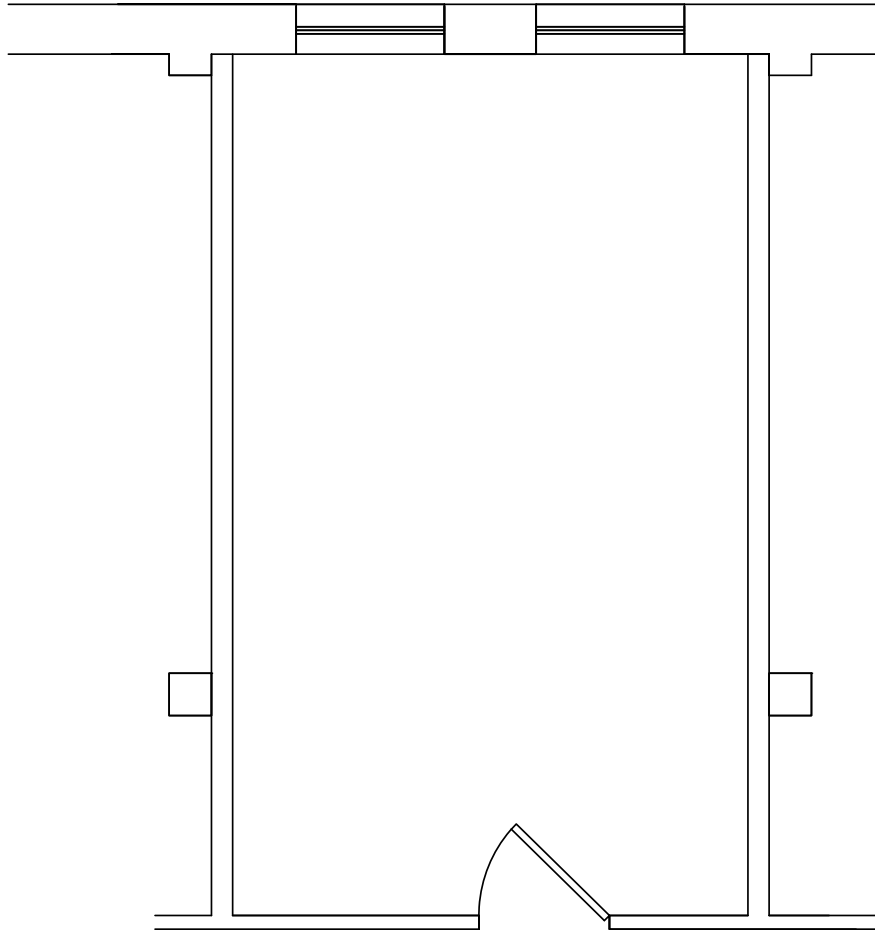

SCALE: 1/4" = 1'-0"

**DILLINGHAM
TRANSPORTATION
BUILDING
SUITE 215**

286 Useable sq. ft.
314 Rentable sq. ft.

Suite 223 - 361 SF

735 Bishop Street

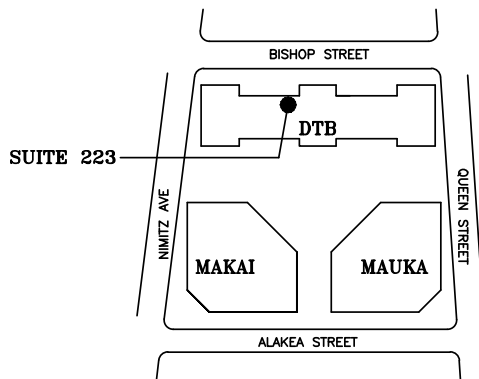
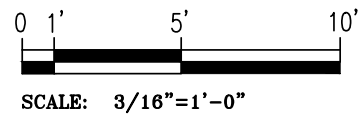
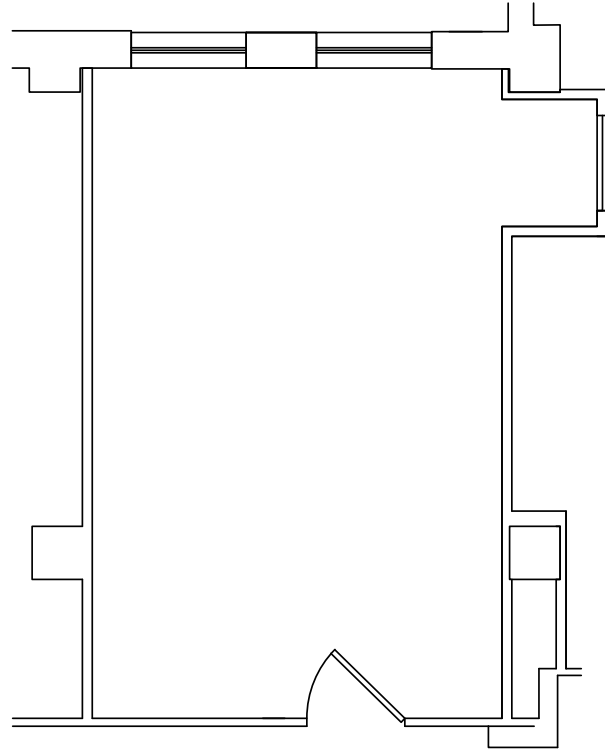

DILLINGHAM
TRANSPORTATION
BUILDING
SUITE 223

328 Useable sq. ft.
361 Rentable sq. ft.

Suite 230 - 3,170 SF

735 Bishop Street

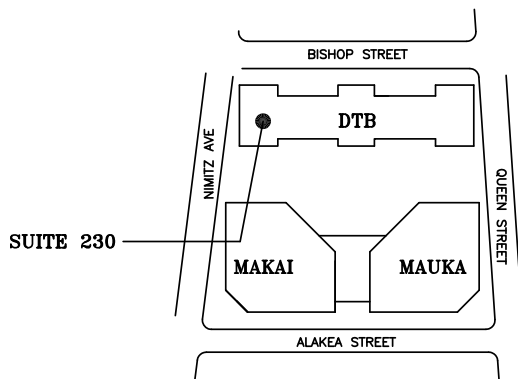
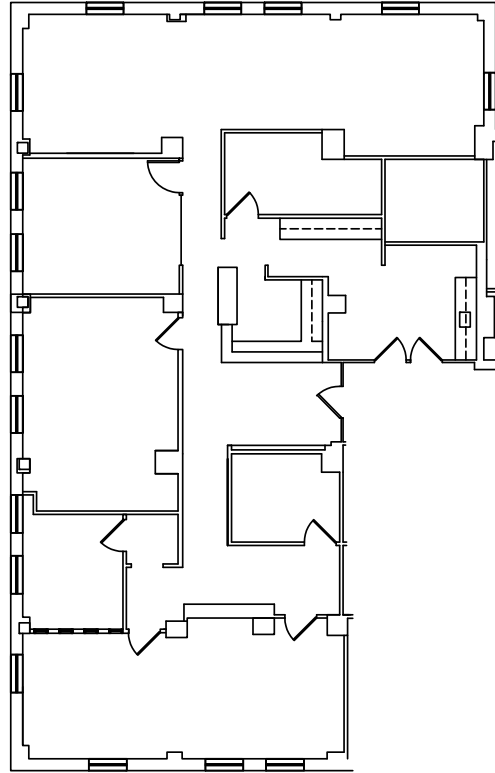

SCALE: 1/16"=1'-0"

DILLINGHAM
TRANSPORTATION
BUILDING
SUITE 230

2,882 Useable sq. ft.
3,170 Rentable sq. ft.

Suite 233 - 499 SF

735 Bishop Street

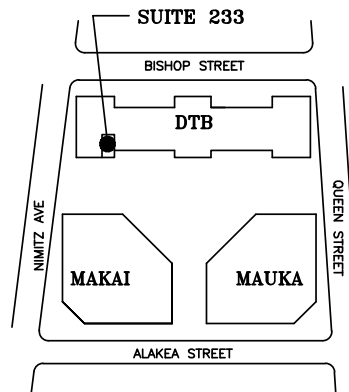
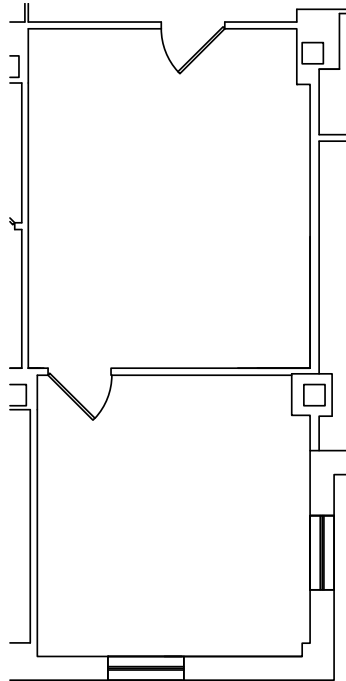

SCALE: 1/8"=1'-0"

**DILLINGHAM
TRANSPORTATION
BUILDING
SUITE 233**

454 Useable sq. ft.
499 Rentable sq. ft.

Suite 236 - 344 SF

735 Bishop Street

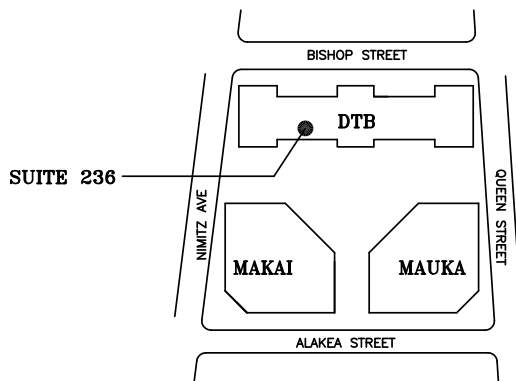
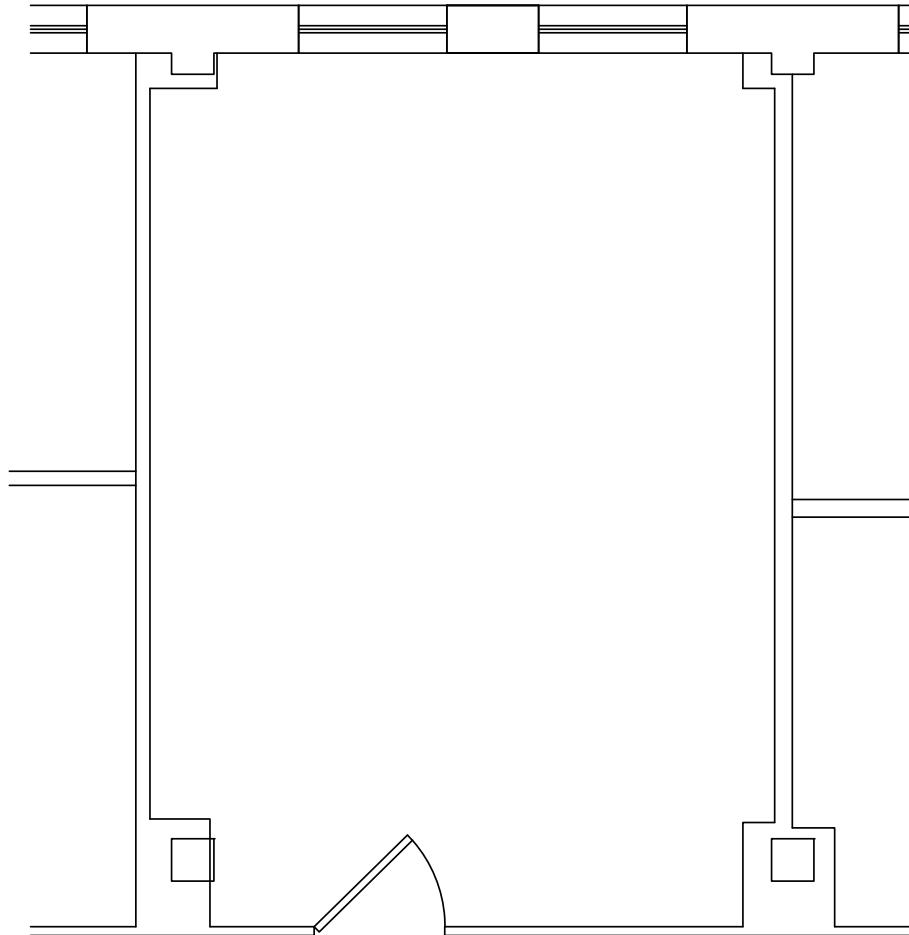

SCALE: 1/4" = 1'-0"

**DILLINGHAM
TRANSPORTATION
BUILDING
SUITE 236**

**313 Useable sq. ft.
344 Rentable sq. ft.**

Suite 303 - 1,113 SF

735 Bishop Street

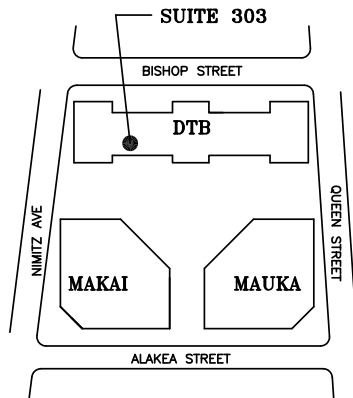
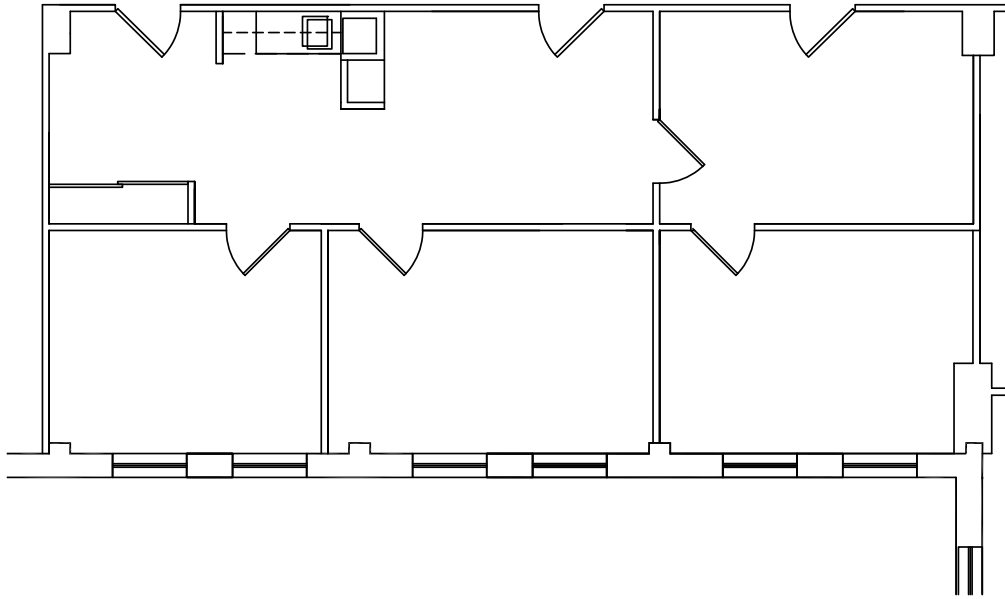

SCALE: NONE

DILLINGHAM
TRANSPORTATION
BUILDING
SUITE 303

1,012 Useable sq. ft.
1,113 Rentable sq. ft.

Suite 308 - 708 SF

735 Bishop Street

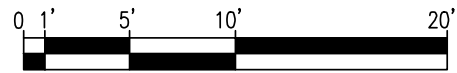
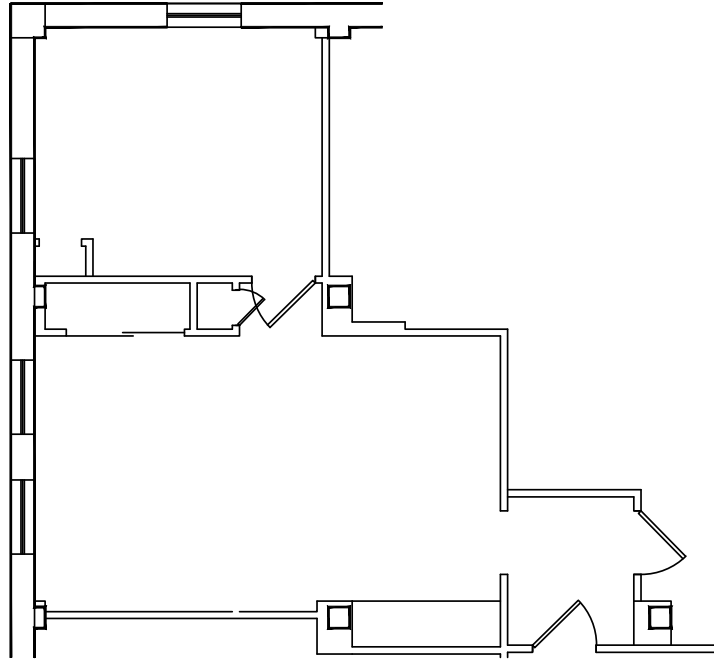

SCALE: 1/8"=1'-0"

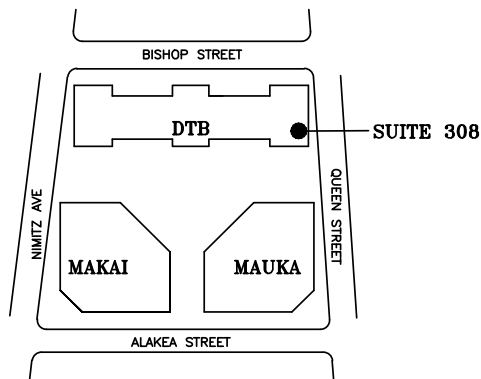

**DILLINGHAM
TRANSPORTATION
BUILDING
SUITE 308**

**USF: 644 s.f.
RSF: 708 s.f.**

Suite 314 - 402 SF

735 Bishop Street

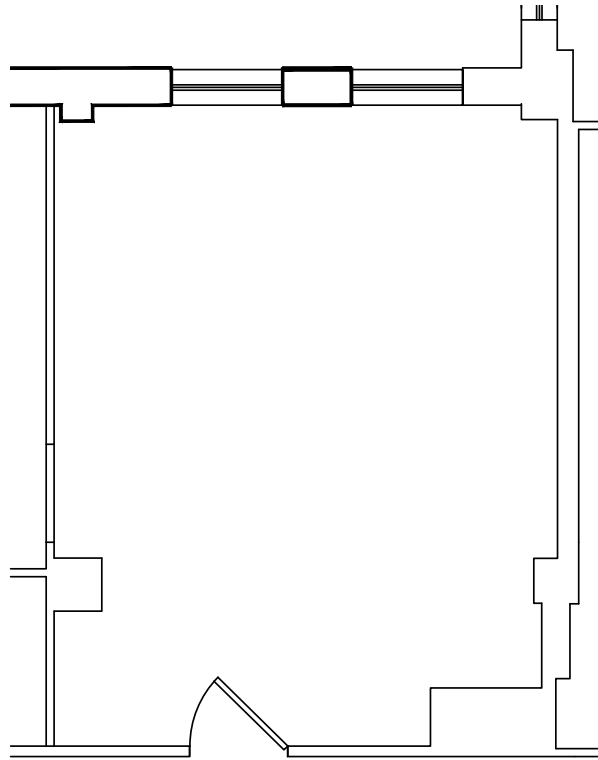

SCALE: 3/16"=1'-0"

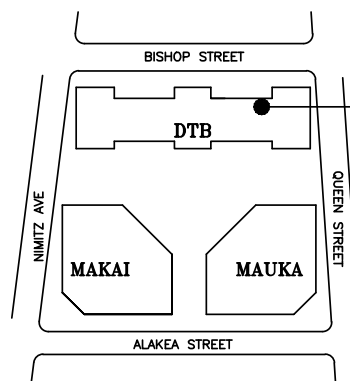

SUITE 314 DILLINGHAM
TRANSPORTATION
BUILDING
SUITE 314

USF: 366 s.f.
RSF: 402 s.f.

Suite 315 - 317 SF

735 Bishop Street

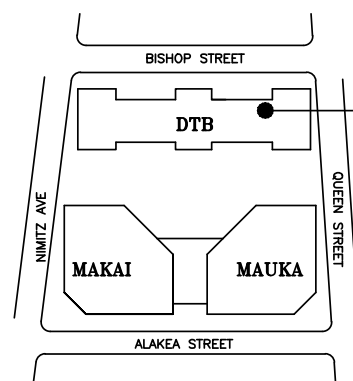
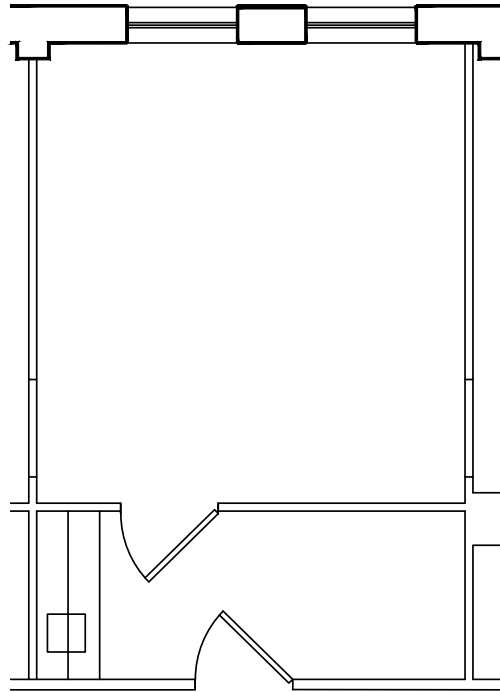

**DILLINGHAM
TRANSPORTATION
BUILDING**

SUITE 315

**288 Useable sq. ft.
317 Rentable sq. ft.**

Suite 325 - 713 SF

735 Bishop Street

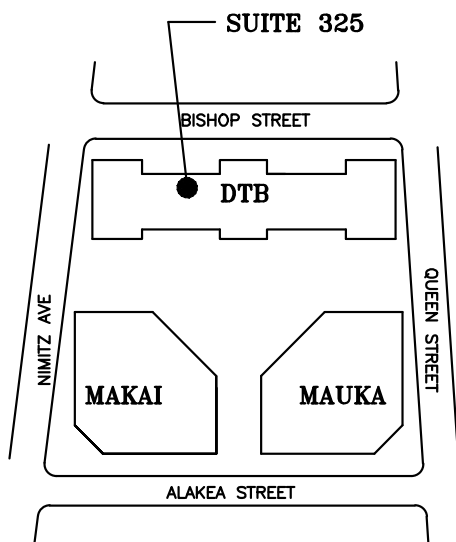
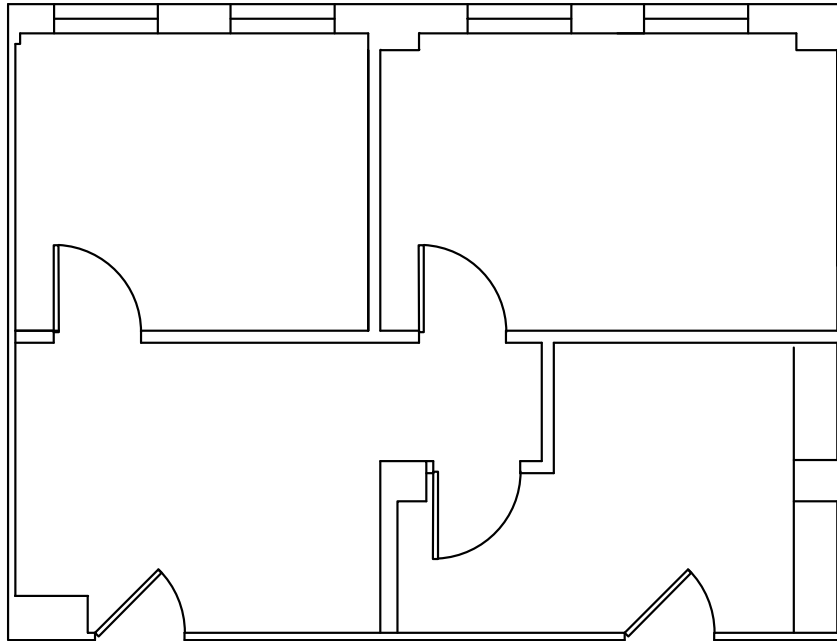

SCALE: 1/8"=1'-0"

**DILLINGHAM
TRANSPORTATION
BUILDING
SUITE 325**

**648 Useable sq. ft.
713 Rentable sq. ft.**

Suite 330 - 2,092 SF

735 Bishop Street

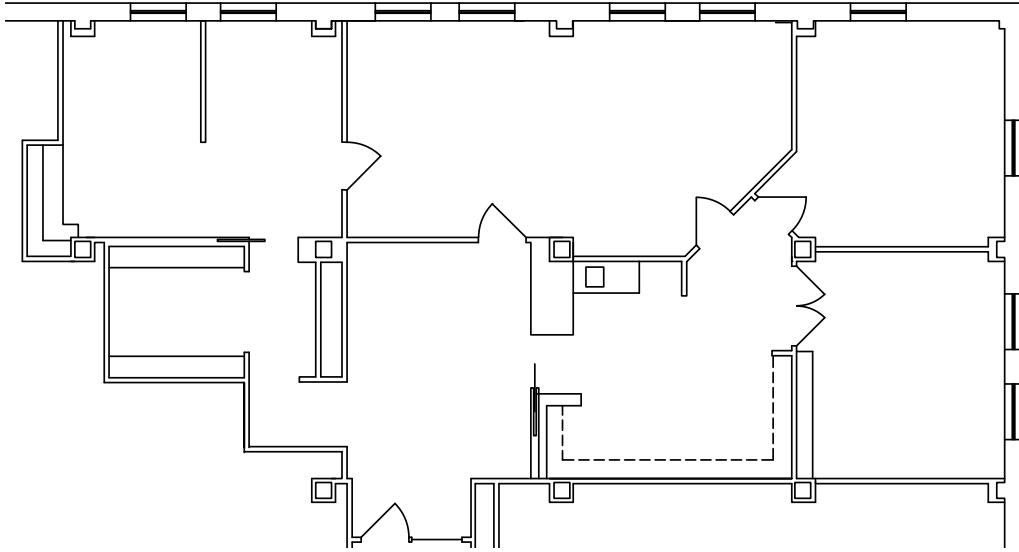

SCALE: 3/32"=1'-0"

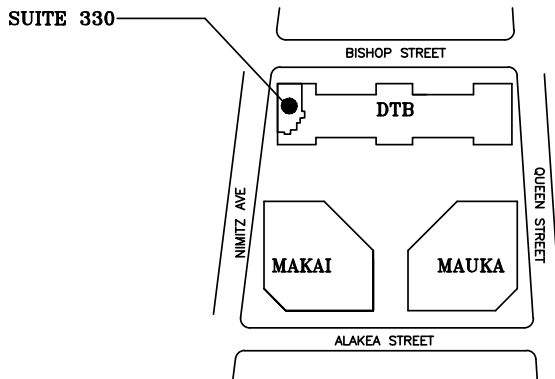

**DILLINGHAM
TRANSPORTATION
BUILDING
SUITE 330**

1,902 Useable sq. ft.
2,092 Rentable sq. ft.

Suite 333 - 1,669 SF

735 Bishop Street

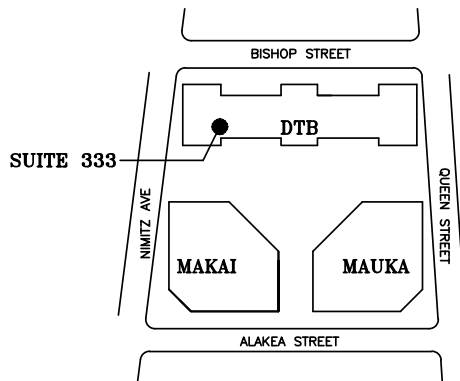
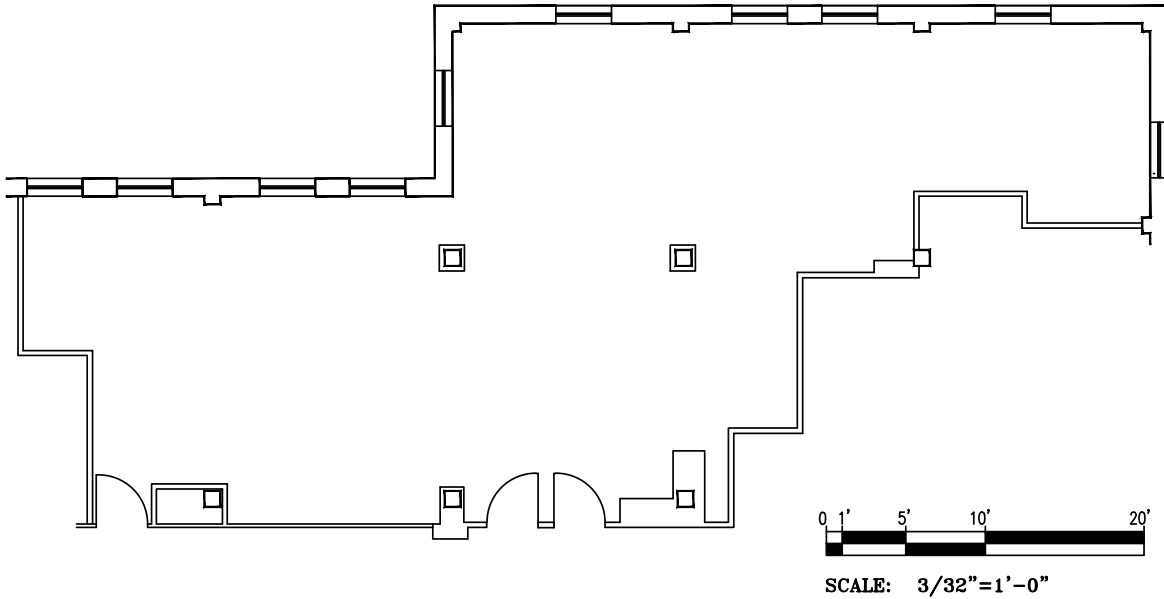

**DILLINGHAM
TRANSPORTATION
BUILDING
SUITE 333**

**USF: 1,517 s.f.
RSF: 1,669 s.f.**

Suite 336 - 533 SF

735 Bishop Street

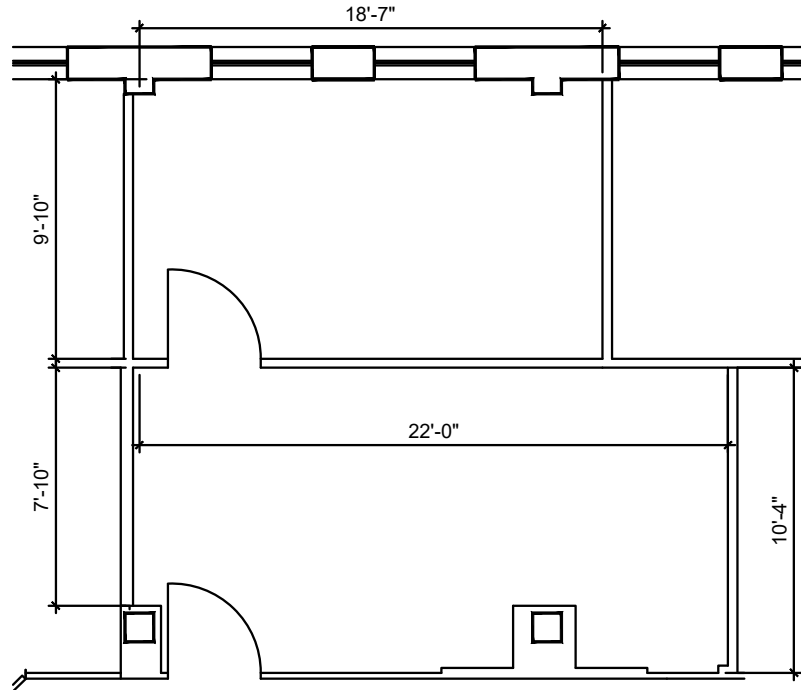

SCALE: 1/8"=1'-0"

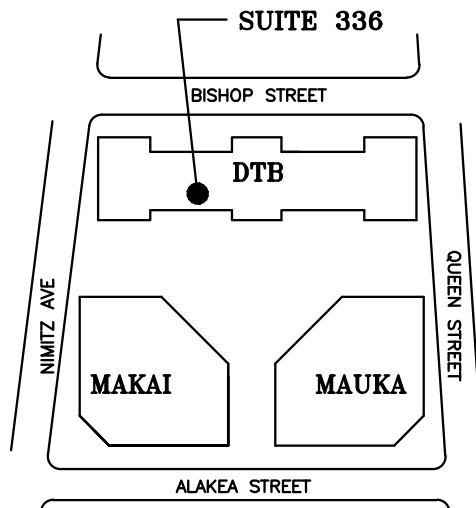

**DILLINGHAM
TRANSPORTATION
BUILDING
SUITE 336**

**484 Useable sq. ft.
533 Rentable sq. ft.**

Suite 412 - 780 SF

735 Bishop Street

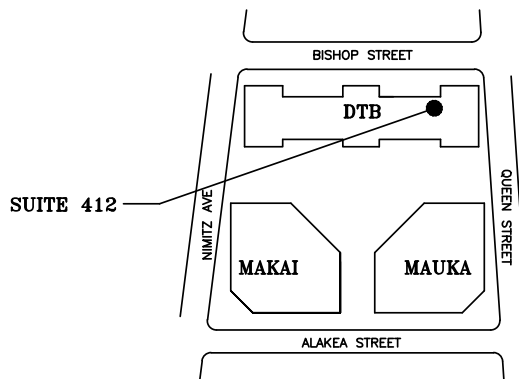
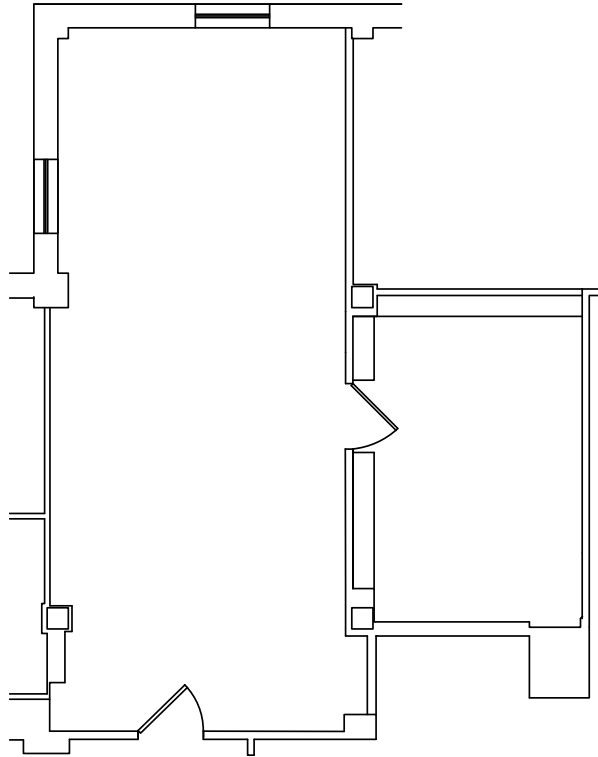

**DILLINGHAM
TRANSPORTATION
BUILDING
SUITE 412**

**709 Useable sq. ft.
780 Rentable sq. ft.**

Suite 432 - 632 SF

735 Bishop Street

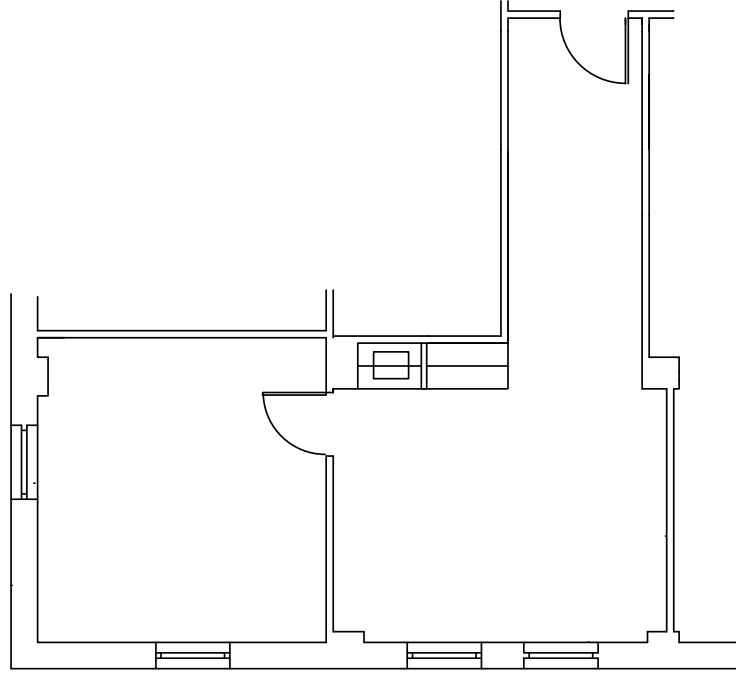

1/8" = 1'-0"

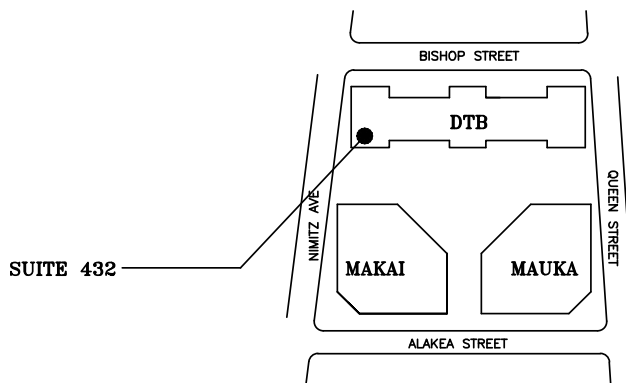

**DILLINGHAM
TRANSPORTATION
BUILDING
SUITE 432**

574 Useable sq. ft.
632 Rentable sq. ft.



Exclusive Listing Agents

Brandon Bera (B) CCIM SIOR*

Lic# RB-24145

808 523 8309

brandon.bera@colliers.com

Karen Birkett (S) SIOR

Lic# RS-50512

808 523 9729

karen.birkett@colliers.com

Alexander Peach (S) CCIM SIOR

Lic# RS-76881

808 349 6538

alexander.peach@colliers.com

*BKB Real Estate Services LLC. Exclusively contracted by Colliers International HI, LLC. This document/email has been prepared by Colliers for advertising and general information only. Colliers makes no guarantees, representations or warranties of any kind, expressed or implied, regarding the information including, but not limited to, warranties of content, accuracy and reliability. Any interested party should undertake their own inquiries as to the accuracy of the information. Colliers excludes unequivocally all inferred or implied terms, conditions and warranties arising out of this document and excludes all liability for loss and damages arising there from. This publication is the copyrighted property of Colliers and /or its licensor(s). © 2025. All rights reserved. This communication is not intended to cause or induce breach of an existing listing agreement.