



1,774 SF RETAIL / OFFICE SPACE FOR LEASE
 IN LOHI

2926 ZUNI ST
 DENVER, CO 80211

Property Features

Property Summary

- **Prime LoHi Corner at 29th & Zuni** — High-visibility location in one of Denver's most active neighborhoods with steady foot traffic.
- **1,774 SF Available** — Efficient space ideal for retail, service, office, or creative users looking for a strong LoHi presence.
- **Walkable, Amenity-Rich Area** — Surrounded by top restaurants, bars, and boutique retail that drive consistent day and night traffic.
- **Built-In Customer Base** — 28 residential units on-site provide immediate, convenience-driven traffic.
- **Under New Ownership** — Recent renovations focused on improving curb appeal and functionality.
- **Delivered White Box** — Clean, refreshed space ready for tenant buildout.

Lease Rate	\$27/SF NNN
County	Denver
Zoning	G-MS-3
Suite Size	1,774 SF (867 SF Main Level, 907 SF Lower Level)
Parking	Street + Ability to Rent Spaces Nearby
Year Built/Renovated	1891/2026

For more information:

LEAD

Brett MacDougall

Senior Vice President

303.512.2736

bmacdougall@uniqueprop.com

LEAD

Hudson Cramer

Senior Broker Associate

303.512.1154

hcramer@uniqueprop.com

Michael DeSantis

Senior Vice President

303.512.1194

mdesantis@uniqueprop.com



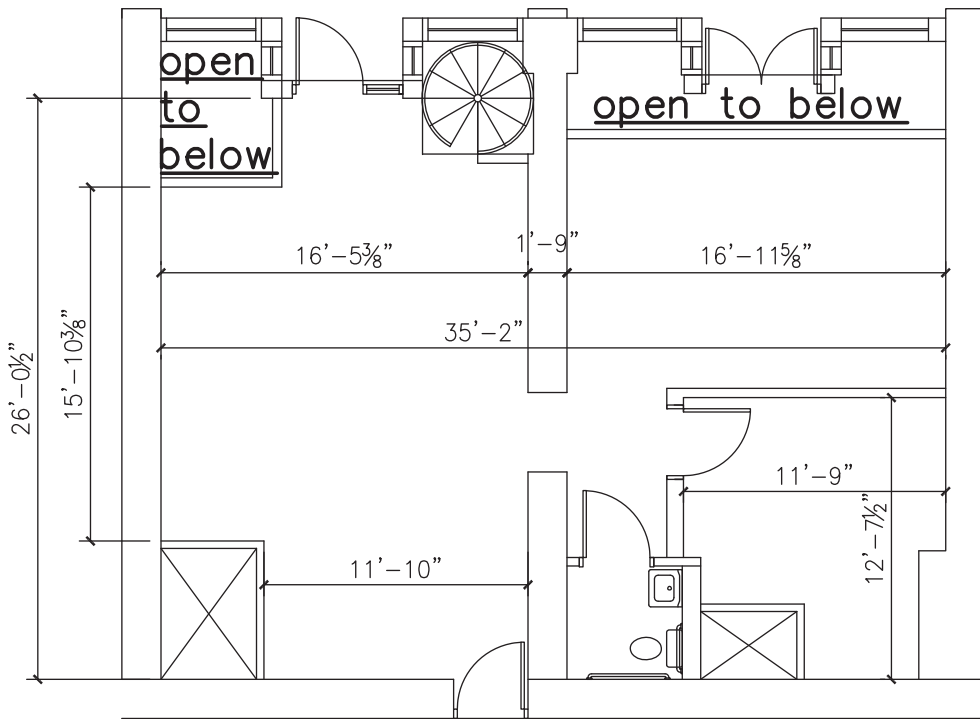

main level: 867 SF

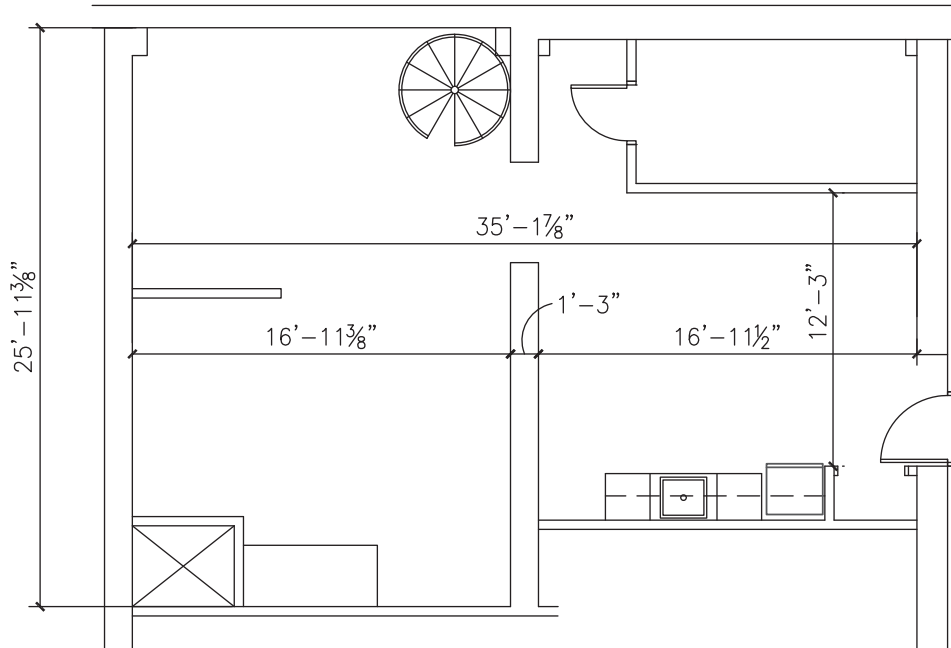

lower level: 907 SF

TOTAL: 1,774 SF

2926 Zuni St
Denver CO 80211

2926 ZUNI ST DENVER, CO

Unique Properties
400 S Broadway | Denver, CO 80209
303.321.5888 | UNIQUEPROP.COM



For more information:



LEAD

Brett MacDougall

Senior Vice President

303.512.2736

bmacdougall@uniqueprop.com

LEAD

Hudson Cramer

Senior Broker Associate

303.512.1154

hcramer@uniqueprop.com

Michael DeSantis

Senior Vice President

303.512.1194

mdesantis@uniqueprop.com