



**760 E. Main Street
Lewisville, Tx. 75057**



***WorkSpace Office, Warehouse
& Secured Parking***

ALLTRADES INDUSTRIAL PROPERTIES

www.855AllTrades.com

Location

ADDRESS

760 E. Main Street, Lewisville Tx. 75057

FEATURES

WorkSpace Shops:

- 2,600 to 5,800 SF
- Two story office with two restrooms

WorkSpace Studios:

- 1,870 to 3,740 SF
- Single story office w/ mezzanine storage, one restroom

All units have:

- Ground floor kitchenette (*includes upper and lower cabinets, sink, bar fridge & dishwasher*)
- Community forklift for use by all tenants
- Fire suppression system in all offices, mezzanines & warehouses
- Controlled access gates & 24/7 video
- Base utilities included (subject to limitations)

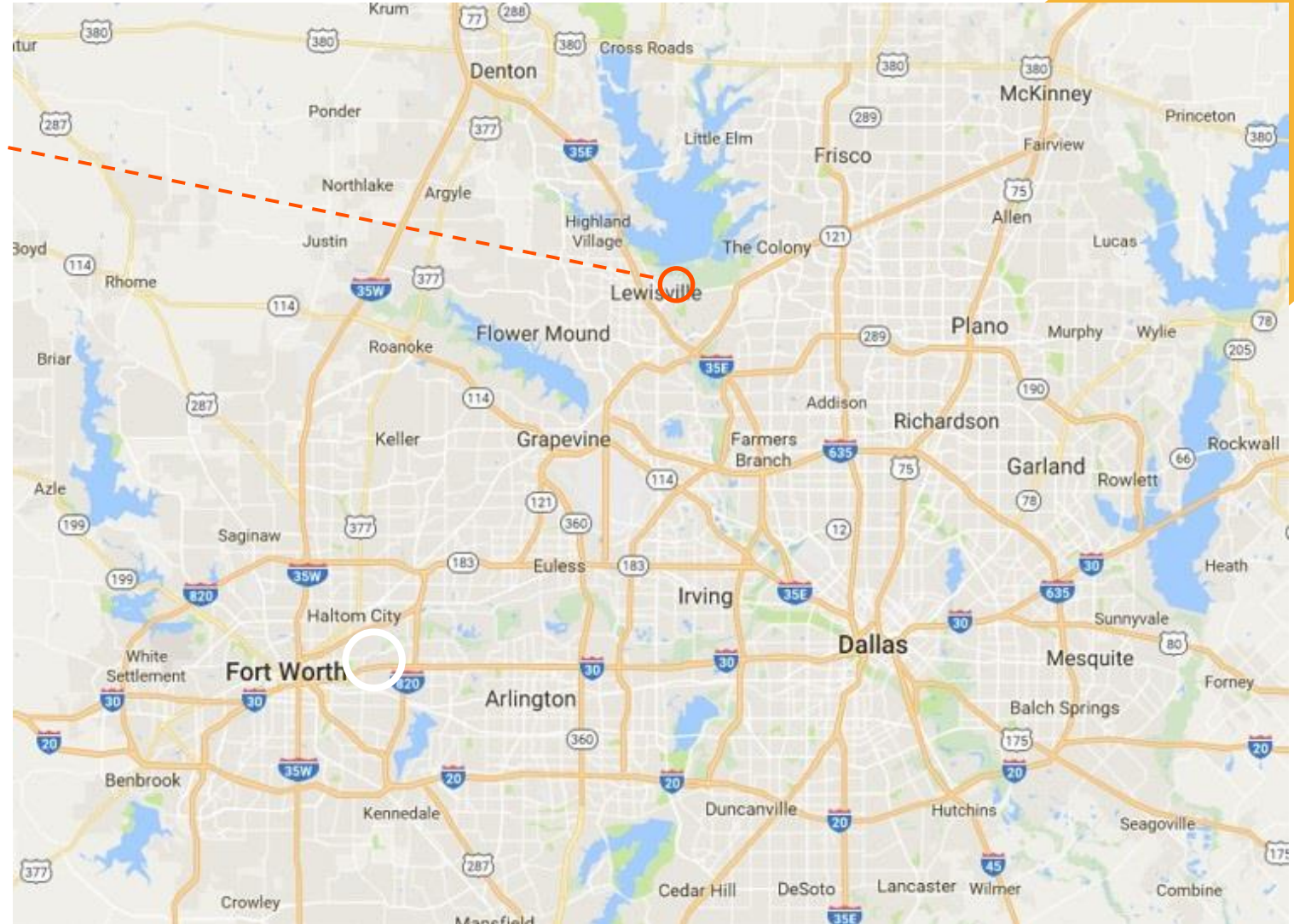

AllTrades Product Offering

Distinct options to suit diverse range of tenant needs

WorkSpace Shops™



WorkSpace Shops™ that range in size from 2,600 to 5,800 sq. ft. comprised of approx. 50% high quality, fully finished out office space and 50% warehouse. Office is climate controlled, and warehouse is heated but can be climate controlled if required.

WorkSpace Studios™



WorkSpace Studios™ that range in size from 1,870 to 3,740 sq. ft. comprised of approx. 25% fully finished office and 75% warehouse / storage. Office is climate controlled, and warehouse / storage is heated but can be climate controlled if required.

WorkSpace Secured Parking™



WorkSpace Secured Parking™ allows tenants to park their rolling stock trucks, trailers and equipment in a secured and 24/7 video-monitored location on the facility premises.

ALLTRADES INDUSTRIAL PROPERTIES
760 EAST MAIN STREET
LEWISVILLE, TX 75057

EAST MAIN STREET

WorkSpace Shops

- 2,900 to 5,800 SF

WorkSpace Secured Parking

- 10' x 30'

WorkSpace Shops

- 2,600 to 5,200 SF

WorkSpace Studios

- 1,870 to 3,740 SF

Note: Shops & Studio units can be easily combined to double the unit size

EAST MAIN STREET



WorkSpace Shop Floor Plan – 2,600 SF

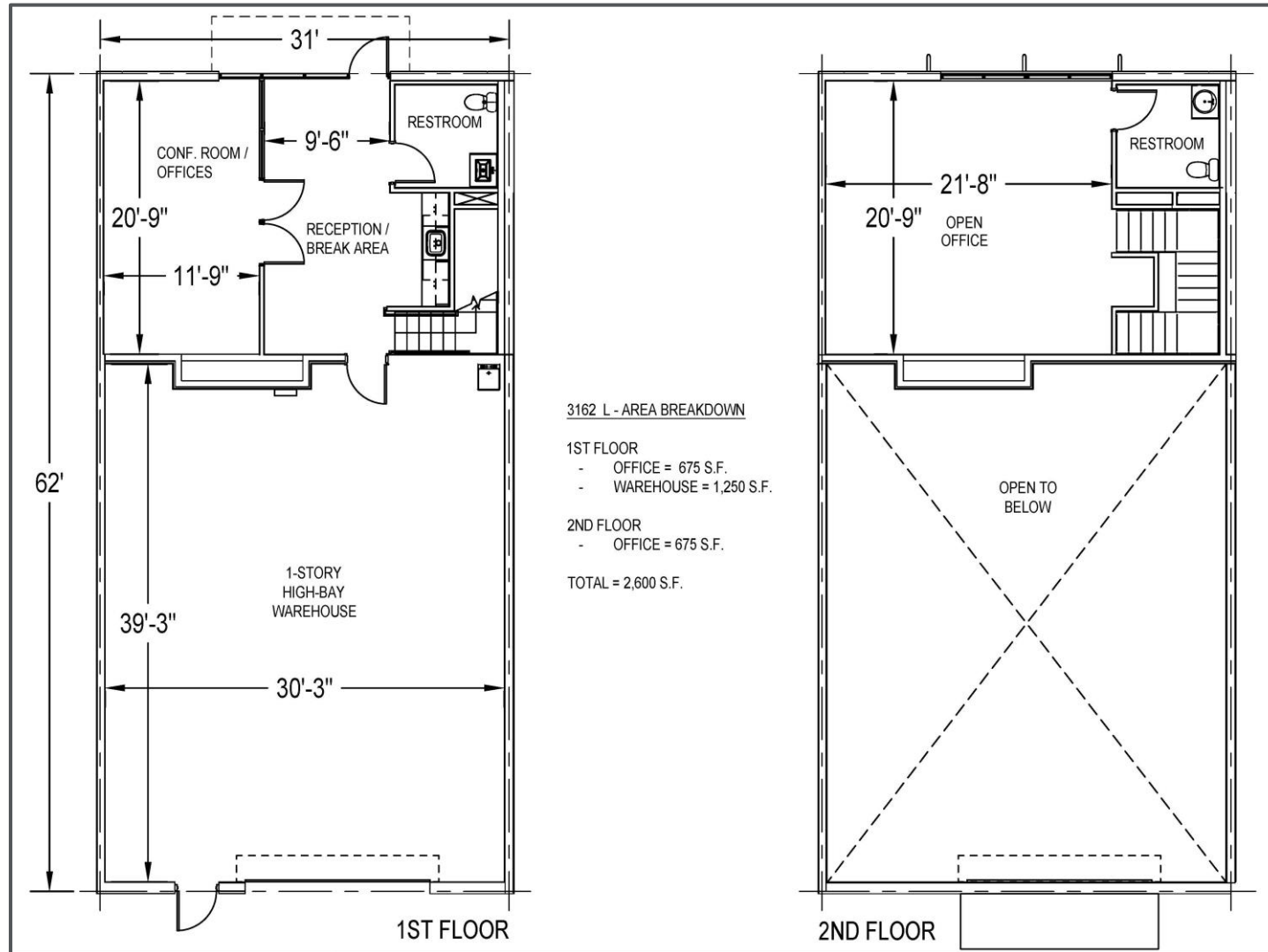

WorkSpace Shop Floor Plan – 2,900 SF (Note: front entry office & warehouse)

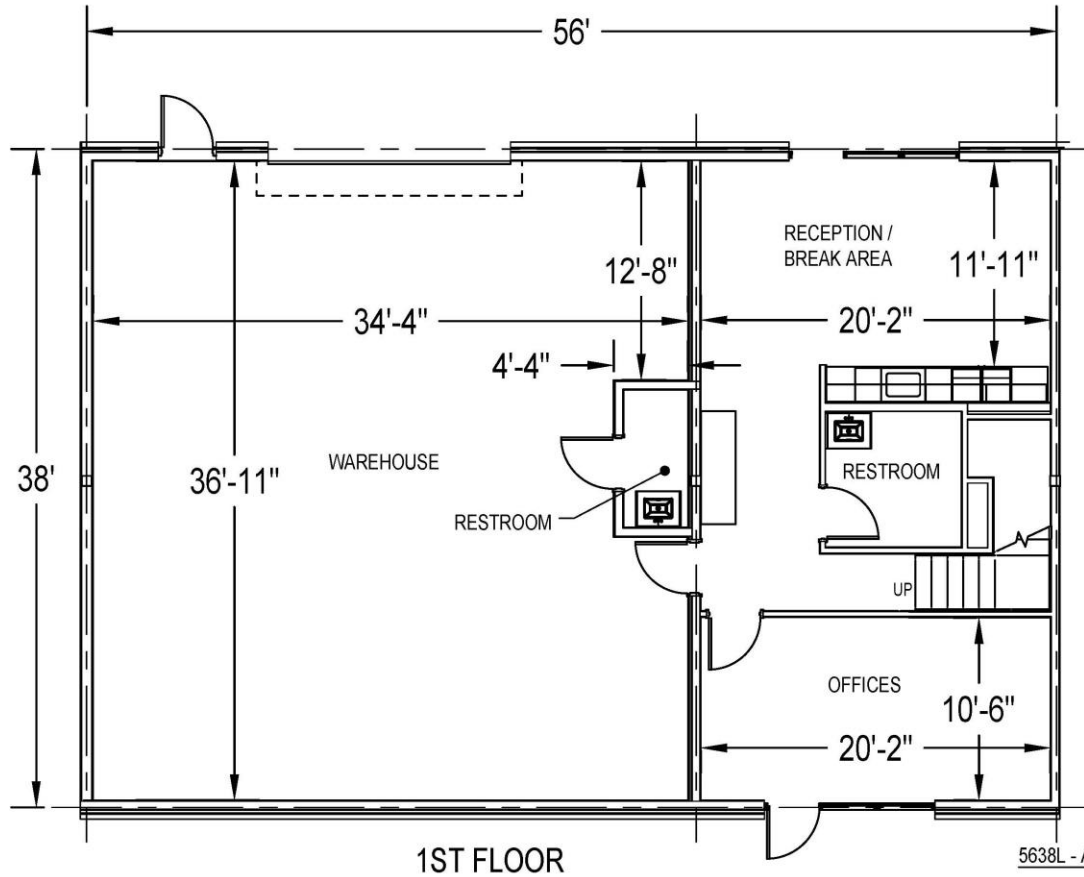

5638L - AREA BREAKDOWN

- 1ST FLOOR
- OFFICE = 785 S.F.
 - WAREHOUSE = 1,330 S.F.

- 2ND FLOOR
- OFFICE = 785 S.F.

TOTAL = 2,900 S.F.

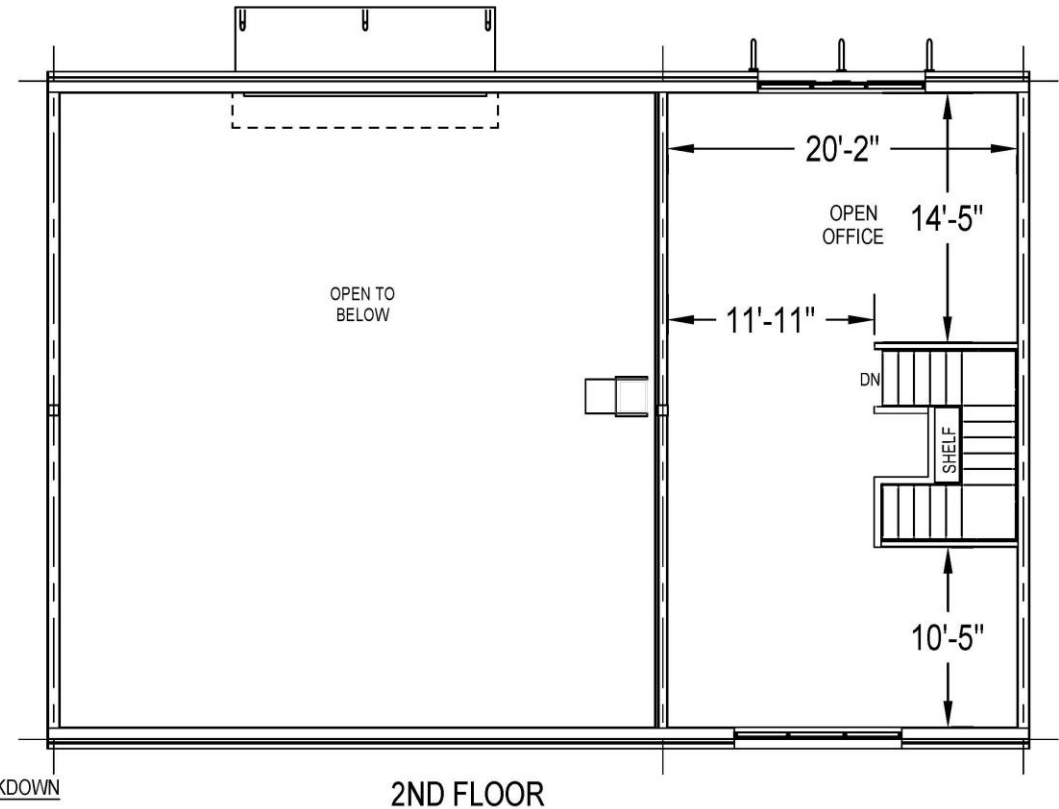

WorkSpace Studio Floor Plan – 1,870 SF (Note: front entry office & warehouse)

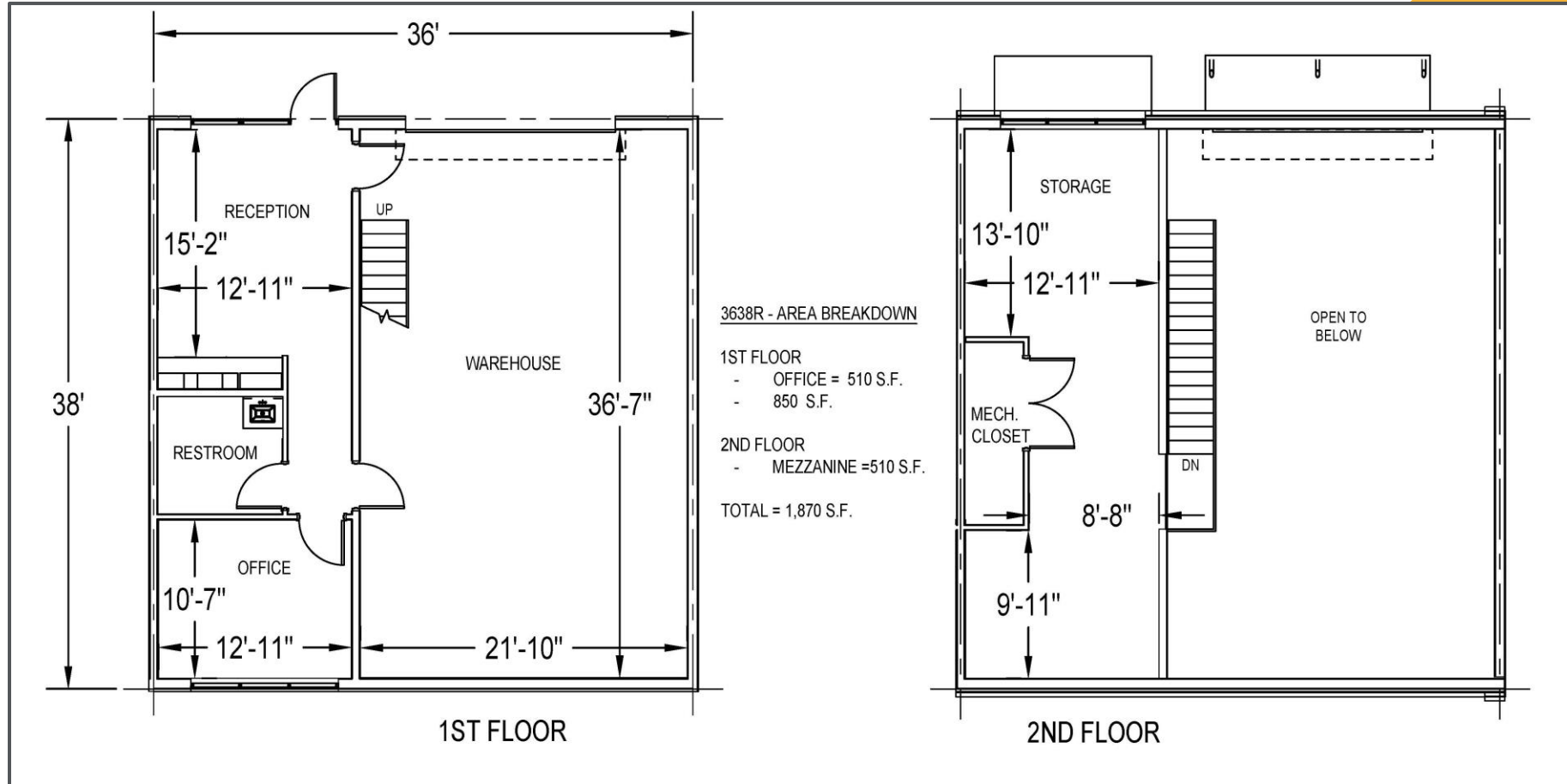

Why lease from AllTrades?

AllTrades is hyper focused on providing a quality product with all-inclusive services for tenants

UNIT FEATURES & AMENITIES

- Owner managed property
- All units include kitchenettes with sink, bar fridge and dishwasher
- Solid oak stairs & flooring in upstairs offices
- Epoxy flooring in ground floor offices
- Twice weekly office cleaning & restroom supplies
- Quarterly interior pest control
- Quarterly HVAC filter change and service
- All inclusive base utilities *(subject to limitations)*
 - *water, electricity, natural gas (if applicable)*
- Gated secured truck, trailer and equipment parking
- 24/7 video recorded facilities
- 10pm to 5am “live-eye” video monitoring
- Community forklift for use by all tenants
- AppFolio tenant access software for billing, Tenant service requests, and Landlord communication

AllTrades Unique Property Features

A place where employees want to work and customers want to visit

This product offering is **not found** in the market at equivalent occupancy costs.

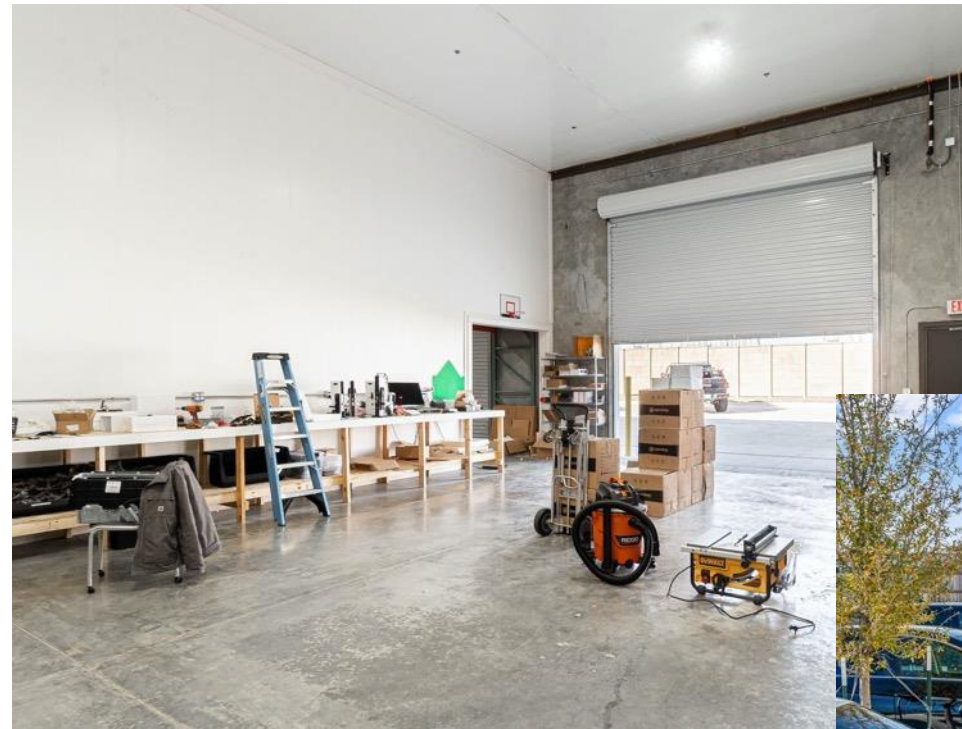

Facility Example – Lewisville, Texas



[Link to virtual tour of Lewisville property](#)



*Redefining space solutions for those who make
the world work.*

Leasing Contact Information:

Leasing Office:

leasing@855AllTrades.com

(855) 255-8723

www.855AllTrades.com