

FOR LEASE

1,681 SF- 4,198 SF Retail Space Available

SMITHS ANCHORED 55-75 S. VALLE VERDE DR.

MILES SANSONE

Phone: (702) 768-1930 (702) 914-9500 x107

Email: [Leasing@SansoneCompanies.com](mailto:Leasing@SansoneCompanies.com)

Corporate Address: 2580 St. Rose Pkwy. Ste. 125 Henderson, Nevada 89074

[www.SansoneCompanies.com](http://www.SansoneCompanies.com)





LEASING DETAILS

SPACE AVAILABLE	1,681 SF- 4,198 SF
LEASE PRICE	\$3.25 PSF
NNN	\$0.64 PSF
TIA	LANDLORD WILL CONTRIBUTE FOR GREASE INTERCEPTOR

PROPERTY HIGHLIGHTS

- Smiths Grocery anchored with strong Tenant Mix
- Located off of I-215
- Affluent area with great demographics
- Huge Open parking field
- National Tenants: Smith's, Mc Donald's, and more!

DEMOGRAPHICS

<u>POPULATION</u>	<u>2-mile</u>	<u>5-mile</u>	<u>10-mile</u>
2023 Population	67,261	311,635	888,486
<u>HOUSEHOLDS</u>	<u>2-mile</u>	<u>5-mile</u>	<u>10-mile</u>
2023 Households	26,879	120,647	343,522
<u>INCOME</u>	<u>2-mile</u>	<u>5-mile</u>	<u>10-mile</u>
2023 Average	\$107,313	96,741	86,848







4,198 SF  
AVAILABLE

1,681 SF  
AVAILABLE

LESIE'S POOL SUPPLIES  
SERVICE & REPAIR

TAN  
REPUBLIC

MATHNASIUM  
The Math Learning Center

AT YOUR SERVICE  
FOR STUDENTS & MORE

Smith's

McDonald's

KOHL'S

INTERSTATE  
215

PASEO VERDE

VALLE VERDE

PEARLE  
CO  
VISION

Southwest  
Medical

TACOTARIAN  
plant-based Mexican eatery

SANSONE  
COMPANIES

55-75 S Valle Verde  
Henderson, NV 89012



55 S. Valle Verde



55-75 S Valle Verde  
Henderson, NV 89012

DEMISABLE

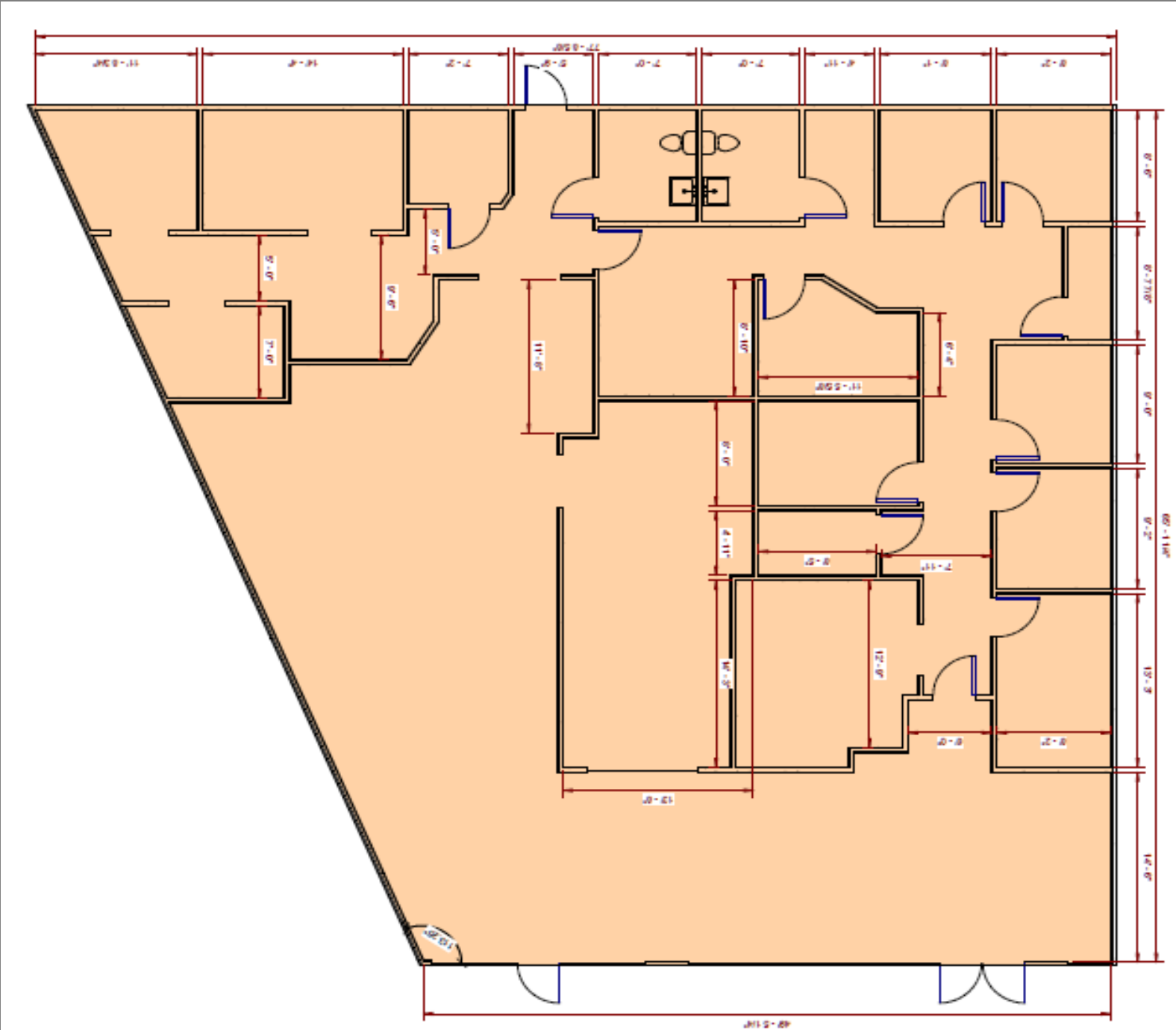

55-75 S Valle Verde  
Henderson, NV 89012

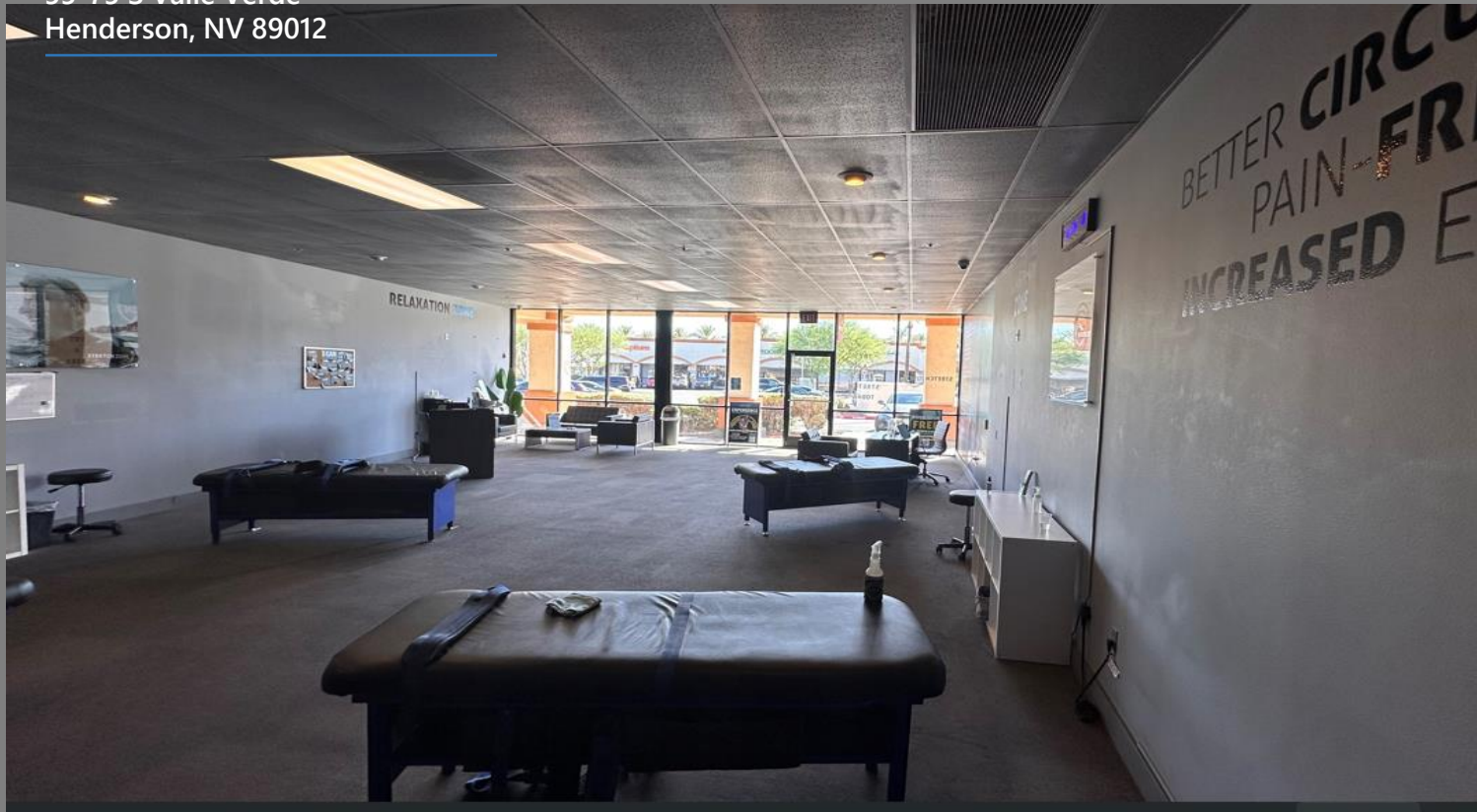



55-75 S Valle Verde  
Henderson, NV 89012

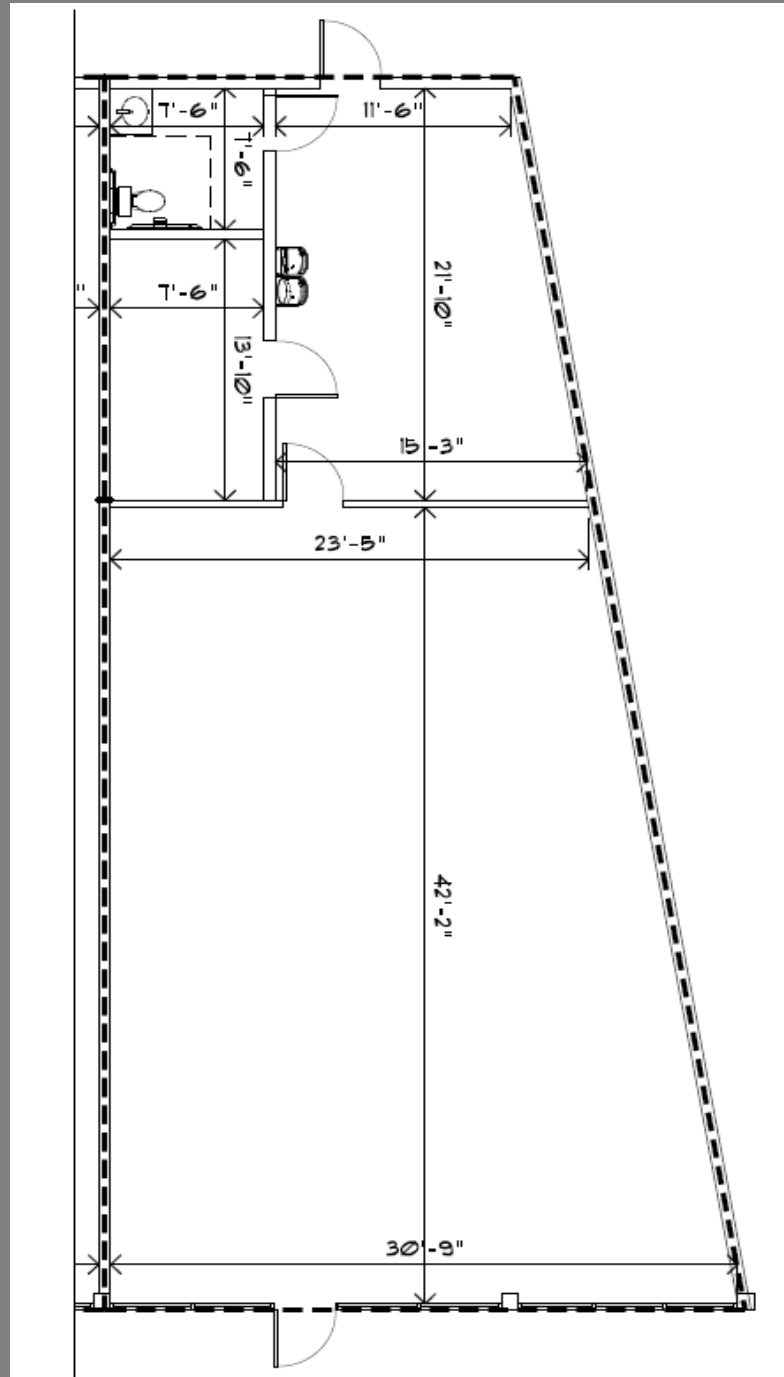

55-75 S Valle Verde  
Henderson, NV 89012

