

RETAIL PROPERTY

# FOR SALE

894 St. Clair Avenue West, Toronto, ON, M6C 1C5



Located in a rapidly developing section of St. Clair Avenue West.

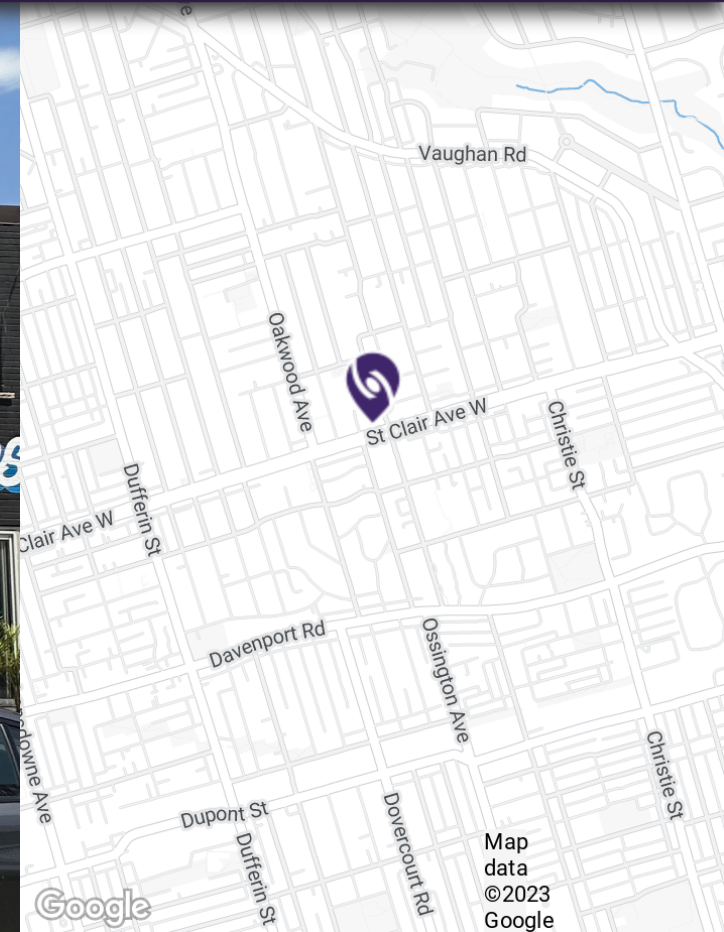

**MICHAEL J. SAPERIA**

Executive Vice President | Broker  
O: 416.636.8898 EXT. 229  
C: 416.804.9162  
msaperia@thebehargroup.com

**DAVID STEINHOUSE**

Senior Director | Sales Representative  
O: 416.636.8898 EXT. 276  
C: 416.418.4653  
dsteinhouse@thebehargroup.com

**AVI BEHAR**

Chairman & Chief Executive Officer | Broker  
416.636.8898 EXT. 227  
abehar@thebehargroup.com

**The Behar Group Realty Inc., Brokerage**

1170 Sheppard Avenue West, Suite 24  
Toronto, ON M3K 2A3  
Tel: 416.636.8898  
Fax: 416.636.8890  
www.TheBeharGroup.com

# PROPERTY DETAILS

## DETAILS

894 St. Clair Ave W

Size	2,986 SF
Sale Price	\$1,699,000
Legal Description	PART LOT 39, PLAN M-427, PARTS 5, 6, 7, 8, 9 AND 10 ON PLAN 66R31440; TOGETHER WITH A RIGHT OF WAY COMMON WITH ALL OTHERS ENTITLED THERETO OVER, ALONG AND UPON THAT PART OF LOT 39, PLAN M-427, DESIGNATED AS PARTS 2, 6, 7 AND 10, PLAN R-3745 AS IN B229190; TOGETHER WITH A FURTHER ROW IN COMMON WITH ALL OTHERS ENTITLED THERETO OVER, ALONG AND UPON THOSE PARTS OF LOTS 38 AND 39, PLAN M-427, DESIGNATED AS PARTS 4, 5, 6, 7 AND 8, PLAN R-3800 AS IN B229190 SUBJECT TO AN EASEMENT AS IN AT5510540 SUBJECT TO AN EASEMENT OVER PARTS 6 AND 9 ON PLAN 66R31440 AS IN LT225224 SUBJECT TO AN EASEMENT OVER PARTS 5, 6 AND 7 ON PLAN 66R31440 AS IN B229190 CITY OF TORONTO
PIN	104740030
ARN	190405366000320
Asset Class	Store + Apartment/Office
Lot Size	Approximately 19.76 x 126 ft.
2023 Final Realty Taxes	\$19,248.01

### Property Highlights

- Vacant ground-floor retail area, vacant second-floor office/apartment, vacant basement, includes a garage and 2 parking spaces.



# FLOOR PLANS

**Floor B1**

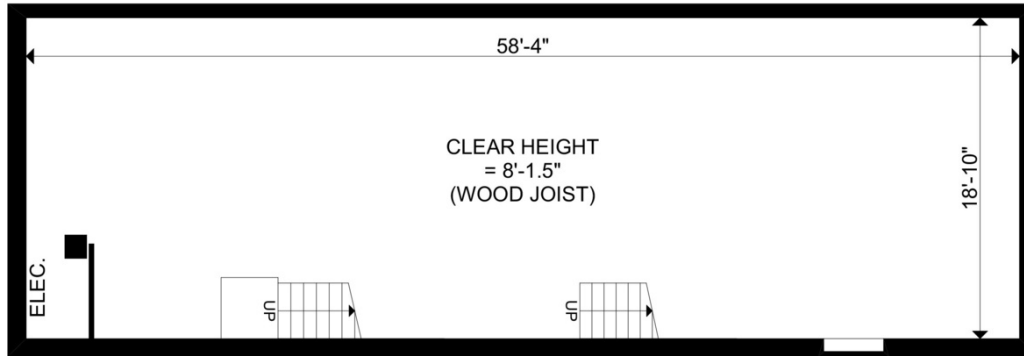

Exterior Gross Area\*

Basement Area:	1,252 sq ft
Floor 01 Area:	1,474 sq ft
Floor 02 Area:	1,512 sq ft
Total EGA:	4,238 sq ft

**Floor 01**

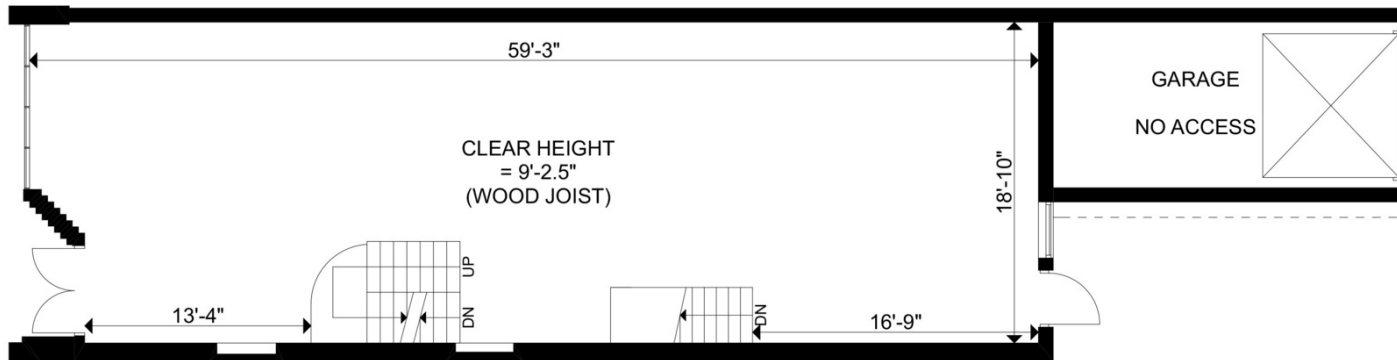

**Floor 02**

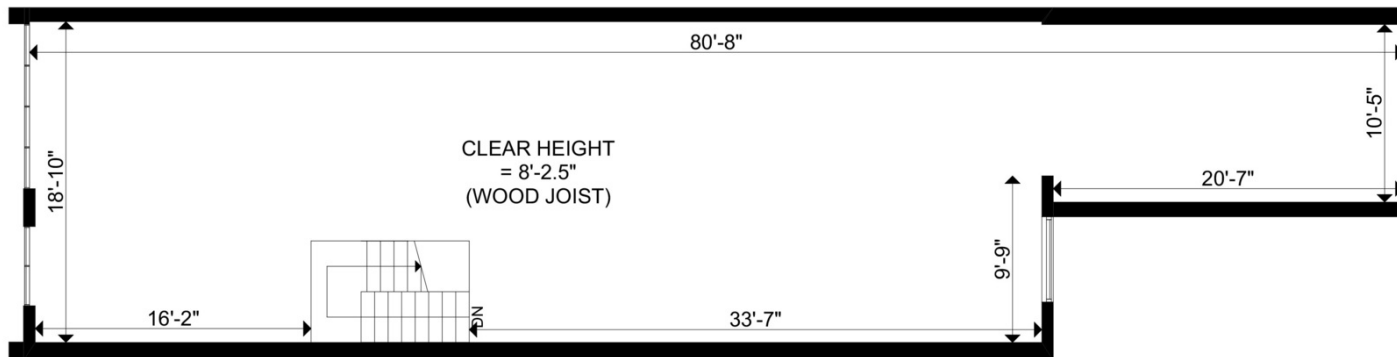

# RETAILER MAP

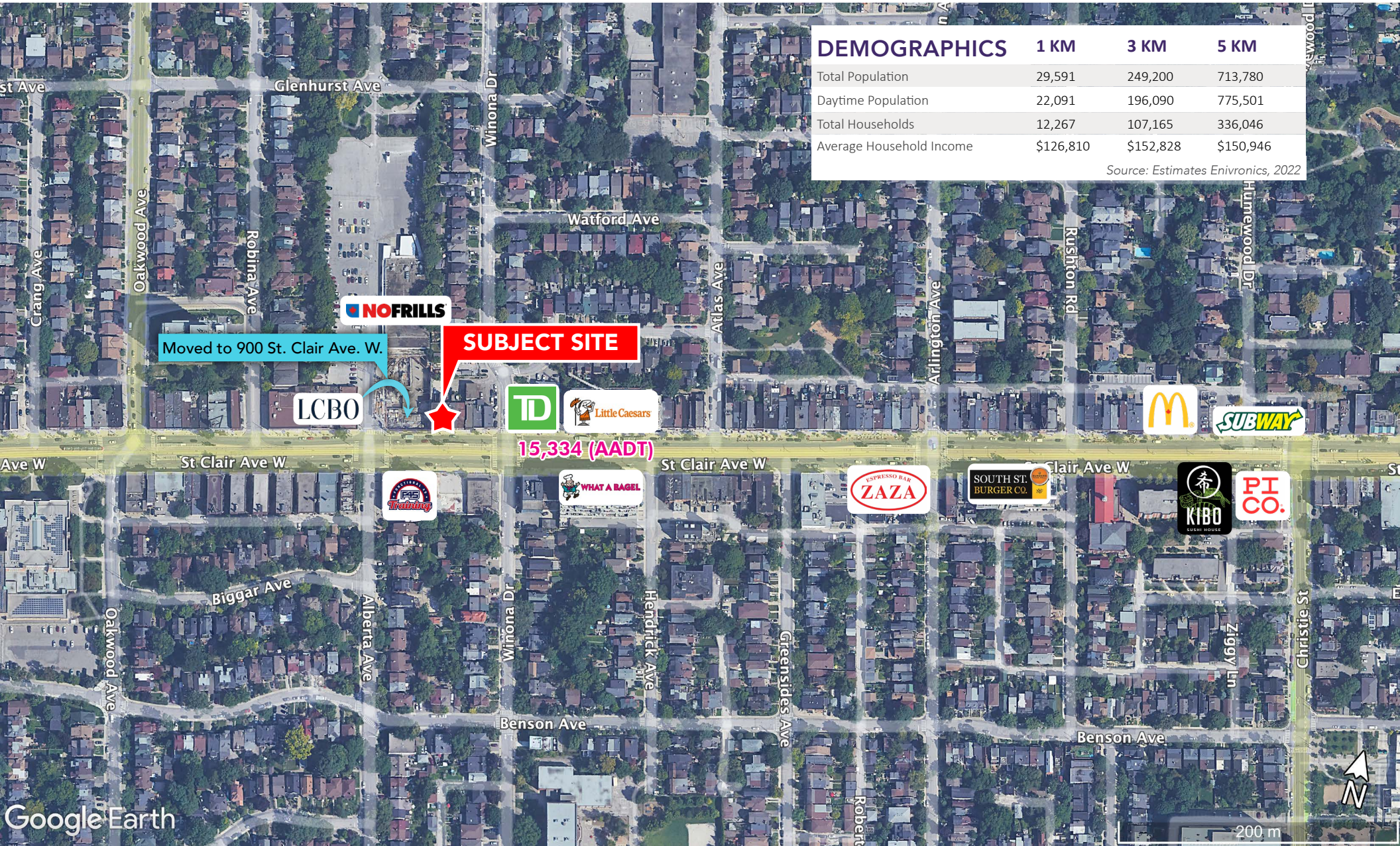

DEMOGRAPHICS	1 KM	3 KM	5 KM
Total Population	29,591	249,200	713,780
Daytime Population	22,091	196,090	775,501
Total Households	12,267	107,165	336,046
Average Household Income	\$126,810	\$152,828	\$150,946

Source: Estimates Enivronics, 2022

15,334 (AADT)



# DEVELOPMENTS MAP

**+/- 605 Units Under Development** *Within Map Extent\**

Sources: City of Toronto & UrbanToronto

	PROJECT/ADDRESS	STATUS	STOREYS	UNITS
1	908 St Clair Ave W	Under Construction	12	173
2	900 St Clair Ave W	Under Construction	12	117
3	863 St Clair Ave W	Under Construction	10	76
4	836 St Clair Ave W	Complete	8	116
5	829 St Clair Ave W	Complete	9	123



# ADDITIONAL PHOTOS



Interior Ground Floor

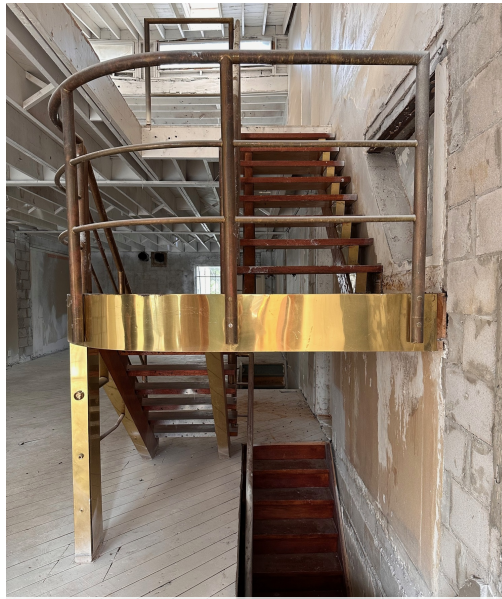

Interior Staircase



Interior Second Floor



Interior Basement



Interior Ground Floor



Interior Staircase



Interior Second Floor



Exterior Rear

# CONTACTS

All listing inquiries should be directed to the Designated Representative(s)

## MICHAEL J. SAPERIA

Executive Vice President | Broker  
O: 416.636.8898 EXT. 229  
C: 416.804.9162  
msaperia@thebehargroup.com

## DAVID STEINHOUSE

Senior Director | Sales Representative  
O: 416.636.8898 EXT. 276  
C: 416.418.4653  
dsteinhouse@thebehargroup.com

## AVI BEHAR

Chairman & Chief Executive Officer | Broker  
416.636.8898 EXT. 227  
abehar@thebehargroup.com



**THE BEHAR GROUP™**  
BROKERAGE & COMMERCIAL  
REAL ESTATE SERVICES

LANDLORD  
SERVICES

TENANT  
SERVICES

CAPITAL  
MARKETS

ADVISORY  
SERVICES

### Head Office (Mailing Address)

1170 Sheppard Avenue West, Suite 24,  
Toronto, ON, M3K 2A3

### Downtown Office

30 Duncan Street, Suite 201  
Toronto, ON, M5V 2A3

The Behar Group Realty Inc., Brokerage

Tel: 416.636.8898 | Fax: 416.636.8890

[www.TheBeharGroup.com](http://www.TheBeharGroup.com)

## DISCLAIMER & DISCLOSURE - IMPORTANT INFORMATION - PLEASE READ

**Brokerage Duties and Representation Disclosure:** The Real Estate Council of Ontario (RECO) regulates real estate professionals in Ontario. RECO's mandate is to protect the public interest by promoting a safe and informed marketplace and administering the rules that real estate agents and brokerages must follow.

As of December 1, 2023, new legislation has come into effect (TRESA -phase 2). These changes affect how you interact with real estate agents and brokerages.

Please read the Information guide published by RECO. Click here: [RECO Information Guide](#)

If you are represented by another Brokerage under a Tenant or Buyer Representation Agreement (Brokerage or Designated), please have your Designated Representative contact us on your behalf. This marketing material is not intended to solicit clients who are represented by another brokerage or Designated Representative. If you are not represented by another brokerage or another Designated Representative, and wish to hire brokerage representation, please contact us for details on our Landlord, Tenant, Advisory and Capital Markets Services.

This property is a Listing of The Behar Group Realty Inc. ("TBG") and the Designated Representative(s) named on these materials. The Landlord/Seller is our client to whom the Designated Representative(s) owes Fiduciary Duties.

Unless you are also a Client of TBG (and you consent to Multiple Representation), then you are a Self Represented Party (SRP). It is important that you understand and acknowledge the risks and role as a SRP. Please read the RECO Information Guide, and before asking for assistance from the Designated Representative listed on this flyer be prepared to sign and acknowledge the RECO Information and Disclosure form for Self Represented Parties: [Click Here.](#)

TBG strongly recommends that consumers retain the services of a qualified and experienced real estate agent.

For all transactions completed with TBG, you will be required to sign a Confirmation of Cooperation and Representation Agreement, whether you are a SRP or not, to ensure acknowledgement of representation disclosure.

**Photo/Renderings Disclosure:** Any photos used in these materials may have been digitally manipulated for illustrative purposes, and the actual property's appearance may differ; please verify details independently. Any property renderings used are artistic concepts only and may not reflect the final build of the project.

**Errors and Omissions Disclosure:** All information is from sources deemed reliable and is subject to errors and omissions which we believe to be correct and assume no responsibility. Changes in respect of price, rental, prior sale and withdrawal may be changed without notice. None of the information contained herein is intended to be construed as legal or tax or other professional advice. You should consult your legal counsel, accountant, planner/architect/engineer or other advisors as necessary on matters relating to these materials.