



NEW TO MARKET RETAIL FOR LEASE

CAROLINE RALSTON CREEK

Kipling St. and 58th Ave.
Arvada, CO 80002

NAI Shames Makovsky

RETAIL LEASING:

Robert A. Hudgins

303 565 3033

Cory Dulberg
303 565 3039
cdulberg@shamesmakovsky.com

rhudgins@shamesmakovsky.com

DEVELOPMENT
BY



CAROLINE RALSTON CREEK

New to market retail in vibrant Arvada submarket

- Suites ranging from 1,466 to 5,565 SF
- Dedicated retail surface parking
- Strong visibility on 58th Avenue
- Street level retail in new residential multifamily project

Project Overview

Commercial Leasable Area	10,000 SF
Land Area	8.4 AC
Construction Start	Under Construction
Residential Units	328
Residential First Occupancy	April 2024





ktgy

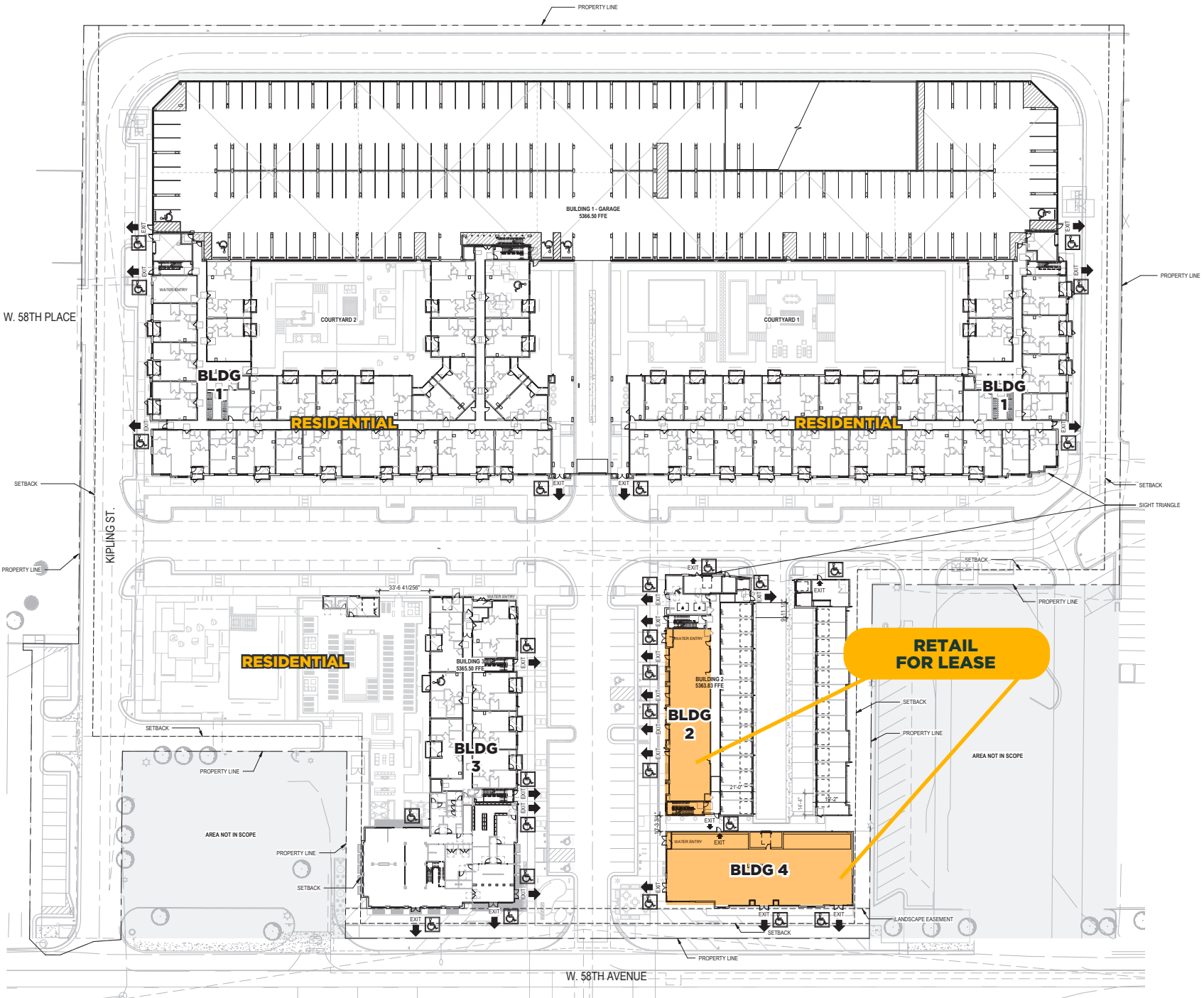

RETAIL FOR LEASE CAROLINE RALSTON CREEK



BUILDING 2

BUILDING 4

LOFTS ON KIPLING

SHOPS

SHOPS

SHOPS

SHOPS

58TH AVENUE (21,939 VPD)



BUILDING 2 RETAIL

TWO TENANT OPTION

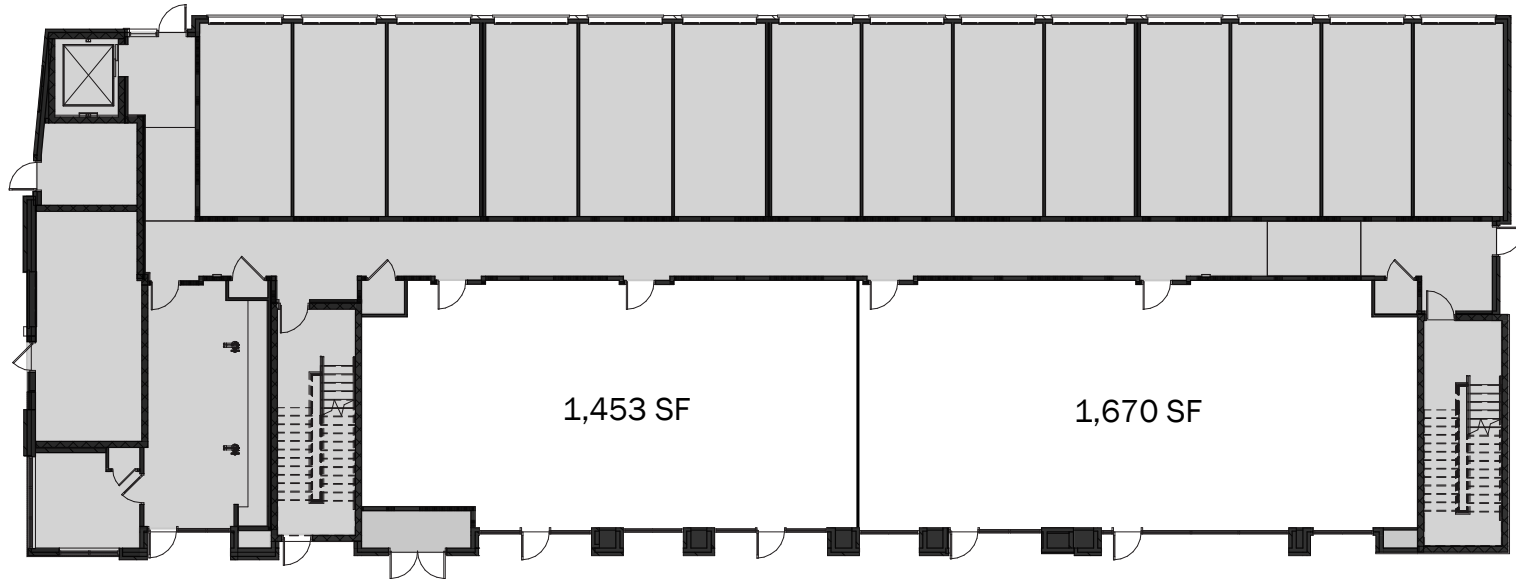

THREE TENANT OPTION

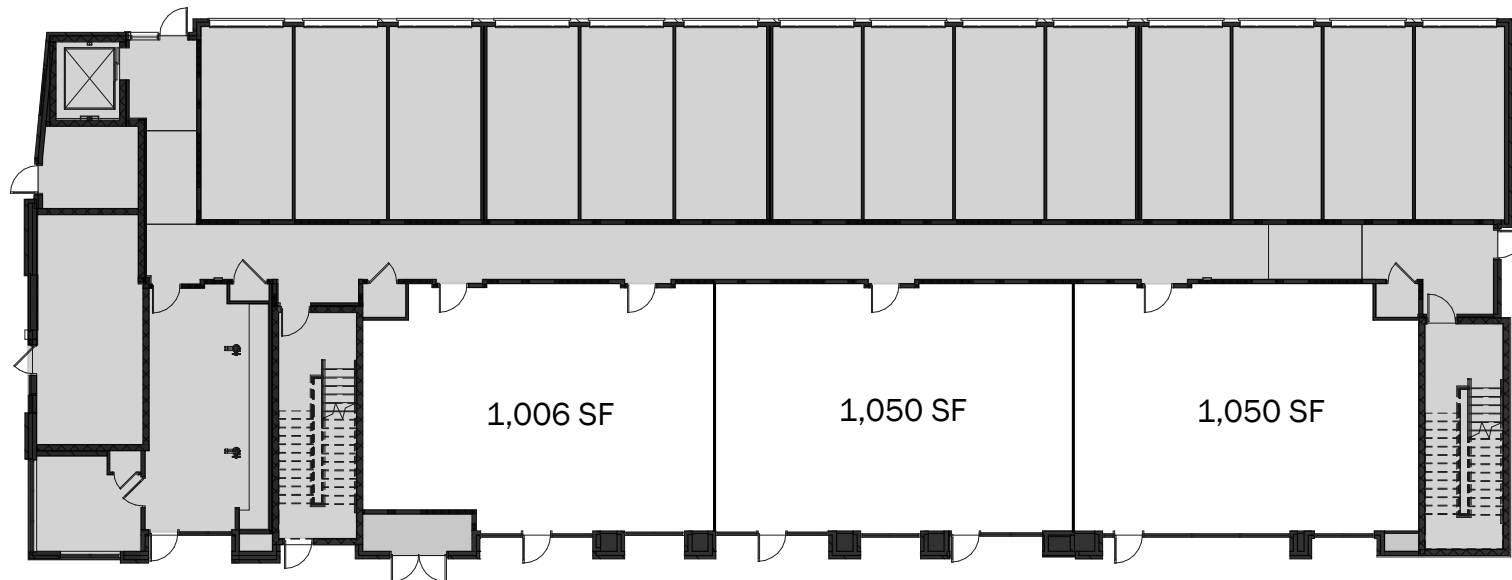

BUILDING 4 RETAIL

THREE TENANT OPTION

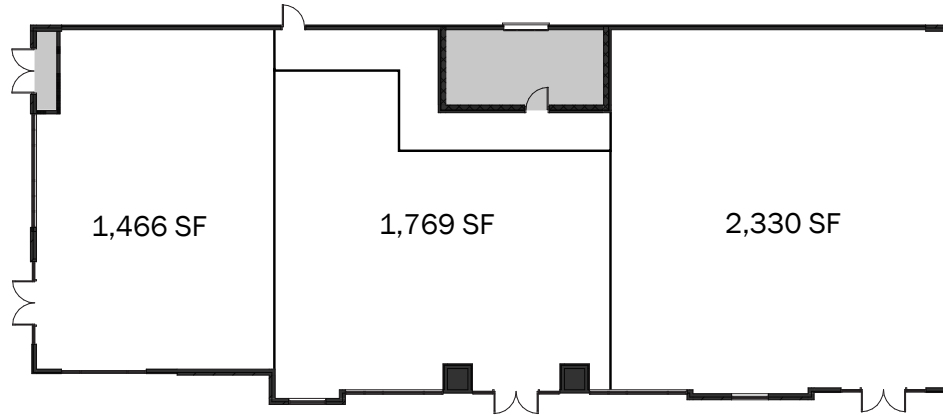

TWO TENANT OPTION

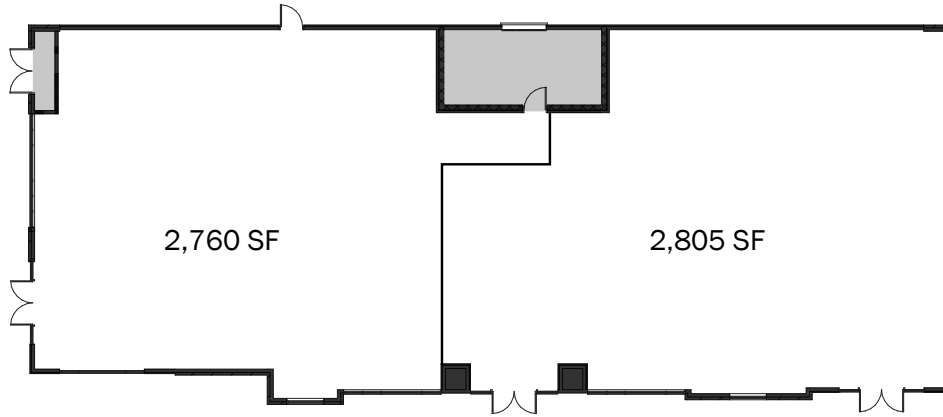

SINGLE TENANT OPTION

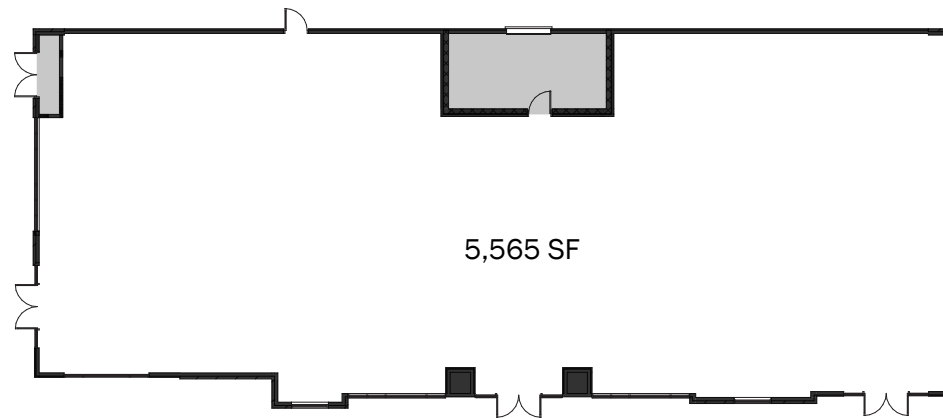

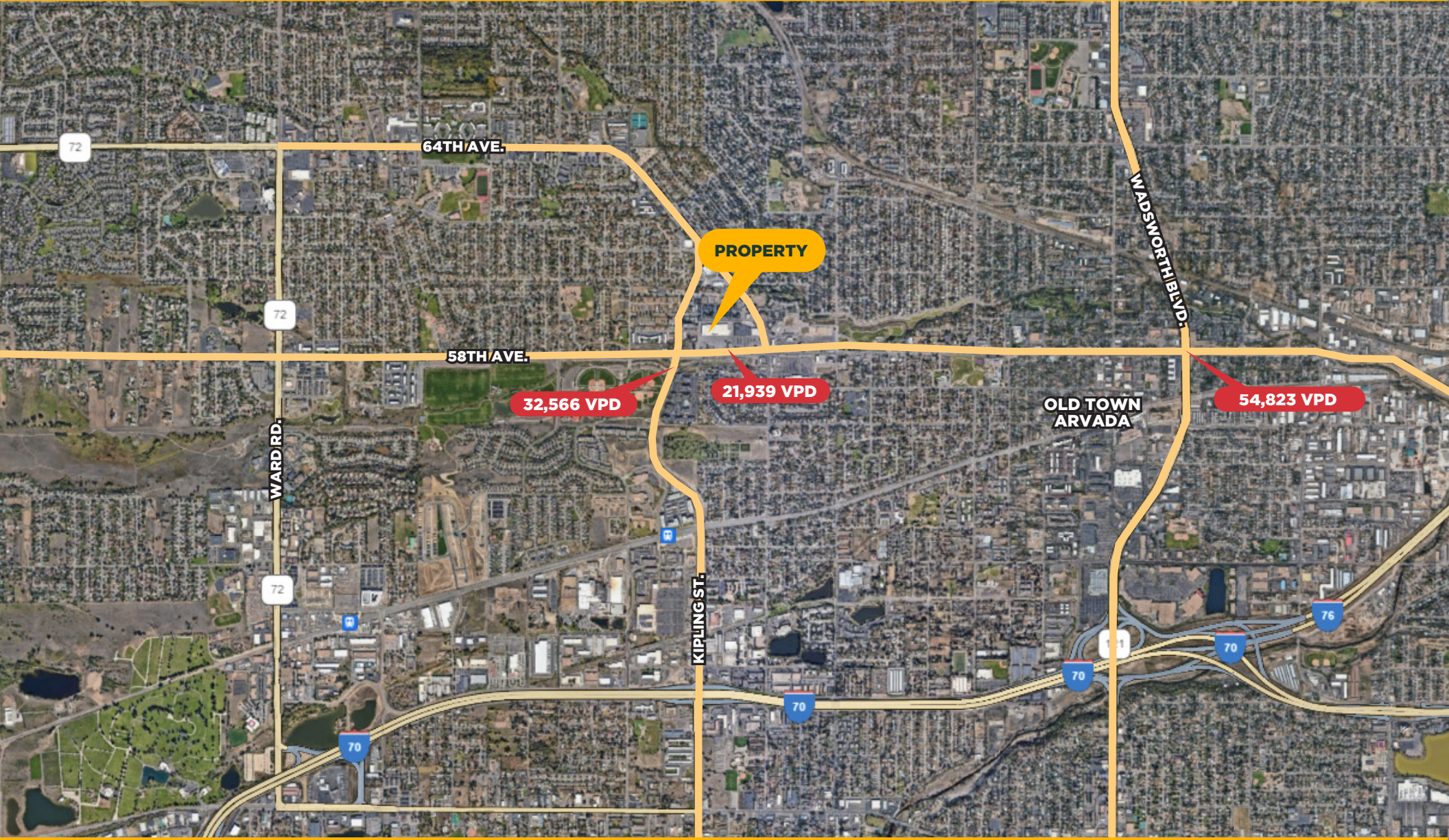

NEARBY DEVELOPMENT



RALSTON CREEK TOWNHOMES

- 47 for sale townhomes
- Completed by 2023
- Estimated cost \$15,000,000



RALSTON COMMONS

- 185 apartments
- 27 for sale townhomes
- 5,500 SF of retail
- Completed by 2024
- Estimated cost \$73,500,000



RALSTON GARDENS

- 102 affordable units
- Completed by 2023
- Estimated cost \$38,000,000

ARVADA, CO

Nearby Olde Town Arvada (1 Mile to the East) is the heart and soul of the City.

Downtown Arvada is where historic roots intermingle with new and fresh ideas providing a one of a kind authentic experience in a relaxed atmosphere. With a diverse array of shops, boutiques, galleries, events, restaurants, breweries and a winery, Olde Town has all of the amenities of a thriving urban hub set within a turn-of-the-century Main Street Americana ambiance.



AREA DEMOGRAPHICS

	1 MI	3 MI	5 MI
DAYTIME POPULATION	15,342	102,873	294,297
POPULATION	18,460	106,788	289,496
MEDIAN HOUSEHOLD INCOME	\$69,955	\$92,158	\$96,138
TRAFFIC	Kipling Street at 58th: 24,741 VPD 58th Ave. at Kipling Street: 20,996 VPD		



CAROLINE RALSTON CREEK

Kipling St. and 58th Ave.
Arvada, CO 80002

NAI Shames Makovsky

Cory Dulberg
303 565 3039

cdulberg@shamesmakovsky.com

Robert A. Hudgins
303 565 3033

rhudgins@shamesmakovsky.com

DEVELOPMENT
BY

