

welltower

MEDICAL OFFICE SPACE
FOR LEASE

Click or Scan Below



For Information:

GARRETT BENEFIEL
Regional Director, Leasing
251.680.8989
gbenefiel@welltower.com

Mt. Vernon Medical Center

755 MOUNT VERNON HIGHWAY | ATLANTA, GA

medicaloffice.welltower.com

EXECUTIVE SUMMARY



Location Description

Located 1.5 miles from Pill Hill, where the campuses of both Northside Hospital Atlanta and Emory Saint Joseph's Hospital are situated.

Property Highlights

- Class "A" medical office building containing a mix of primary care and specialist practices
- Active referral patterns among tenants
- On-site property management
- Competitive lease rates and generous tenant improvement allowances



GARRETT BENEFIEL
Regional Director, Leasing
251.680.8989
gbenefiel@welltower.com

FLOOR PLANS

welltower

360°
CLICK TO VIEW TOUR

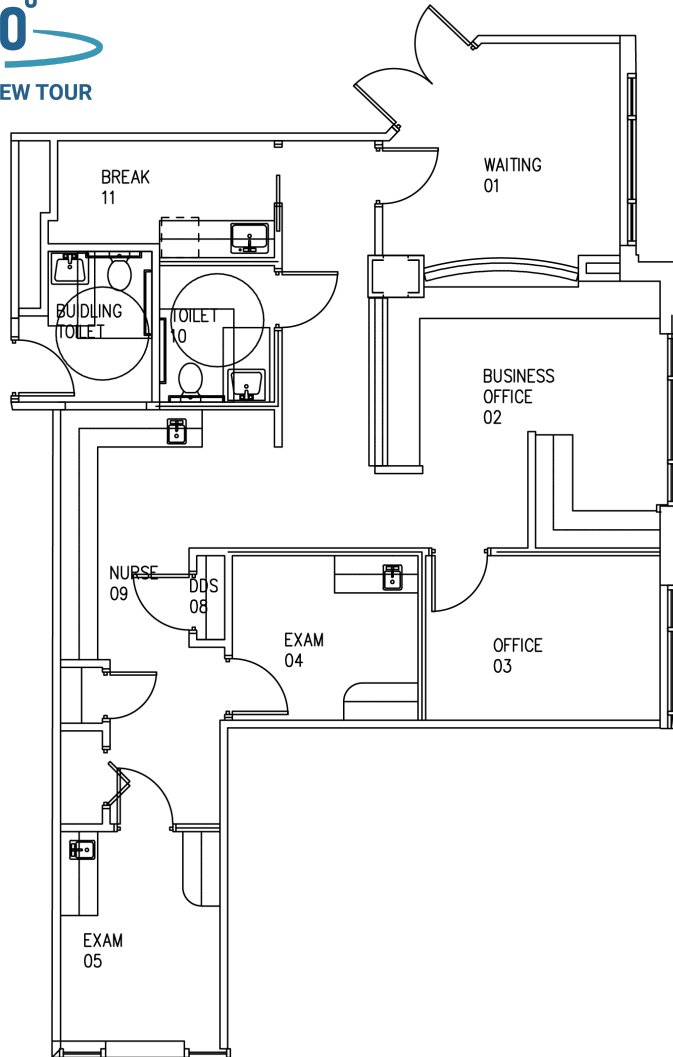

120

1,353 RSF

GARRETT BENEFIEL
Regional Director, Leasing
251.680.8989
gbenefiel@welltower.com

360°
CLICK TO VIEW TOUR

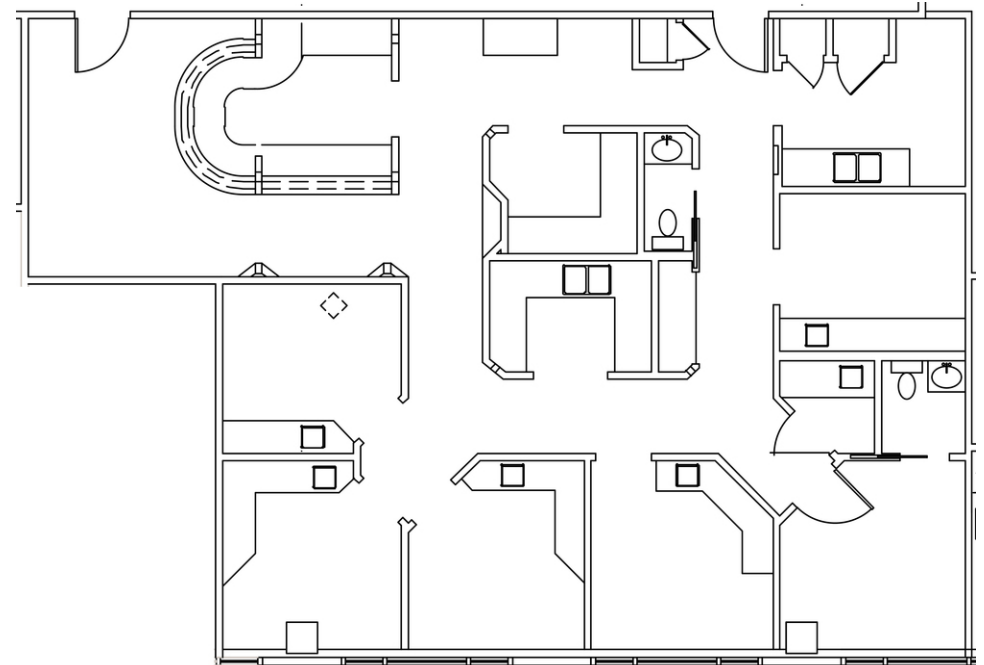

140

1,797 RSF



FLOOR PLANS

welltower

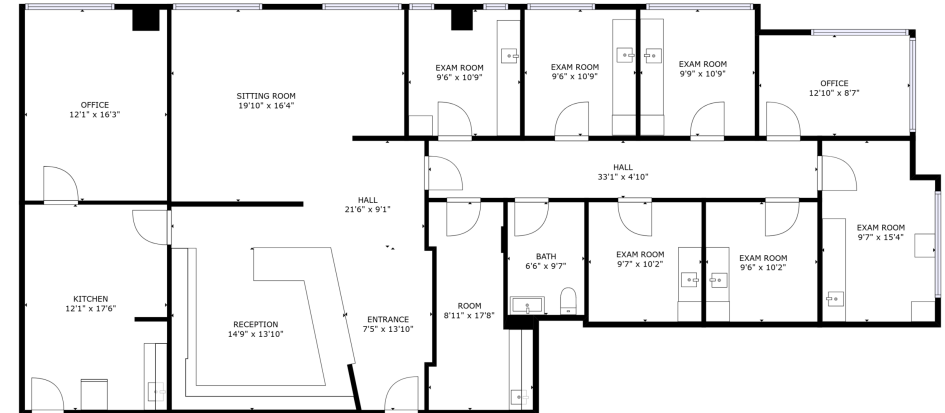
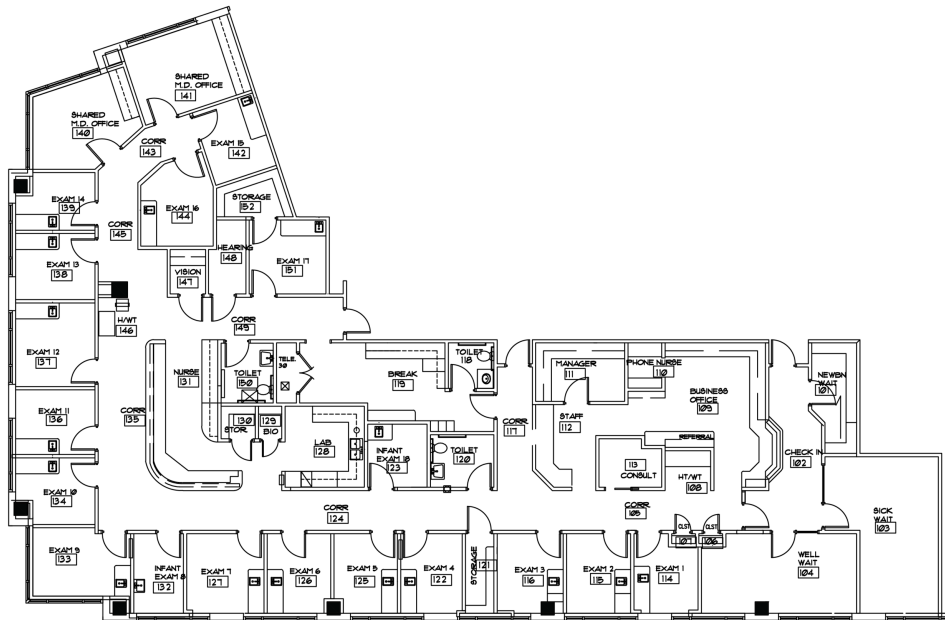

150

5,932 RSF

GARRETT BENEFIEL
Regional Director, Leasing
251.680.8989
gbenefiel@welltower.com

350

2,807 RSF

FLOOR PLANS

welltower

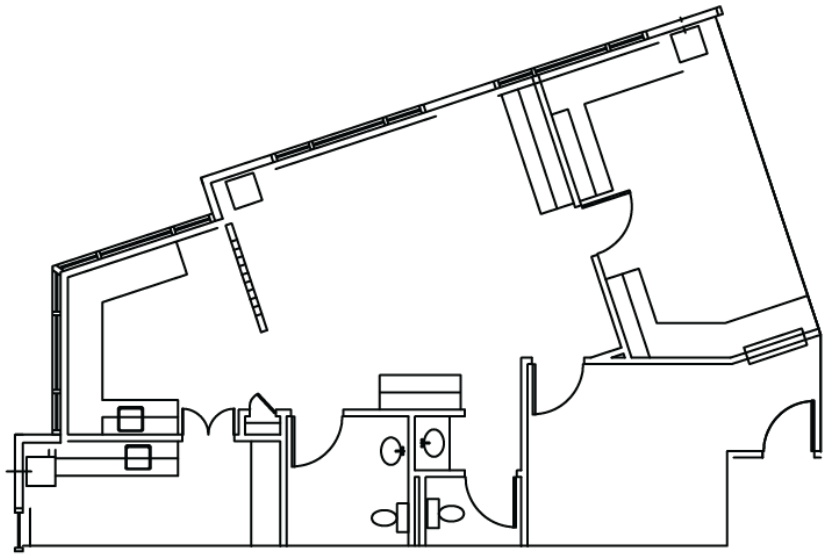
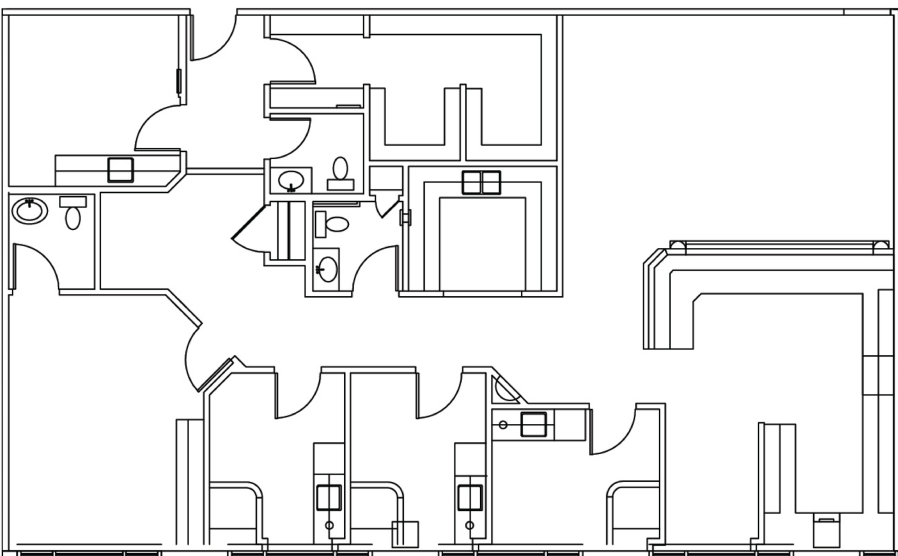

420

2,288 RSF

GARRETT BENEFIEL
Regional Director, Leasing
251.680.8989
gbenefiel@welltower.com

450

1,218 RSF



DEMOGRAPHICS MAP & REPORT



Population	1 Mile	3 Miles	5 Miles
Total Population	7,617	84,491	200,792
Average Age	41.5	36.5	37.4
Average Age (Male)	38.1	36.5	37.2
Average Age (Female)	43.6	36.8	37.7

Households & Income	1 Mile	3 Miles	5 Miles
Total Households	4,173	39,571	89,021
# of Persons per HH	1.8	2.1	2.3
Average HH Income	\$91,065	\$105,012	\$116,182
Average House Value	\$363,030	\$420,054	\$465,051

* Demographic data derived from 2020 ACS - US Census

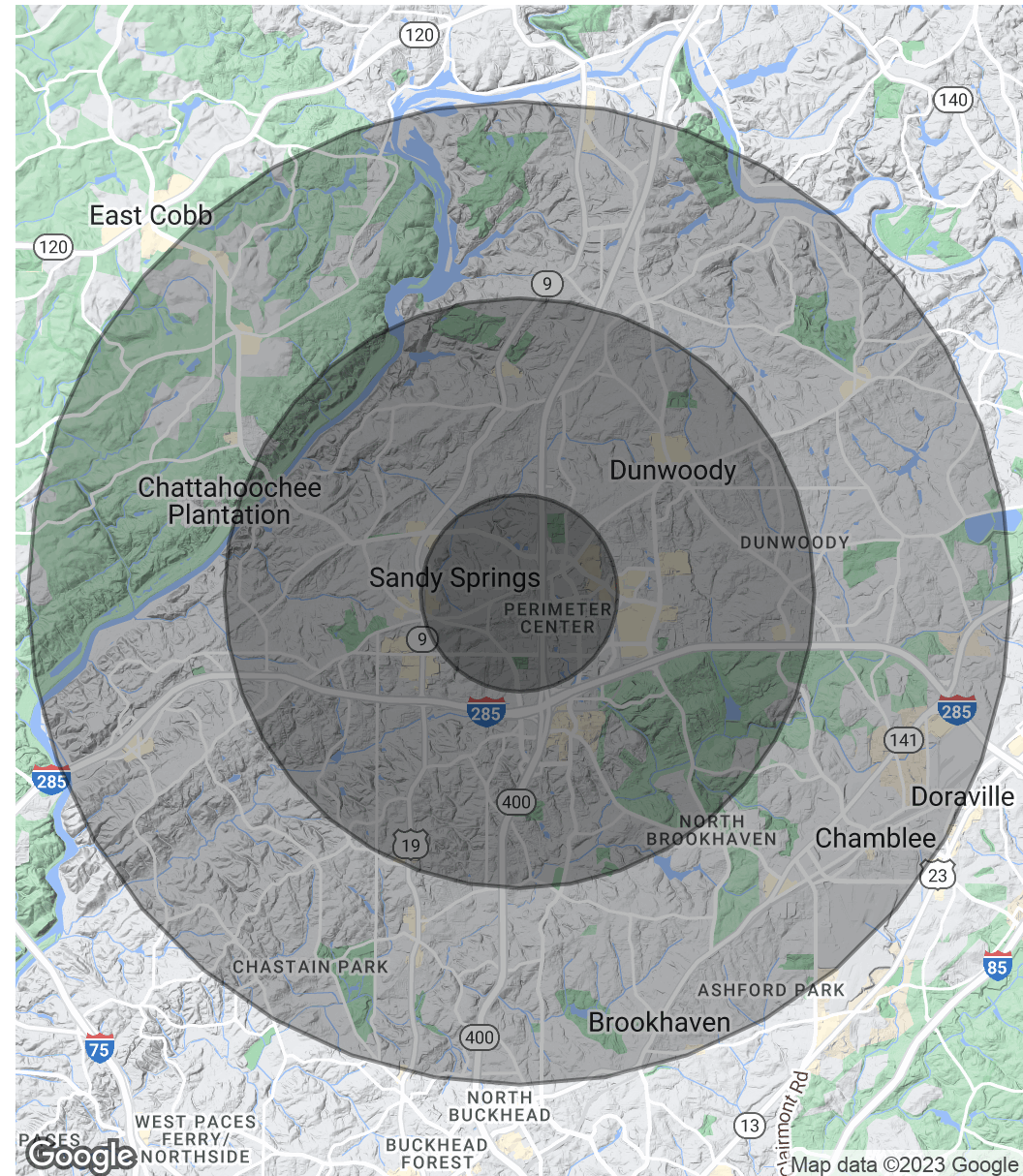

GARRETT BENEFIEL
 Regional Director, Leasing
 251.680.8989
 gbenefiel@welltower.com