

±4,935 SF Industrial Building  
Available For Lease



1230 DODSON WAY

RIVERSIDE, CALIFORNIA 92507



**1230 DODSON WAY**  
Riverside, CA 92507

**±4,935 SF Industrial Building**  
**Available For Lease**

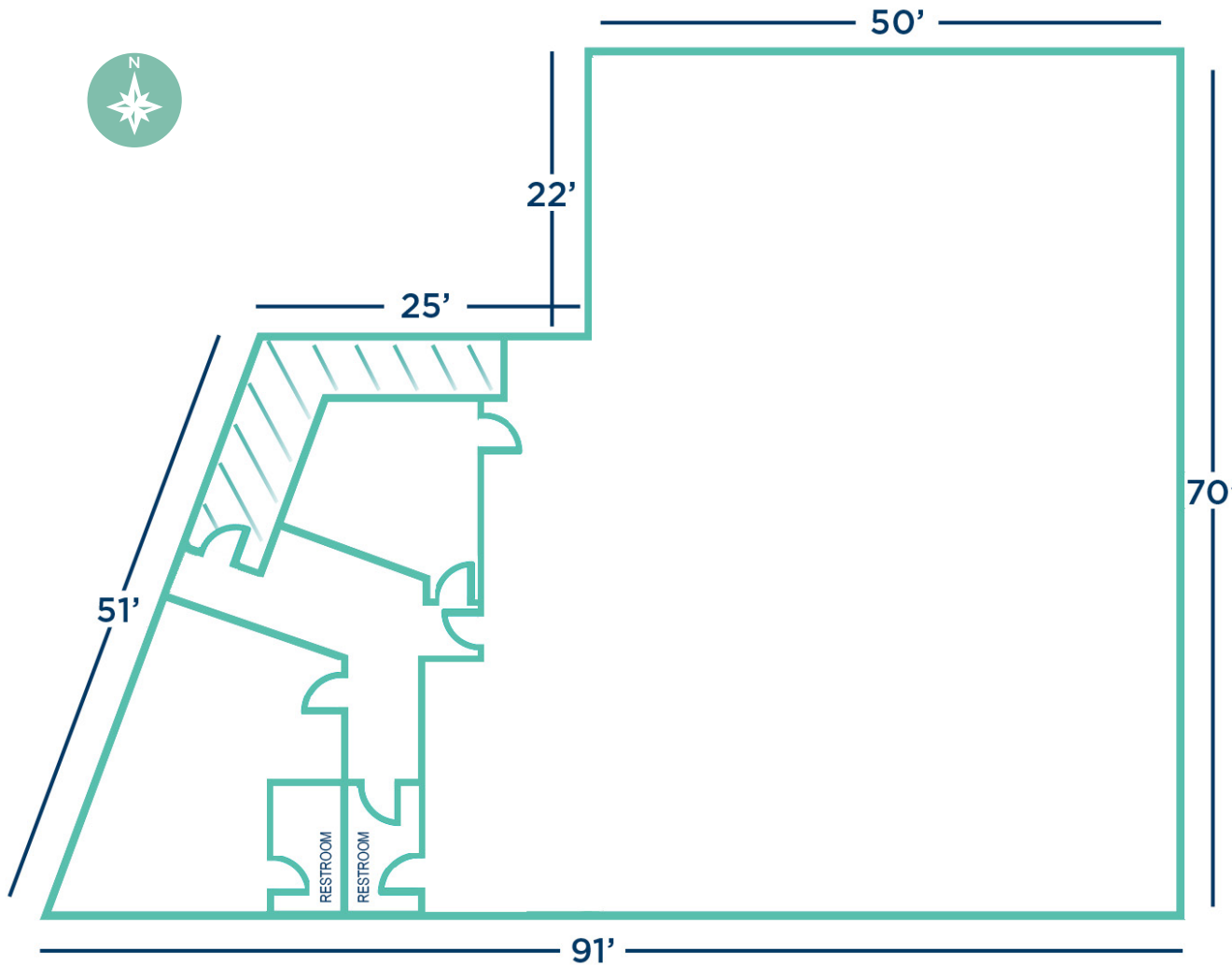

## BUILDING FEATURES

- ±4,935 SF industrial building
- ±1,000 SF office space
- 14' minimum clearance
- One (1) 12' x 12' GL door
- LED Warehouse lighting
- 200 Amps of 120/208 Power (verify)
- New roof, insulation and skylights
- I Zoning (Industrial)
- Bonus mezzanine in office area
- Functional and flexible layout
- Industrial-zoned & business-ready

For more information,  
please contact:

**MILO LIPSON**  
+1 909 942 4648  
milo.lipson@cushwake.com  
CA License #01253614



**1230 DODSON WAY**  
Riverside, CA 92507

**±4,935 SF Industrial Building**  
**Available For Lease**



**IDEAL  
FOR:**

**LIGHT  
MANUFACTURING  
OR ASSEMBLY**

**SMALL-SCALE  
LOGISTICS &  
FULFILLMENT**

**STORAGE + SHOP  
+ OFFICE SPACE**

**WAREHOUSE /  
DISTRIBUTION**

**CONTRACTORS OR  
SERVICE FIRMS**

**REGIONAL SOCIAL  
CONNECTIVITY**

For more information,  
please contact:

**MILO LIPSON**  
+1 909 942 4648  
milo.lipson@cushwake.com  
CA License #01253614



**CUSHMAN &  
WAKEFIELD**

**1230 DODSON WAY**  
Riverside, CA 92507

**±4,935 SF Industrial Building**  
**Available For Lease**



## SUPERIOR ACCESS

- Direct and immediate access to Interstate 215 (I-215), offering quick north-south connectivity.
- Convenient reach to Interstate 60 (I-60) and State Route 91 (SR-91)
- Close to nearby retail, services, and commercial centers

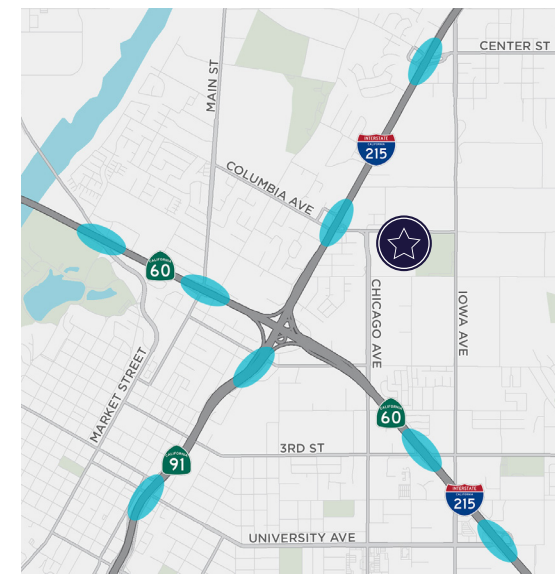

For more information,  
please contact:

**MILO LIPSON**  
+1 909 942 4648  
milo.lipson@cushwake.com  
CA License #01253614

