



FOR LEASE

4736 50TH STREET, RED DEER, AB



LOCATION

Downtown Red Deer



LEGAL DESCRIPTION

Plan 8922183, Block 37, Lot 3A



LEASE RATE

Starting at \$6.00 PSF
NNN: \$6.10 PSF *(includes utilities)*



BUILDING SIZE

300 SF - 2,799 SF



ZONING

C1 - Commercial (City Centre) District



MONTHLY RENT

\$453 - \$2,888 + GST

PROPERTY DETAILS

Various unit sizes available in the Ross Street Centre, located right on 50th (Ross) Street, a major arterial road. Ample parking available with options for on-site and street front parking. Signage available on the south side of the building.

Building consists of a Main Floor, Second Floor and Lower Level with spaces ranging from 300 SF - 2,799 SF, suitable for a variety of uses. Units feature an open layout, with most of units recently renovated. Immediate possession is available.



Main Level (4734 50th Street)



LEASE RATE

Base Rent: \$12.00 PSF
NNN: \$6.10 PSF



MONTHLY RENT

\$3,167.50 + GST



RENTABLE AREA

2,100 SF



POSSESSION

Immediately

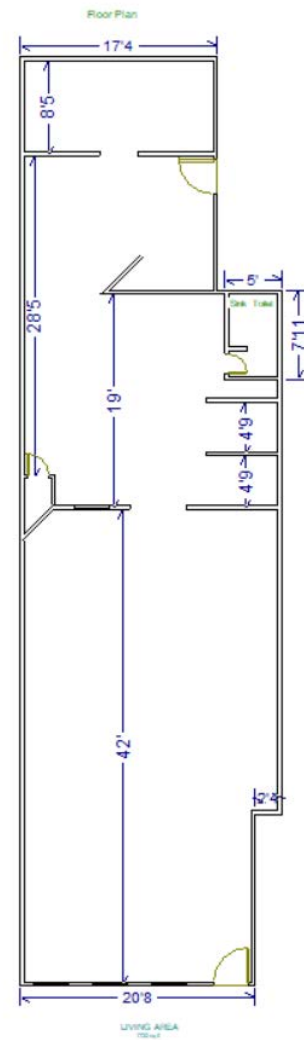

Second Floor (4734 50th Street)

Unit Number	Size (SF)	Lease Rate (PSF)	CAM & Taxes (PSF)	Monthly Rent	Possession
201	600	-	-	-	Leased
202*	554	\$11.00	\$6.10	\$789 + GST	Immediate
203	479	\$11.00	\$6.10	\$683 + GST	Immediate
204*	338	\$12.00	\$6.10	\$510 + GST	Immediate
207	745	-	-	-	Leased
208	300	\$12.00	\$6.10	\$453 + GST	Immediate

*Unit 204: Can combine with Unit 202

FLOOR PLAN



Second Floor



UNIT 202



UNIT 204

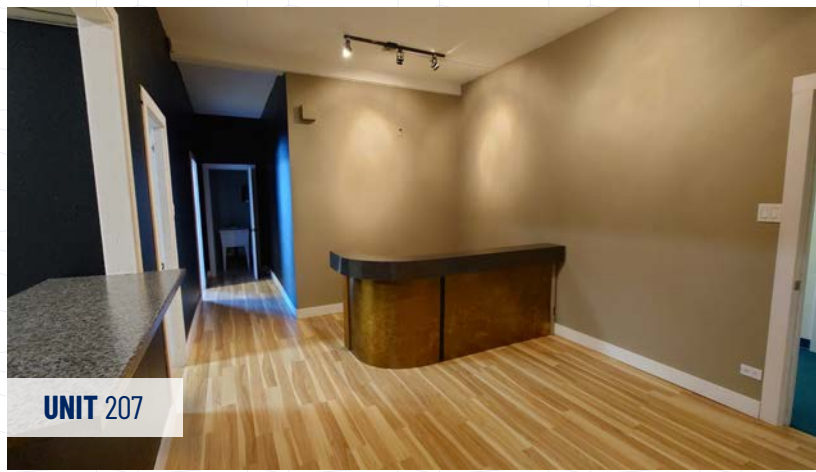

UNIT 207



UNIT 207



UNIT 207

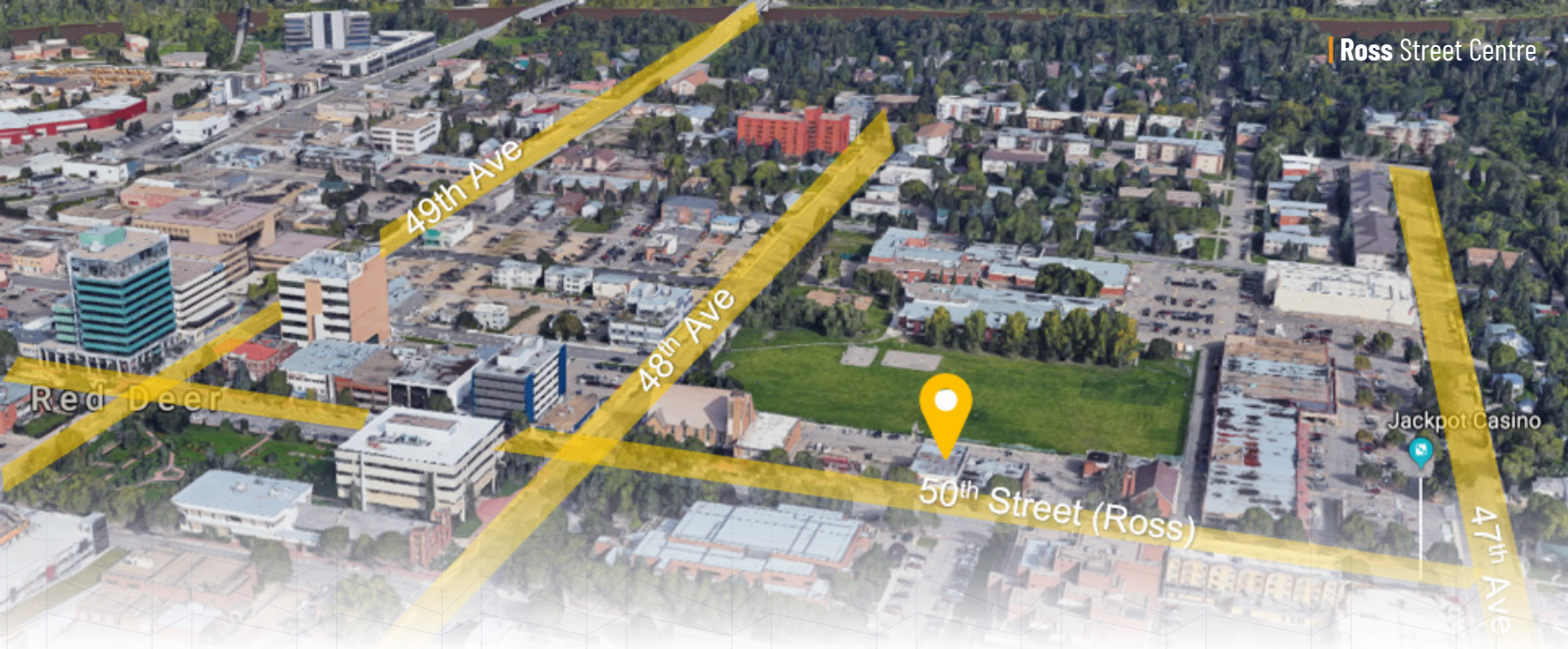

Lower Level (4732 50th Street)



LEASE RATE

Base Rent: \$6.00 PSF
NNN: \$6.10 PSF



MONTHLY RENT

\$2,822.33 + GST



RENTABLE AREA

2,799 SF



POSSESSION

Immediately

FEATURES

- > Reception Area
- > Front and Back Entrances
- > Large Open Area
- > (2) Offices
- > Storage Rooms
- > Washrooms



Central Alberta's Ambassador for Commercial Real Estate



#103, 4315 - 55 Avenue Red Deer, AB T4N 4N7
www.salomonscommercial.com

Davin Kemshead
 Listing Agent
 403.314.6190
davin@salomonscommercial.com

Kelly Babcock
 Broker/Partner
 403.314.6188
kelly@salomonscommercial.com

Brett Salomons
 Partner
 403.314.6187
brett@salomonscommercial.com

Mike Williamson
 Associate
 403.314.6189
mike@salomonscommercial.com

Max Field
 Associate
 403.314.6186
max@salomonscommercial.com

Jordan Krulicki
 Associate
 403.314.6185
jordan@salomonscommercial.com