

Office For Lease



53842 Generations Dr.

South Bend, IN, 46635

Highlights

- **Available Space:** 3,553 SF office suite within a 6,760 SF professional office building
- **Prime Location:** Prime northeast South Bend location in the Foundation Center Office Park near SR 23 & Douglas Road
- **Ideal Layout:** Combination of private offices, open work areas, conference room, and kitchenette – ideal for professional or medical users
- **Additional Features:** Ample on-site parking, signage opportunity, private entrance, and professional curb appeal in a well-maintained brick building

Lease Rate	\$13.25 (NN)
Leasable	3,553 SF
Building Size (SF)	6,760 SF
Zoning	B
Traffic Count	ADT 21,737 (SR 23)

Estimated Expenses

CAM	\$2.75/SF
Electric	\$2,9000/YR
Gas	\$800/YR

Gage Hudak, CCIM
ghudak@bradleyco.com
c 574.855.5706

John Jessen
jjessen@bradleyco.com
c 574.968.9270

Rebecca Ward
rward@bradleyco.com
c 574.855.5718

www.bradleyco.com

Plans

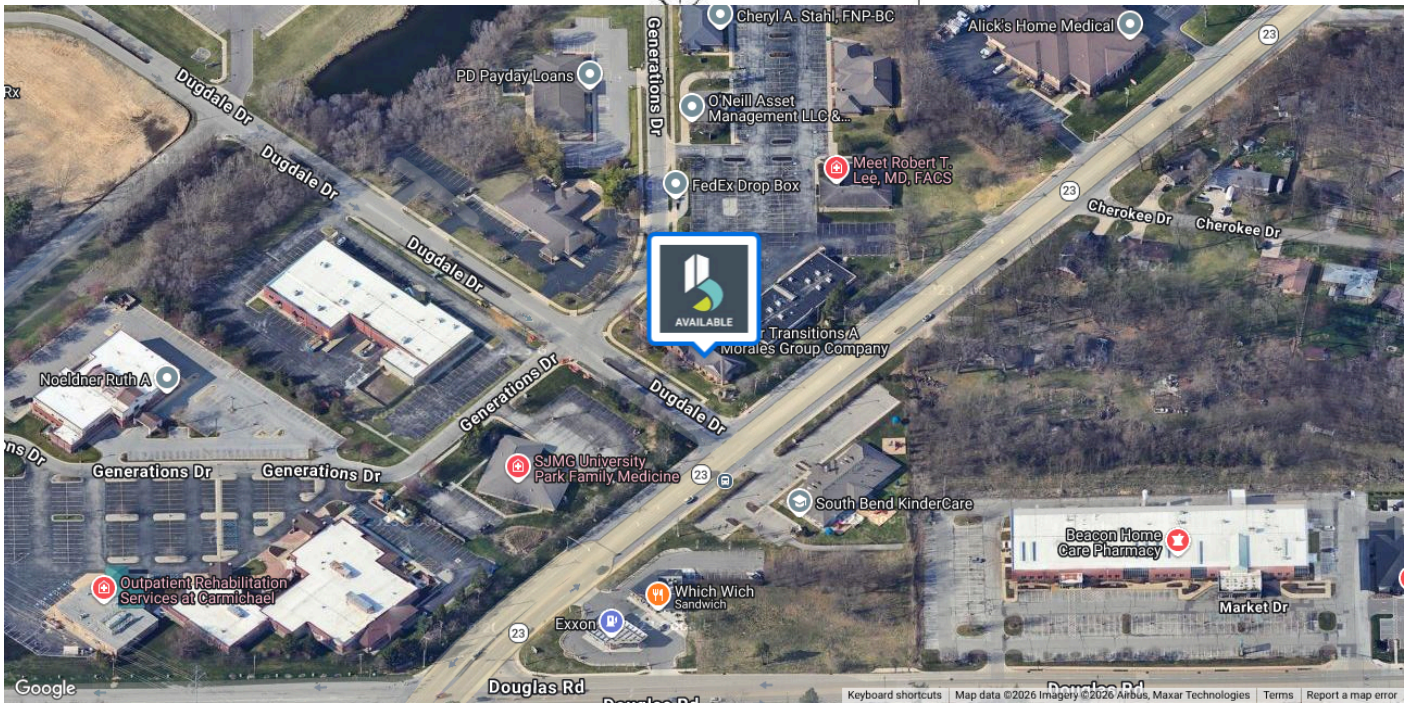
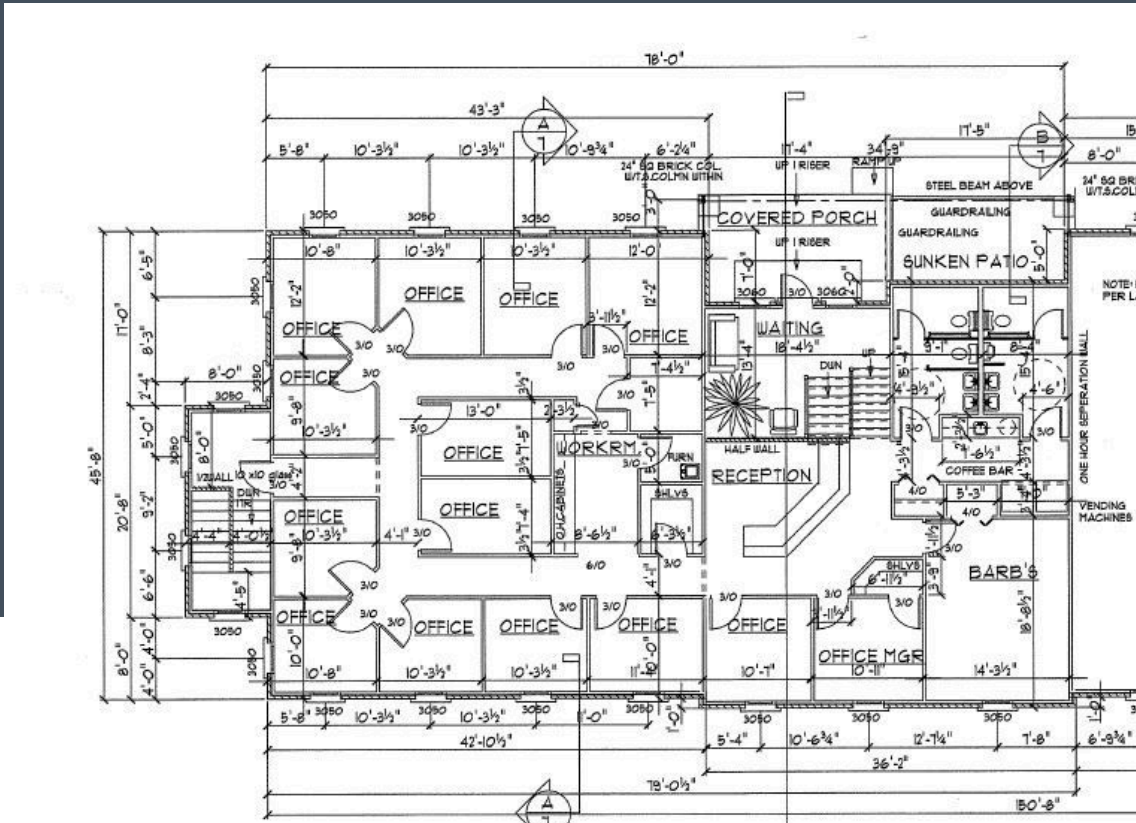

Photos

53842 Generations Dr., South Bend, IN 46635



Retailer Map



Demographics	1 Mile	3 Miles	5 Miles
Total Households	3,238	25,456	62,502
Total Population	5,590	65,418	167,316
Average HH Income	\$60,789	\$59,442	\$57,956

Map data ©2025 Google Imagery ©2025 Airbus, Landsat / Copernicus, Maxar Technologies