

FOR LEASE

INGRAM PARK PLAZA
6161 NW LOOP 410
SAN ANTONIO, TX 78238

**28,638 SF
AVAILABLE**



SHAWN ACKERMAN
President
(713) 386-1088 Direct
shawnackerman@henrysmiller.com

HENRY S. MILLER BROKERAGE | HOUSTON
900 Threadneedle St, Suite 120
Houston, Texas 77079
www.henrysmiller.com

PROPERTY HIGHLIGHTS

INGRAM PARK PLAZA
 6161 NW LOOP 410
 SAN ANTONIO, TX 78238

HIGHLIGHTS

- 28,638 SF Big Box Available For Lease
- Available June 2025
- Former Texas Western Warehouse
- Call Broker For Pricing

AREA RETAILERS



Demographics

1 Mile

3 Mile

5 Mile

Population

13,789

115,584

358,882

Average

HH Income

\$67,298

\$67,974

\$67,803



SHAWN ACKERMAN
 President
 (713) 386-1088 Direct
 shawnackerman@henrysmiller.com

HENRY S. MILLER BROKERAGE | HOUSTON
 900 Threadneedle St, Suite 120
 Houston, Texas 77079
 www.henrysmiller.com

FLOOR PLAN

INGRAM PARK PLAZA
6161 NW LOOP 410
SAN ANTONIO, TX 78238

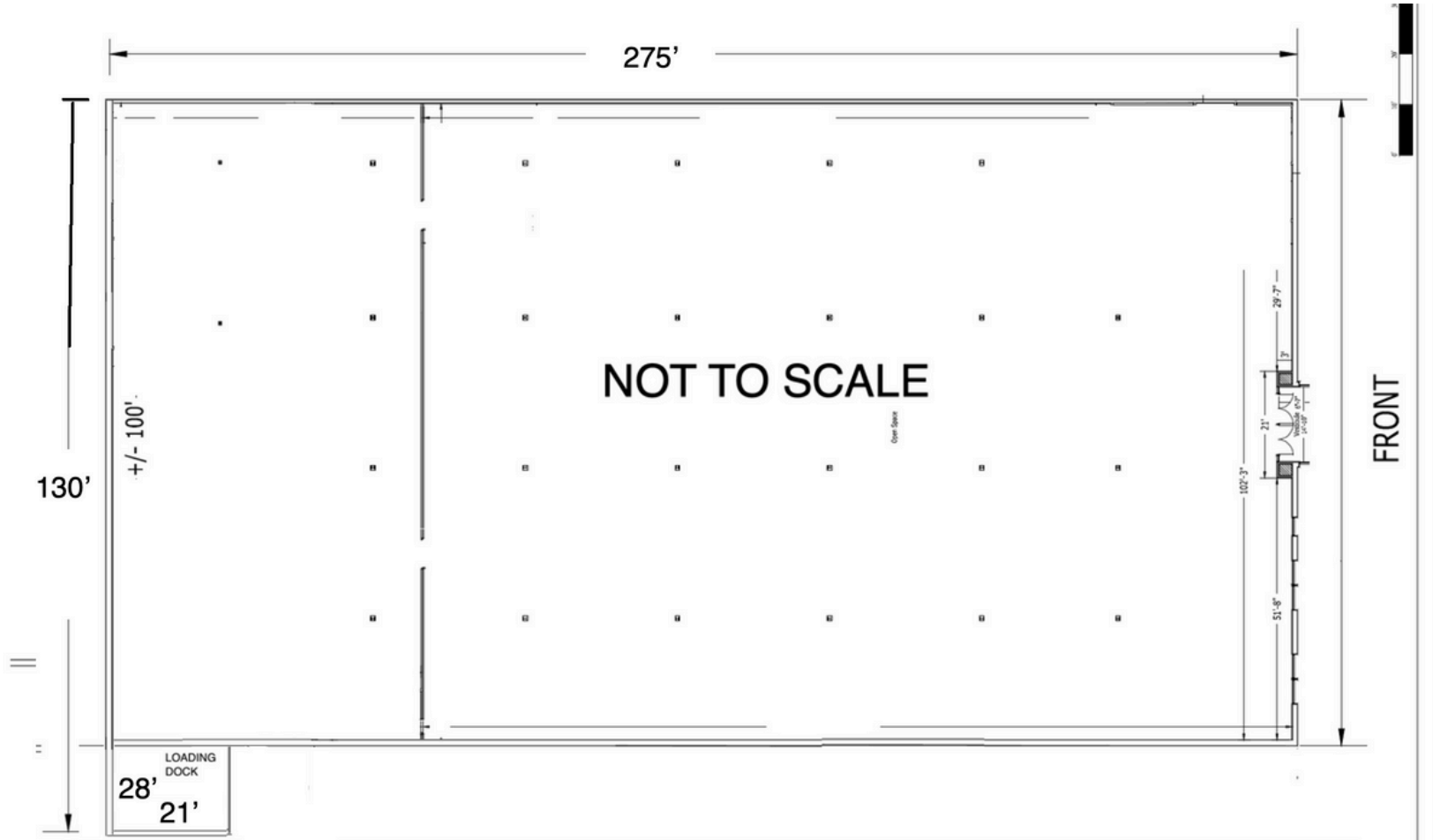

SHAWN ACKERMAN
President
(713) 386-1088 Direct
shawnackerman@henrysmiller.com

HENRY S. MILLER BROKERAGE | HOUSTON
900 Threadneedle St, Suite 120
Houston, Texas 77079
www.henrysmiller.com

SITE PLAN

INGRAM PARK PLAZA
6161 NW LOOP 410
SAN ANTONIO, TX 78238



SHAWN ACKERMAN
President
(713) 386-1088 Direct
shawnackerman@henrysmiller.com

HENRY S. MILLER BROKERAGE | HOUSTON
900 Threadneedle St, Suite 120
Houston, Texas 77079
www.henrysmiller.com





CONTACT US

SHAWN ACKERMAN

President

(713) 386-1088 Direct

shawnackerman@henrysmiller.com

**HENRY S. MILLER, BROKERAGE, LLC
HOUSTON**

900 Threadneedle St, Suite 120

Houston, Texas 77079

www.henrysmiller.com

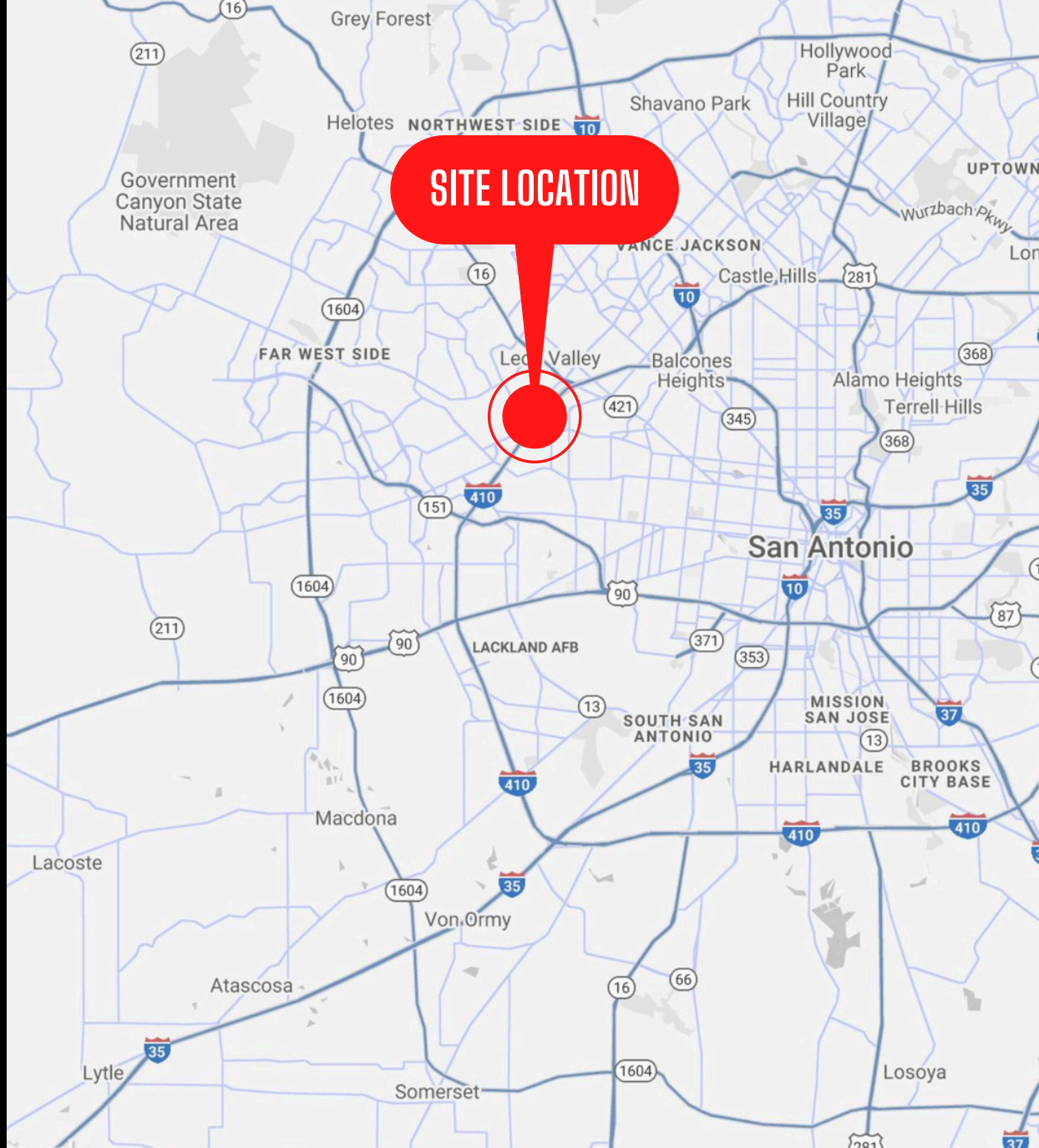

NOTICE & DISCLAIMER: The enclosed information is from sources believed to be reliable, but Henry S. Miller Brokerage, LLC has not verified the accuracy of the information. Henry S. Miller Brokerage, LLC makes no guarantee, warranty or representation as to the information, and assumes no responsibility for any error, omission or inaccuracy. The information is subject to the possibility of errors, omissions, changes of condition, including price or rental, or withdrawal without notice. Any projections, assumptions or estimates are for illustrative purposes only. Recipients should conduct their own investigation.