



MOTE & ASSOCIATES

# Office For Lease

**Cedar Place**  
407 N. Cedar Ridge Road, Duncanville



- 24,000 SF 3-Story Office Building
- Full service gross lease includes utilities and janitorial service
- Approximately 1 mile South of I-20, easy access to I-20 & Hwy 67
- 1 parking space per 224 SF
- Controlled access security system for after-hours entry.
- Elevator in front lobby
- Lobby remodeled in 2019

### Availability:

Suite 235 +/-767 SF \$1,278.33 Mo.

*Waiting room/reception and 2 private offices.*

Suite 237 +/-185 SF \$400.00 Mo.

*One room office.*

Suite 315 +/-775 SF \$1,291.67 Mo.

*Waiting room/reception and 2 private offices.*

Suite 330 +/-1,398 SF \$1,922.25 Mo.

*Waiting room/reception and 3 private offices.*

### Lease Rate:

\$20.00 SF, Full Service Gross

### Zoning:

General Office

### Location:

Mapsco 62-W

Approximately 1 mile South of I-20

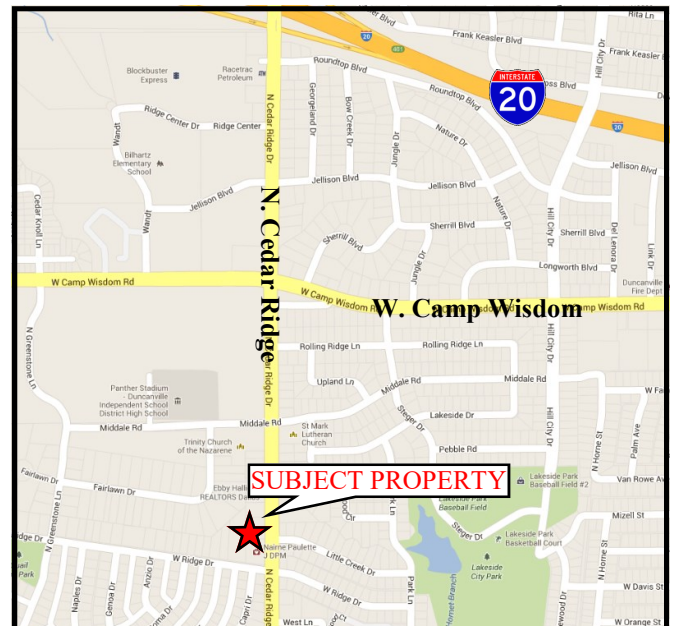

Offered for lease exclusively by:  
**Mote & Associates**  
 Contact: Sarah R. Mitchell  
 O: 972-296-2856  
 M: 469-569-3019  
 SarahM@moteandassociates.com  
 326 Cooper Street, Suite A1  
 Cedar Hill, TX 75104



MOTE & ASSOCIATES

## Suite 235 Floor Plan

Cedar Place  
407 N. Cedar Ridge Road, Duncanville

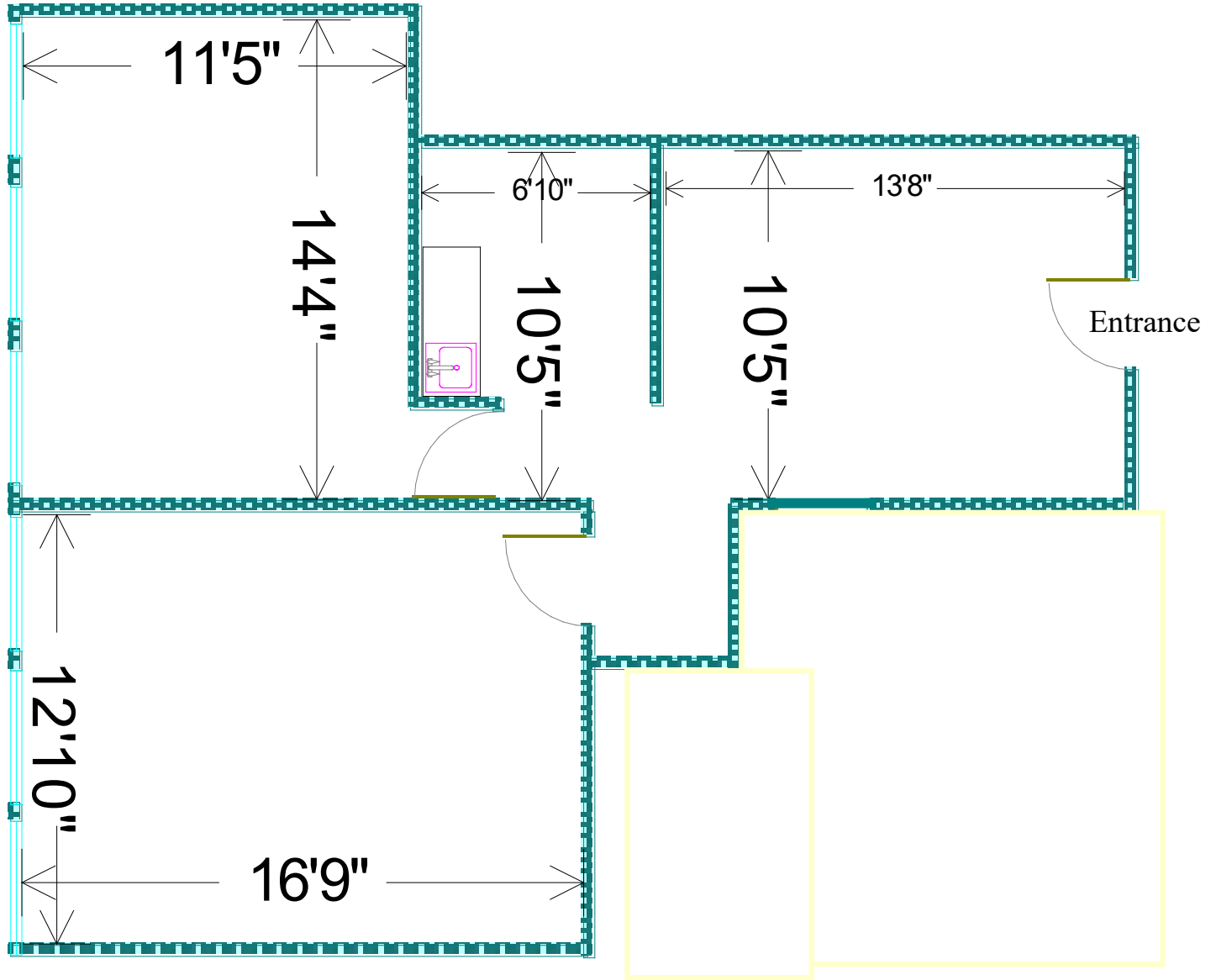

Offered for lease exclusively by:

**Mote & Associates**

Contact: Sarah R. Mitchell

O: 972-296-2856

M: 469-569-3019

SarahM@moteandassociates.com

326 Cooper Street, Suite A1

Cedar Hill, TX 75104



MOTE & ASSOCIATES

## Suite 237 Floor Plan

Cedar Place  
407 N. Cedar Ridge Road, Duncanville

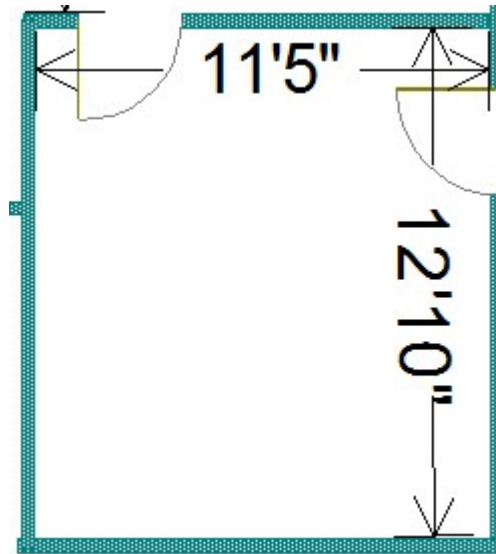

Offered for lease exclusively by:

**Mote & Associates**

Contact: Sarah R. Mitchell

O: 972-296-2856

M: 469-569-3019

SarahM@moteandassociates.com

326 Cooper Street, Suite A1

Cedar Hill, TX 75104



MOTE & ASSOCIATES

## Suite 315 Floor Plan

Cedar Place  
407 N. Cedar Ridge Road, Duncanville

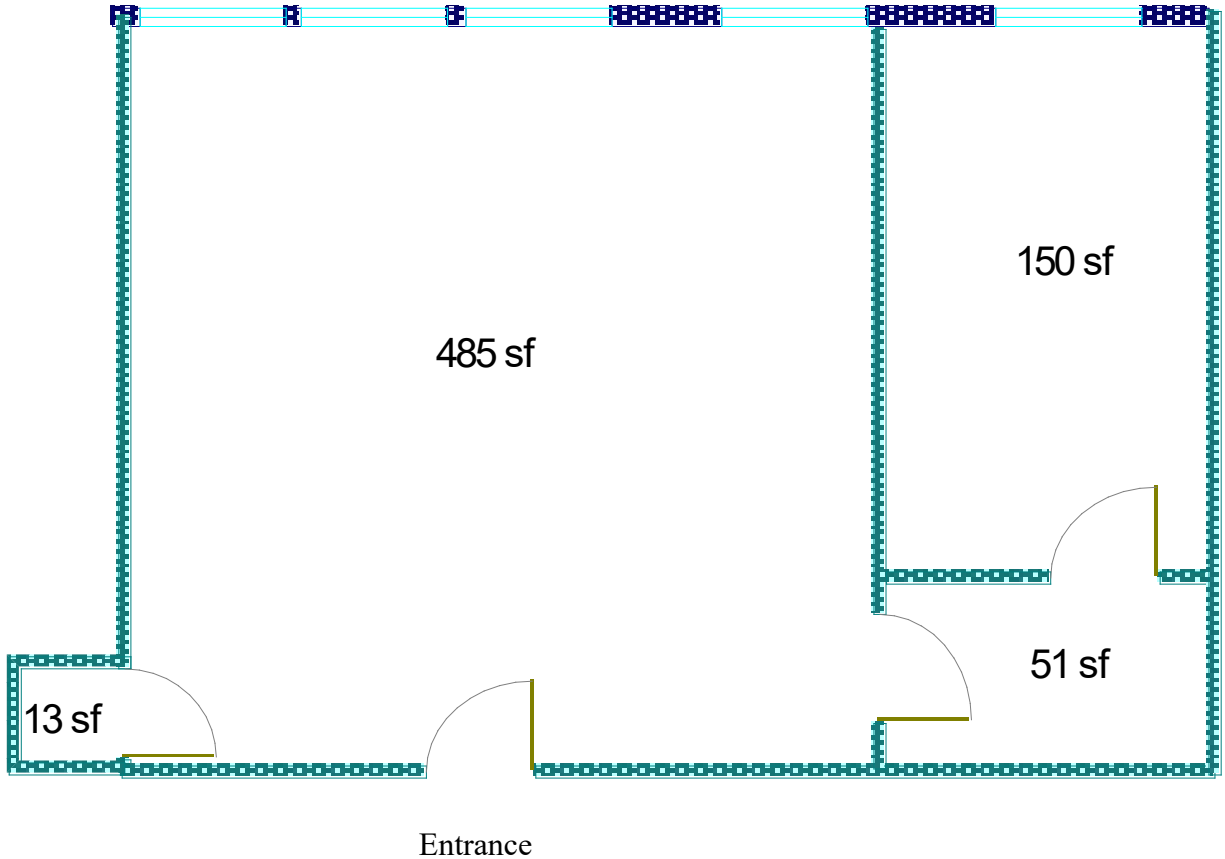

Offered for lease exclusively by:

**Mote & Associates**

Contact: Sarah R. Mitchell

O: 972-296-2856

M: 469-569-3019

SarahM@moteandassociates.com

326 Cooper Street, Suite A1

Cedar Hill, TX 75104



MOTE & ASSOCIATES

## Exterior Photos

Cedar Place  
407 N. Cedar Ridge Road, Duncanville



Offered for lease exclusively by:

**Mote & Associates**

Contact: Sarah R. Mitchell

O: 972-296-2856

M: 469-569-3019

SarahM@moteandassociates.com

326 Cooper Street, Suite A1

Cedar Hill, TX 75104



MOTE & ASSOCIATES

## Lobby Photos

Cedar Place  
407 N. Cedar Ridge Road, Duncanville



Offered for lease exclusively by:

**Mote & Associates**

Contact: Sarah R. Mitchell

O: 972-296-2856

M: 469-569-3019

SarahM@moteandassociates.com

326 Cooper Street, Suite A1

Cedar Hill, TX 75104



MOTE & ASSOCIATES

## Aerial Photo

Cedar Place  
407 N. Cedar Ridge Road, Duncanville



Offered for lease exclusively by:

**Mote & Associates**

Contact: Sarah R. Mitchell

O: 972-296-2856

M: 469-569-3019

SarahM@moteandassociates.com

326 Cooper Street, Suite A1

Cedar Hill, TX 75104

All information has been obtained from a source deemed reliable but is not guaranteed, and broker makes no warranties of any kind with respect to accuracy of such information. Price subject to change without notice.



MOTE & ASSOCIATES

# Business Map

Cedar Place  
407 N. Cedar Ridge Road, Duncanville

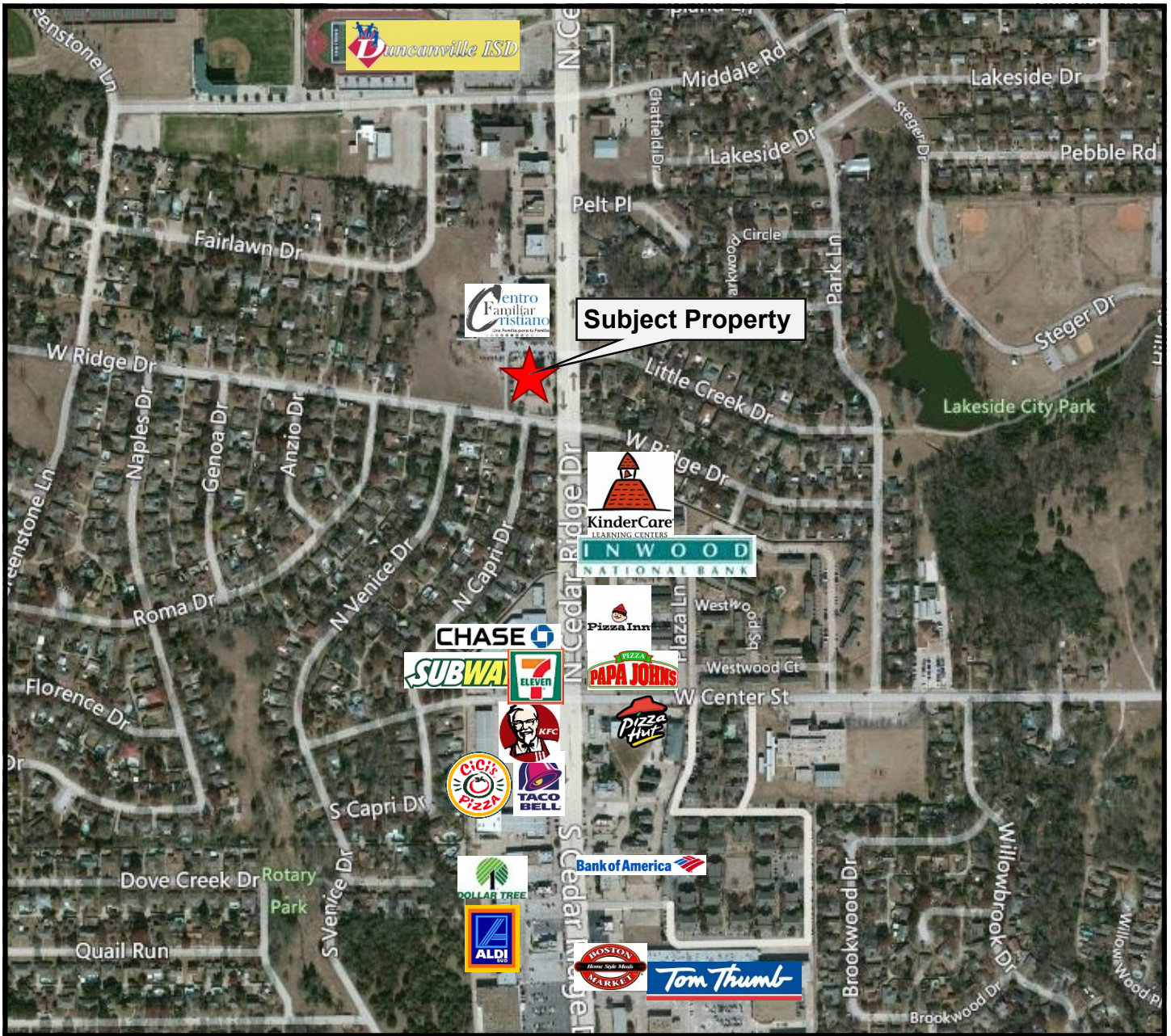

Offered for lease exclusively by:

**Mote & Associates**

Contact: Sarah R. Mitchell

O: 972-296-2856

M: 469-569-3019

SarahM@moteandassociates.com

326 Cooper Street, Suite A1

Cedar Hill, TX 75104





MOTE & ASSOCIATES

## Business Map

**Cedar Place**  
**407 N. Cedar Ridge Road, Duncanville**

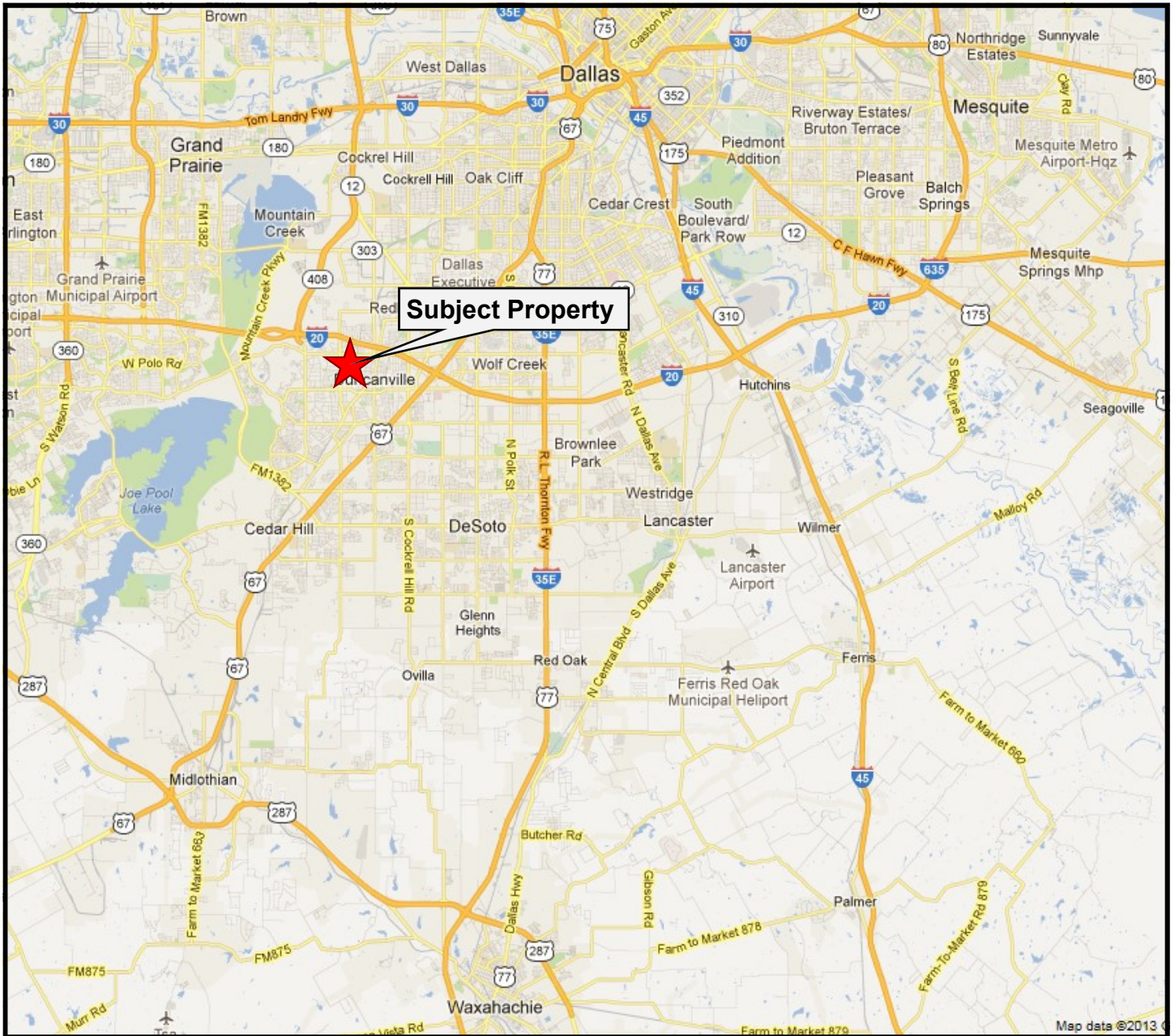

Offered for lease exclusively by:

**Mote & Associates**

Contact: Sarah R. Mitchell

O: 972-296-2856

M: 469-569-3019

[SarahM@moteandassociates.com](mailto:SarahM@moteandassociates.com)

326 Cooper Street, Suite A1

Cedar Hill, TX 75104

All information has been obtained from a source deemed reliable but is not guaranteed, and broker makes no warranties of any kind with respect to accuracy of such information. Price subject to change without notice.

