

## OFFICE SPACE FOR LEASE

# SHADY OAKS PLAZA

6050 Babcock St, Palm Bay, FL 32909



- High Traffic Location
- 3 Entrances for Easy Access
- Ample Parking
- Southwest Corner of Malabar & Babcock
- Near I-95
- 38,500 Daily Traffic Counts
- Competitive Below Market Rates
- Suites 16A, & 19 - 5,082 SF
- Office Area, Large Open Room, Multiple Work Rooms and Offices, Multi Stall Restrooms
- Could be Great for Kids Play Room, Large Tech Office, Banquet Room, and Many Other Uses!
- \$9/SF/YR plus \$4.91/SF/YR NNN

\*Discounted Rate Offered Due to Renovations Needed

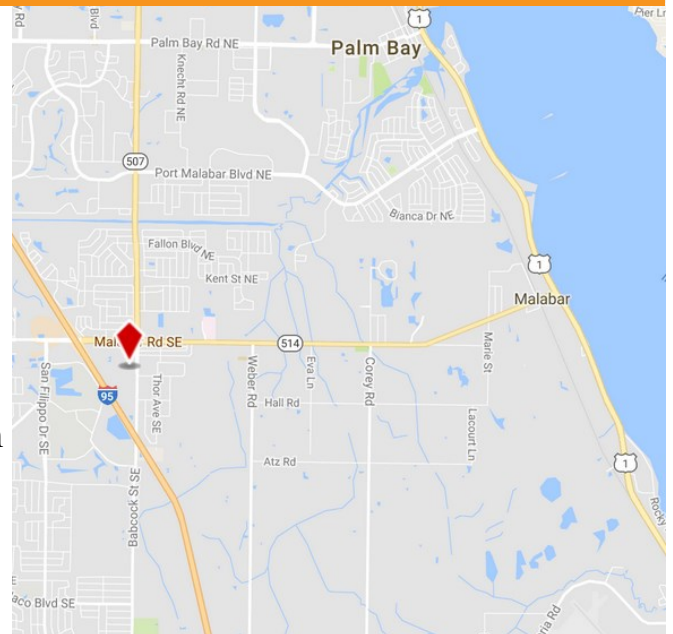

JMREALESTATE.COM



COMMERCIAL  
MANAGEMENT  
LEASING  
SALES

**Courtney Smith**  
JM Real Estate, Inc.  
321.242.2882  
Cell: 321.423.4305  
Courtney@JMRealEstate.com



OFFICE SPACE FOR LEASE

# SHADY OAKS PLAZA

6050 Babcock St, Palm Bay, FL 32909



[JMREALESTATE.COM](http://JMREALESTATE.COM)



COMMERCIAL  
MANAGEMENT  
LEASING  
SALES

**Courtney Smith**

JM Real Estate, Inc.

321.242.2882

Cell: 321.423.4305

[Courtney@JMRealEstate.com](mailto:Courtney@JMRealEstate.com)

Information contained herein has been obtained from others and is considered to be reliable; however, a prospective purchaser, agent, or lessee is expected to verify all information to their satisfaction. We make no guarantee, warranty, or representations herein. Licensed Real Estate Broker.

OFFICE SPACE FOR LEASE

# SHADY OAKS PLAZA

6050 Babcock St, Palm Bay, FL 32909



[JMREALESTATE.COM](http://JMREALESTATE.COM)



COMMERCIAL  
MANAGEMENT  
LEASING  
SALES

**Courtney Smith**  
JM Real Estate, Inc.  
321.242.2882  
Cell: 321.423.4305  
[Courtney@JMRealEstate.com](mailto:Courtney@JMRealEstate.com)

Information contained herein has been obtained from others and is considered to be reliable; however, a prospective purchaser, agent, or lessee is expected to verify all information to their satisfaction. We make no guarantee, warranty, or representations herein. Licensed Real Estate Broker.



OFFICE SPACE FOR LEASE

# SHADY OAKS PLAZA

6050 Babcock St, Palm Bay, FL 32909

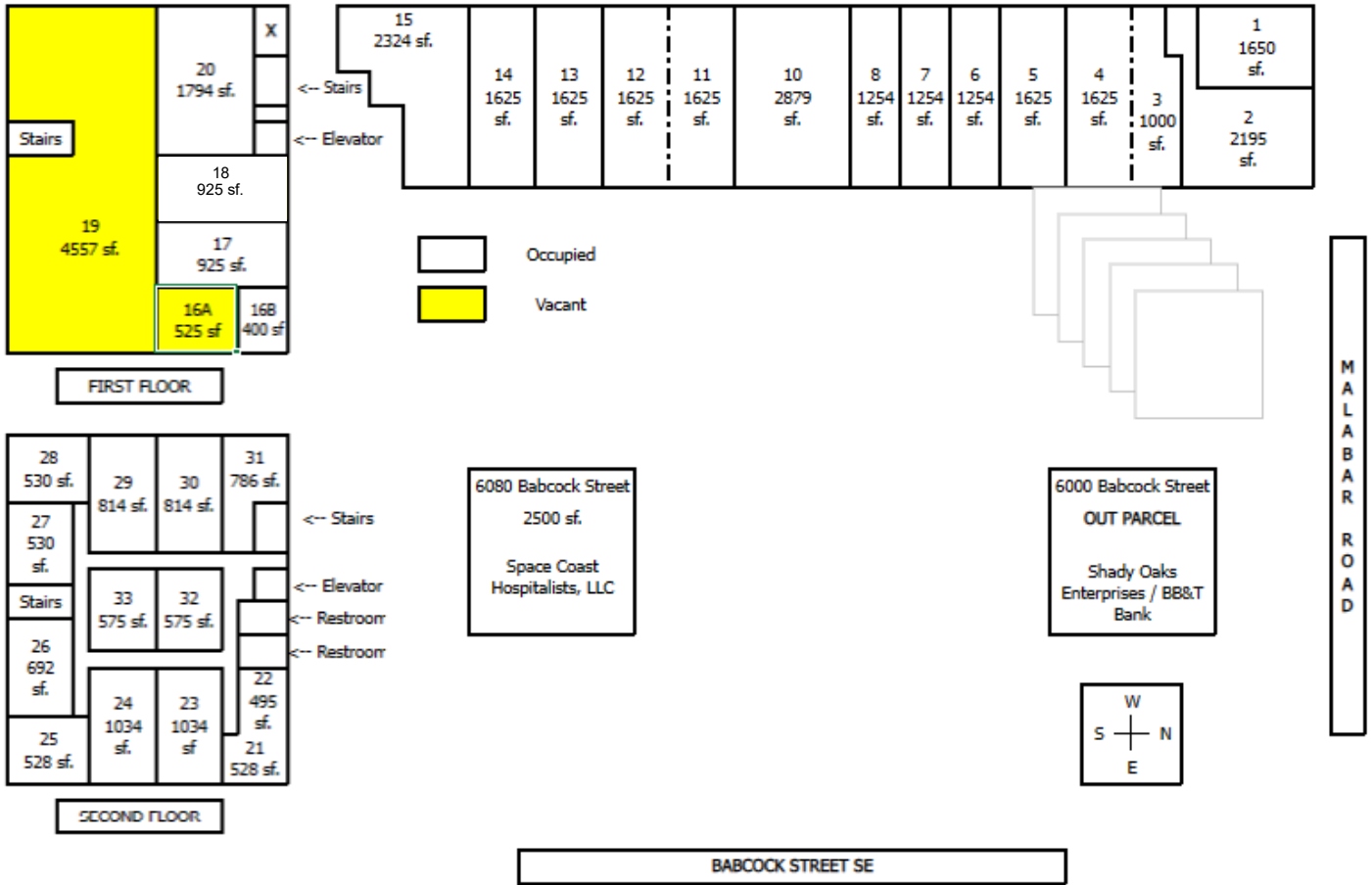

JMREALESTATE.COM



COMMERCIAL  
MANAGEMENT  
LEASING  
SALES

**Courtney Smith**  
 JM Real Estate, Inc.  
 321.242.2882  
 Cell: 321.423.4305  
 Courtney@JMRealEstate.com

Information contained herein has been obtained from others and is considered to be reliable; however, a prospective purchaser, agent, or lessee is expected to verify all information to their satisfaction. We make no guarantee, warranty, or representations herein. Licensed Real Estate Broker.