



# FULLY EQUIPPED RESTAURANT

2330 MCMENAMIN STREET | HAMPTON, VA 23666

## FEATURES

- **5,803 SF 2nd generation restaurant available now**
- Full bar and kitchen, tables and seating for 250+ people
- Patio with seating for 50+ people
- NNN \$8.25, call agent for pricing
- Located in *Peninsula Town Center*, a heavily trafficked destination shopping center in Hampton Roads
- Over 340 existing residential units
- Over 15,000 students between Hampton University and Christopher Newport University

|                           |   |               |               |
|---------------------------|---|---------------|---------------|
| <b>SPACE TYPE</b>         | Restaurant for Lease  |               |               |
| <b>AVAILABLE SPACE</b>    | 5,803 SF  |               |               |
| <b>LEASE RATE</b>         | Ask Agent   |               |               |
| <b>DEMOGRAPHICS</b>       | <b>1 Mile</b>   | <b>3 Mile</b> | <b>5 Mile</b> |
| <b>2025 Population</b>    | 13,079  | 82,772        | 202,980       |
| <b>Avg HH Income</b>      | \$67,946  | \$73,780      | \$76,647      |
| <b>Daytime Employment</b> | 15,067  | 43,034        | 112,690       |
| <b>Traffic Count</b>      | 61,000 VPD on W. Mercury Blvd<br>23,500 VPD on Coliseum Drive |               |               |



**Tyler Schleinkofer:** 804.864.9788 ext. 108 (o)  
 804.904.7010 (m)  
 tylerschleinkofer@taylorlongproperties.com

**Robert Marshall:** 804.864.9788 ext. 102 (o)  
 804.437.4323 (m)  
 robertmarshall@taylorlongproperties.com

CoStar  
**POWER BROKER**  
 Top Broker Award

**RETAIL BROKERS**  
 NETWORK

**Taylor Long**  
**PROPERTIES**  
 Commercial Real Estate



# SITE PLAN

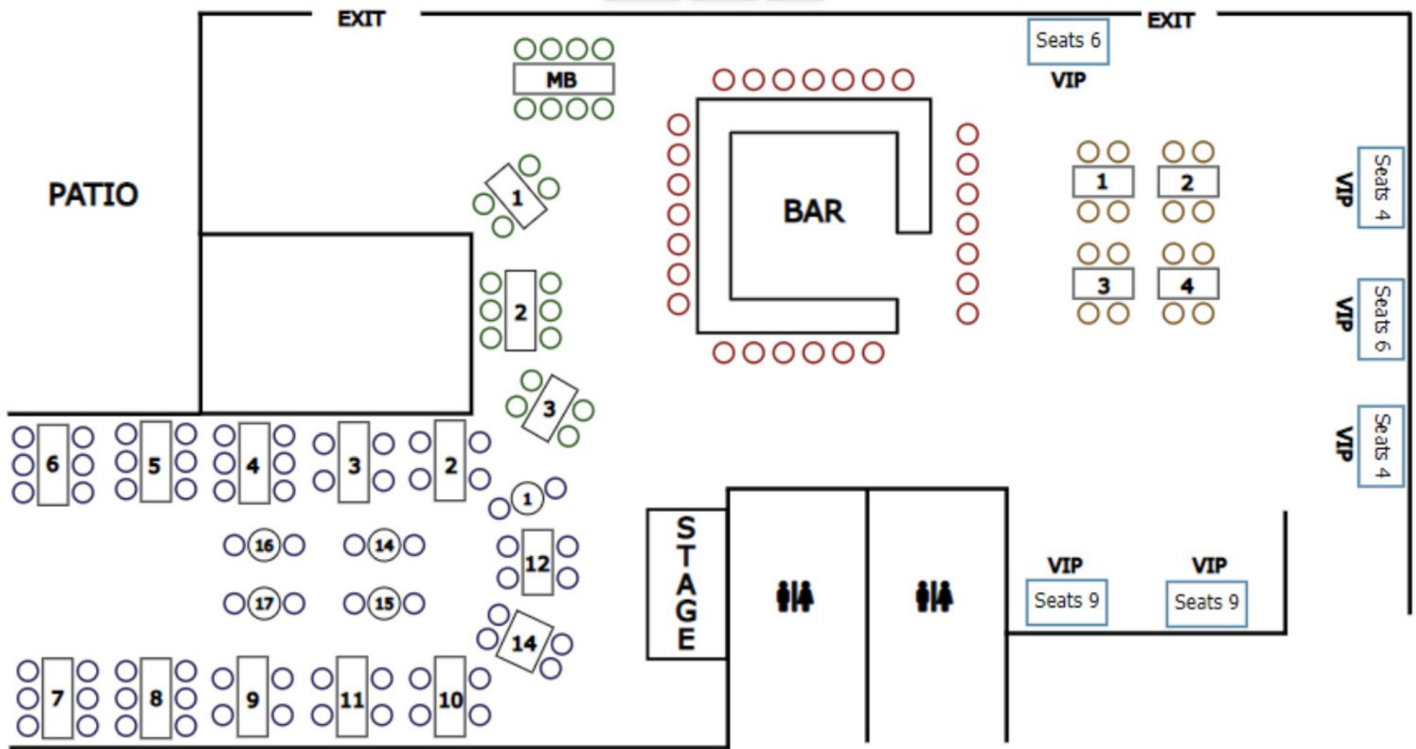



# AERIAL





## AERIAL





# PHOTOS





# PHOTOS

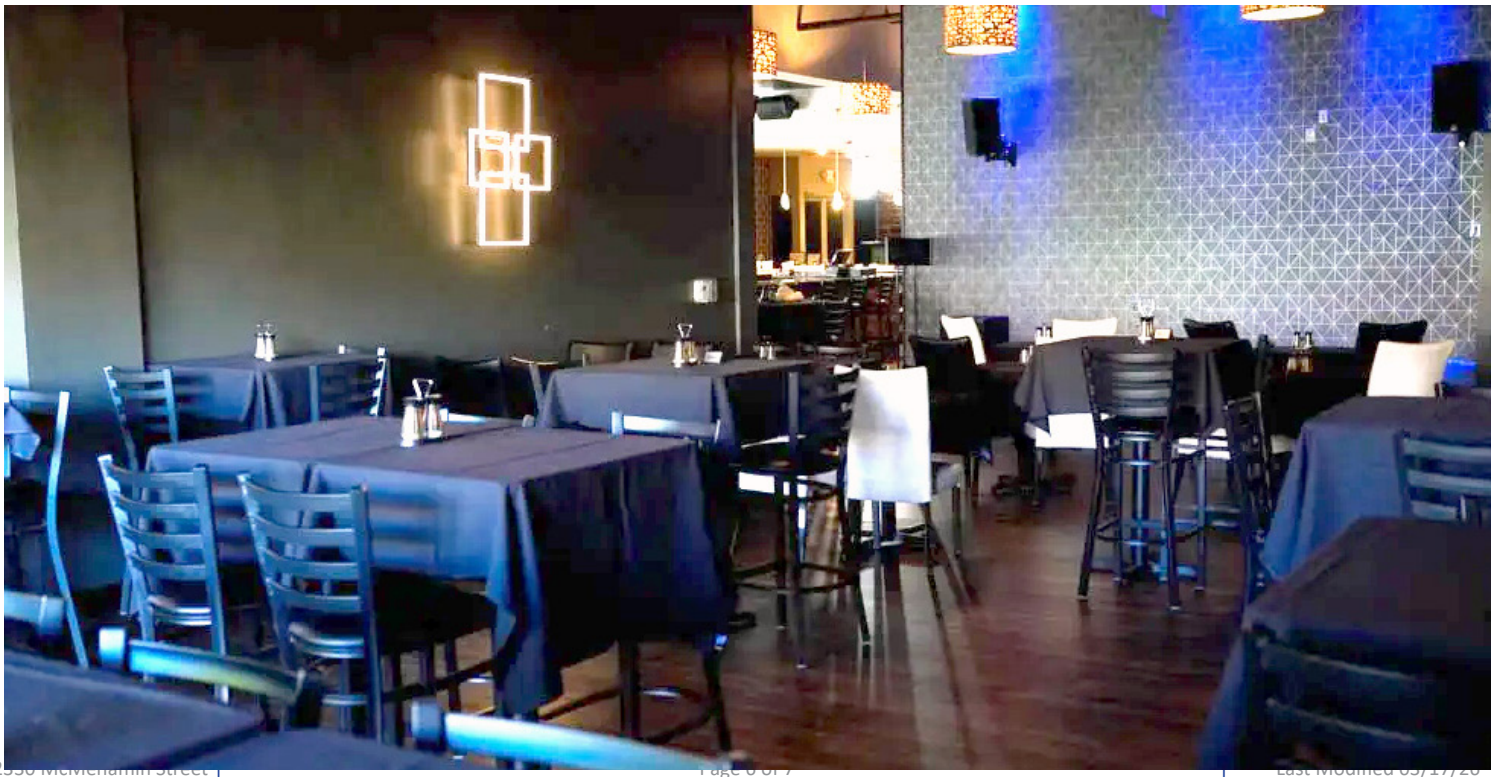
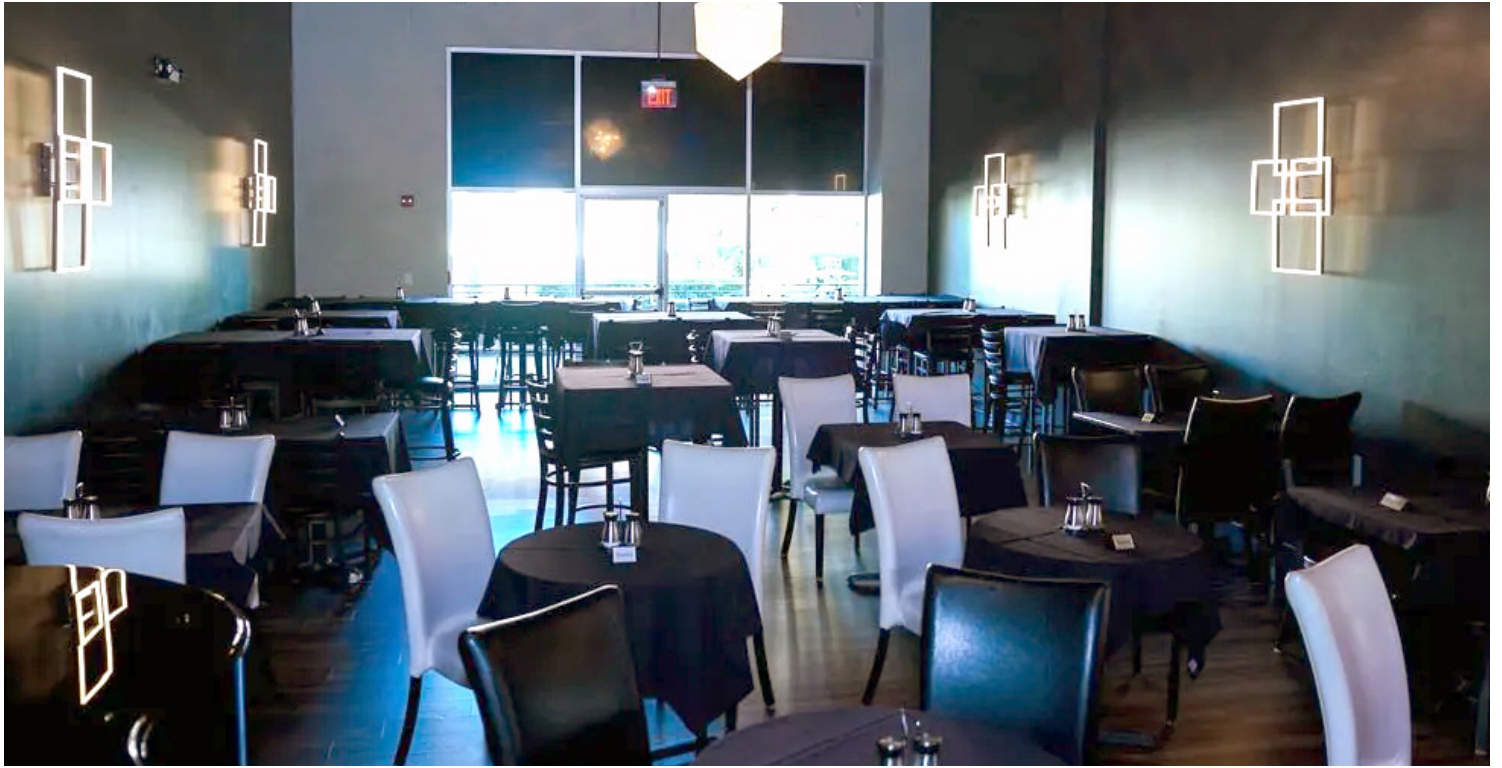

2550 Westchase Drive

Page 6 of 7

Last Modified 05/29/20



PHOTOS

