

FOR LEASE



STEFON PLAZA

200 ARMY POST RD

Des Moines, Iowa 50315

Retail Space For Lease
from 1,400 - 4,200 RSF ±

ANGIE TESSAU, CCIM, SIOR
515.707.6889
AngieT@KnappLC.com
Licensed in IA

KOREY BIRKENHOLTZ
515.480.6596
Korey@KnappLC.com
Licensed in IA

200 ARMY POST RD FOR LEASE



BUILDING HIGHLIGHTS

- Ample parking
- Local ownership
- Responsive property management
- High traffic count
- Great visibility

Stefon Plaza is conveniently located between Southridge Mall and Des Moines International Airport with easy access to Highway 5.

RETAIL SPACE

SUITE #20 - 1,560 RSF *Available: 4/1/2026*

SUITE #54 - 1,400 RSF *Available: immediately*

SUITE #56 - 2,800 RSF *Available: 11/1/2026*

Suite 54 & 56 Total Contiguous: 4,200 RSF

LEASE RATE: \$9.75 PSF NNN

ANGIETESSAU, CCIM, SIOR
angiet@knappc.com
515.707.6889
Licensed in IA

KOREY BIRKENHOLTZ
korey@knappc.com
515.480.6596
Licensed in IA



RETAIL SPACE



RESTAURANT SPACE



MANAGED BY KNAPP PROPERTIES



PARKING LOT



EXCELLENT LOCATION



AIRPORT NEARBY



GROCERY STORE NEARBY



GOLF COURSE NEARBY



HOTEL NEARBY

200 ARMY POST ROAD AVAILABILITY

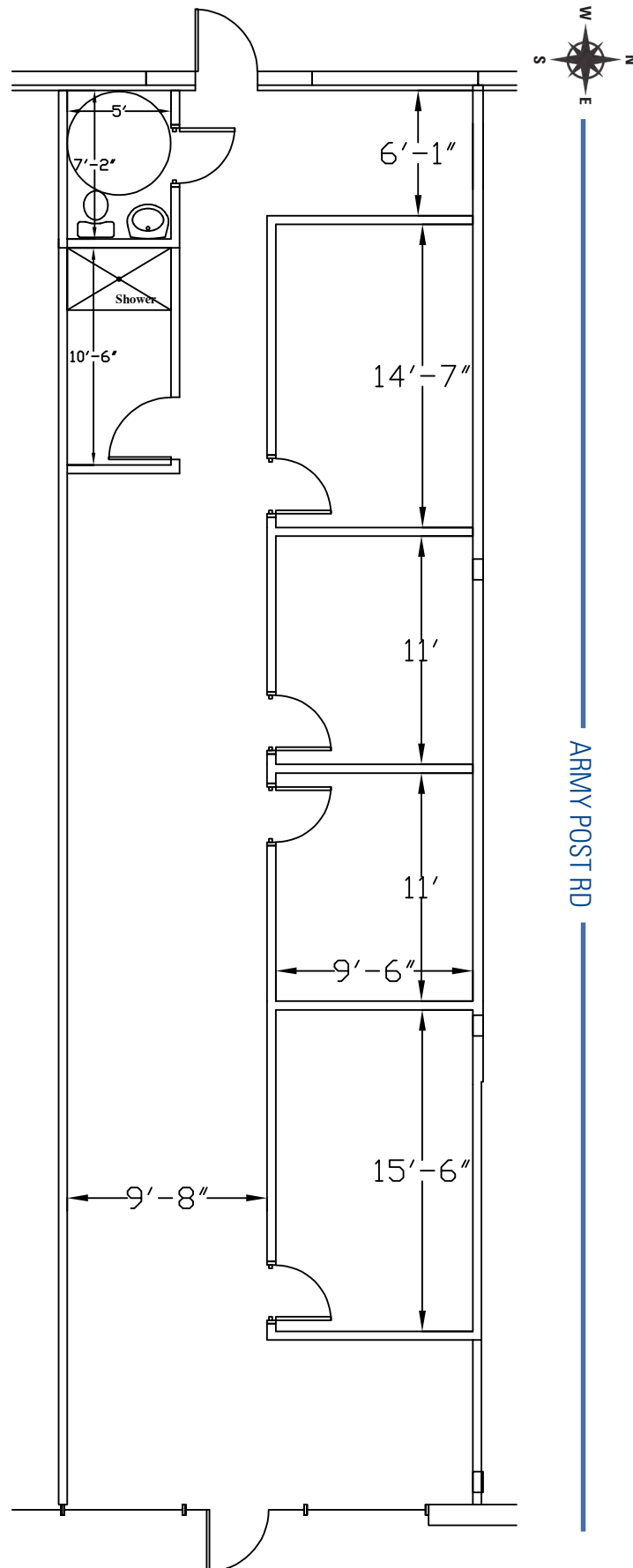

SUITE 54

1,400 RSF ±

Available:
immediately

Lease Rate:
\$9.75 PSF NNN

Total Contiguous:
4,200 RSF

200 ARMY POST ROAD AVAILABILITY

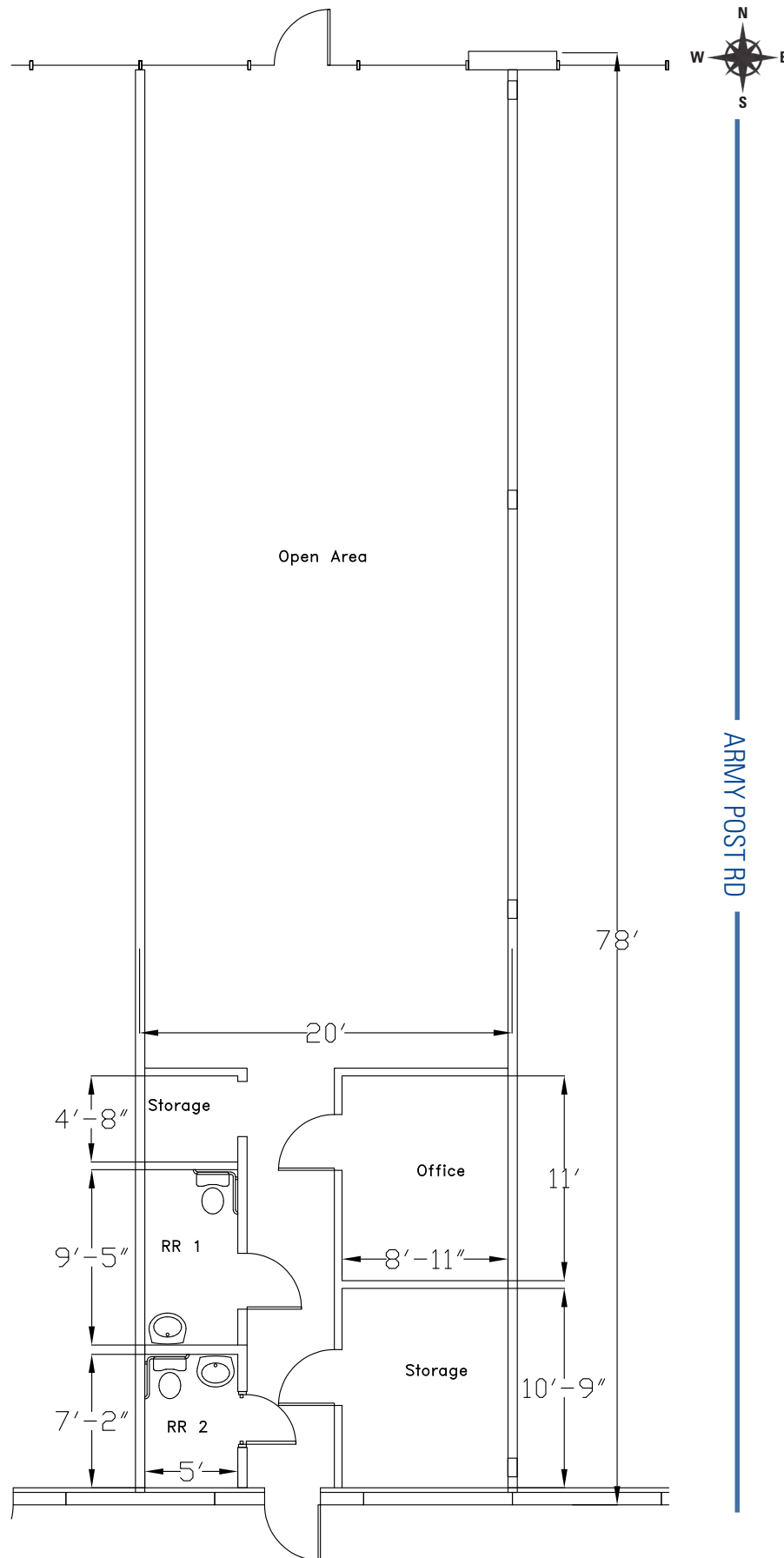

SUITE 20
1,560 RSF ±

Available:
4/1/2026

Lease Rate:
\$9.75 PSF NNN

DEMOGRAPHICS

200 ARMY POST ROAD

5 mile radius

INCOME



\$57,163

Median Household Income



\$78,535

Median Net Worth



\$189,171

Median Home Value



\$47,652

Median Disposable Income

EDUCATION



32%

Bachelor's/Grad/Prof Degree

BUSINESS



4,703

Total Businesses



112,891

Total Employees

KEY FACTS



1,341.0

Population



154,254

Total Daytime Population



35.9

Median Age



45,229

Households

TRAFFIC



19,400

Army Post Road

EMPLOYMENT



3.7%

Unemployment Rate

nearby ATTRACTIONS

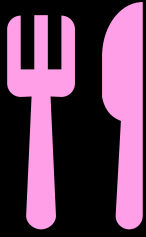

268

Restaurants



30

Bars and
Pubs



19

Coffee
Shops



25

Grocers



40

C-Stores



56

Retail
Shopping



35

Hotels



60

Attractions/
Entertainment

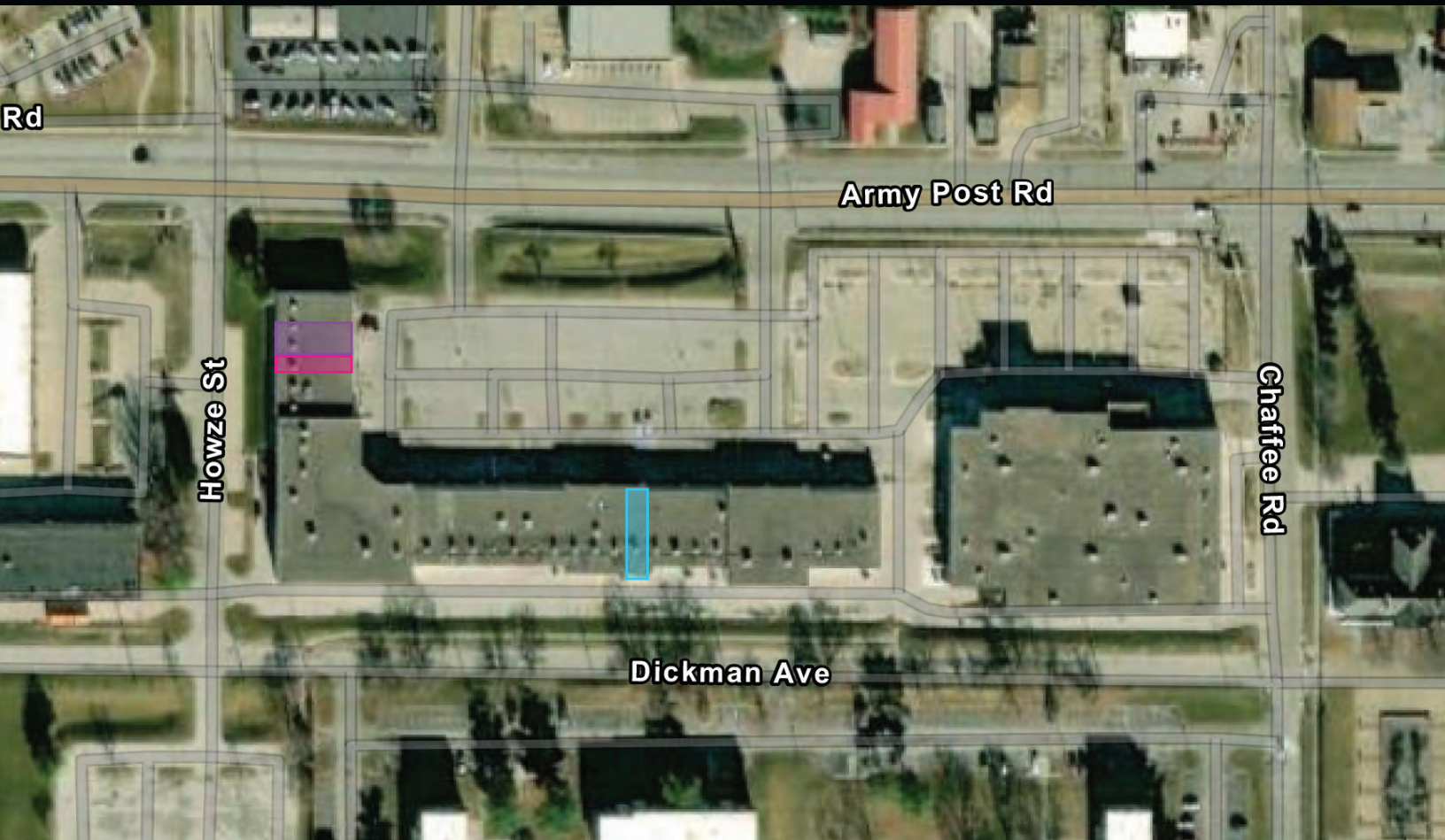

FOR LEASE 200 ARMY POST ROAD

Des Moines, Iowa 50315



KNAPP
PROPERTIES



ANGIE TESSAU, CCIM, SIOR

515.707.6889

AngieT@KnappLC.com



KOREY BIRKENHOLTZ

515.480.6596

Korey@KnappLC.com

All interested parties acknowledge that neither Seller nor any of Seller's officers or directors, nor Seller's employees, agents, representatives, or any other person or entity acting on behalf of Seller (hereafter, such persons and entities are individually and collectively referred to as the "Seller"), have made any representations, warranties or agreements (express or implied) by or on behalf of Seller as to any matters concerning the Property, the economic results to be obtained or predicted, or the present use thereof or the suitability for the possible intended use of the Property. Any documents furnished by Seller relating to the Property shall be deemed furnished as a courtesy to any interested party but without warranty or representation from Seller. All work done in connection with preparing the Property for the uses intended by any interested party shall be obtained and paid for by, and shall be the sole responsibility of the interested party. All investigations of proposed governmental laws and regulations, including land use laws and regulations to which the Property may be subject, shall be based on the review and determination of the applicability and effect of such laws and regulations by the interested party. Seller makes no representations concerning such laws and regulations.