

HERSON WAREHOUSE CONSTRUCTION PLAN

CIVIL CONSTRUCTION PLANS & SPECIFICATIONS
SECTION XX, TOWNSHIP XX S, RANGE XX E
FORT PIERCE, FLORIDA

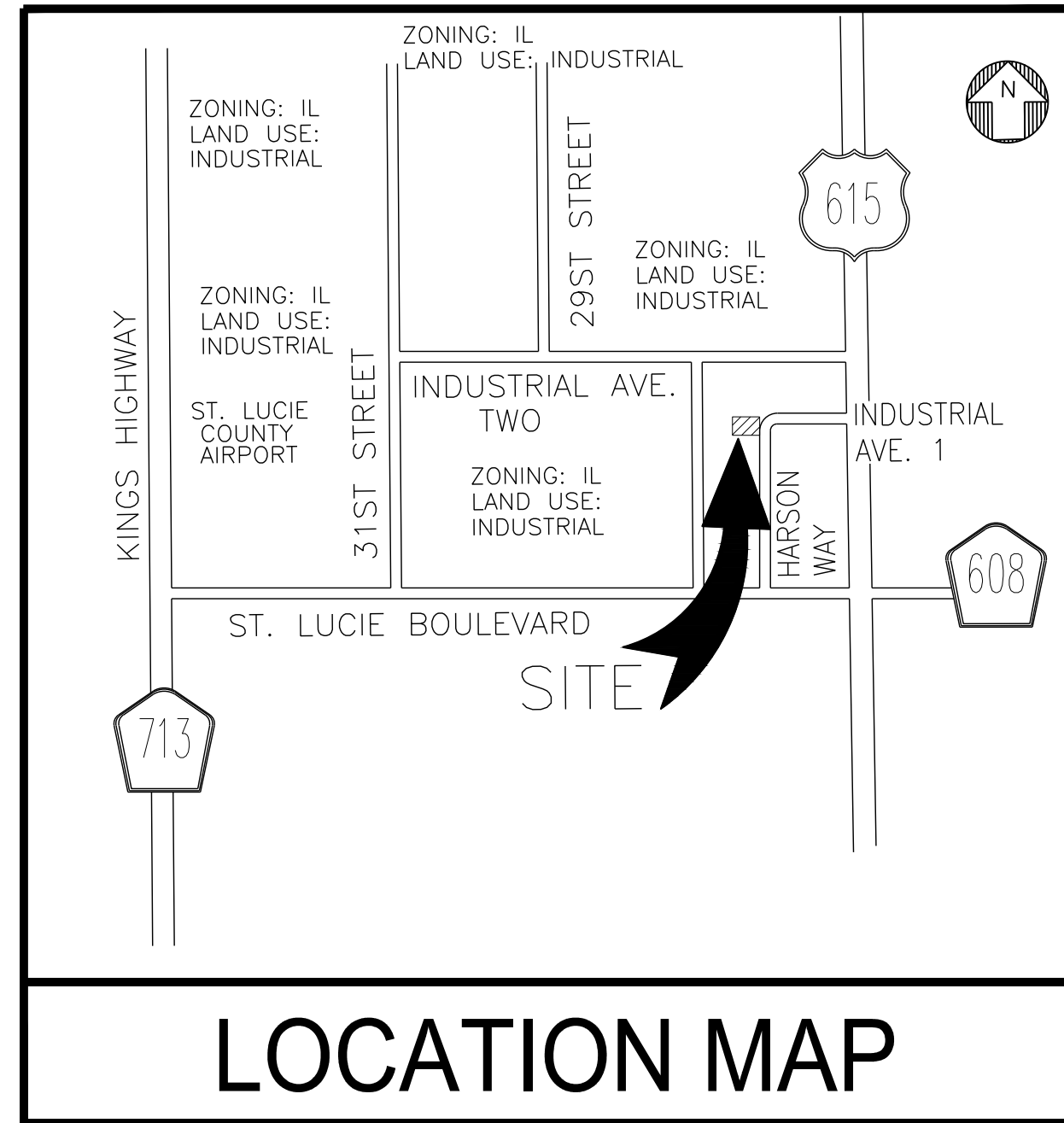

LOCATION MAP

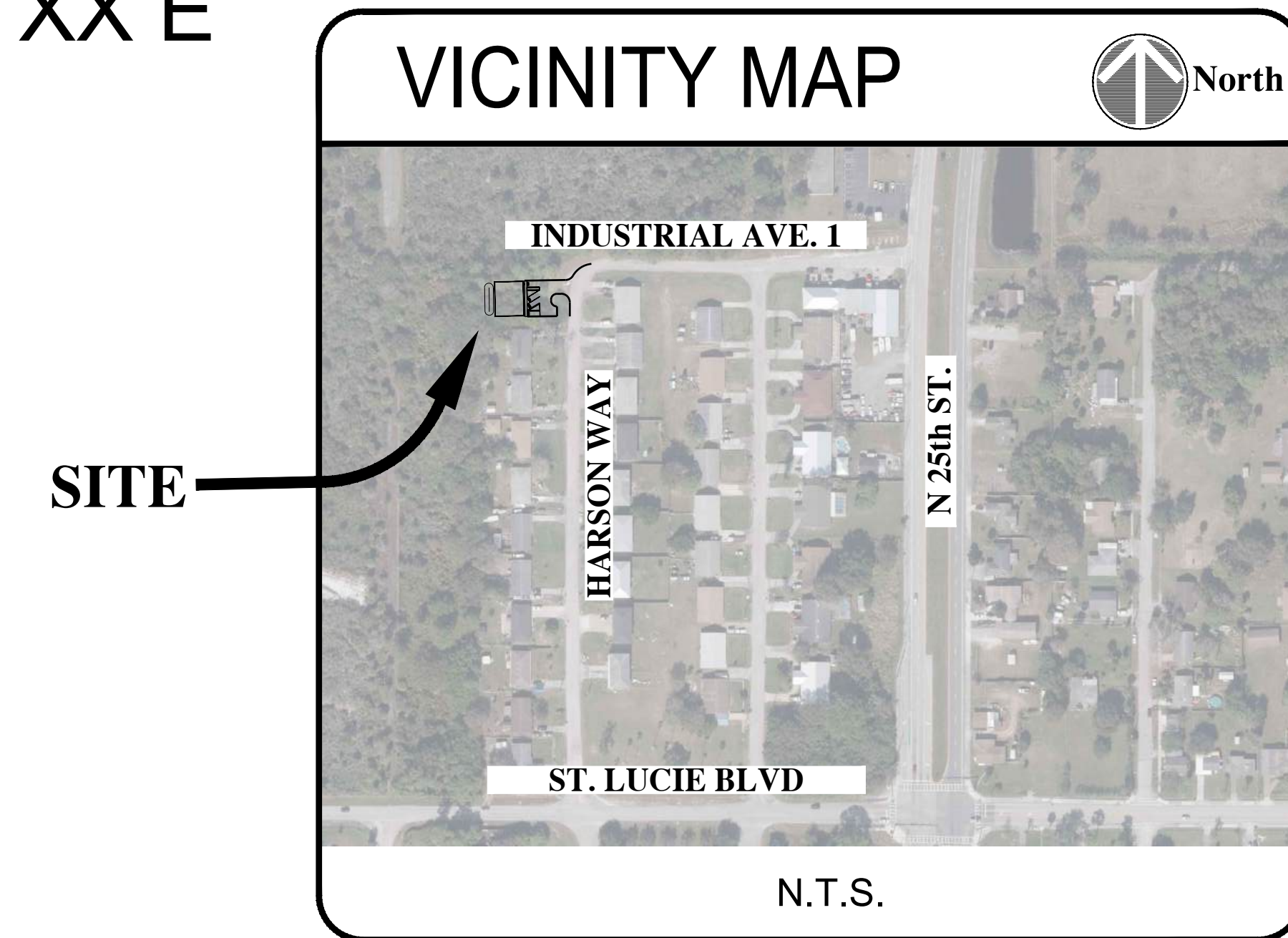

SHEET INDEX	
Sheet Number	Sheet Title
C-01	Cover
C-02	NOTES
C-03	SITEPLAN
C-04	PGD
C-05	DETAILS
C-06	UTILITIES
C-07	FPUA DETAILS-01
C-08	FPUA DETAILS-02

PROJECT INFORMATION

PROJECT NAME: HERSON WAREHOUSE
 PROJECT ADDRESS: 2933 HARSON WAY
 FORT PIERCE, FL 34946
 ENGINEER: KMA ENGINEERING & SURVEYING, LLC
 3001 INDUSTRIAL AVENUE 2
 FT. PIERCE, FL 34946
 (772) 569-5505
 blaine@kmafl.com
 SURVEYOR: XXXXXXXX
 XXXXXXXX
 XXXXXXXX
 XXXXXXXX
 PROJECT DESCRIPTION: SAN LUCIE PLAZA S/D-UNIT ONE-BLK 60N 30FT. OF
 LOT 17 AND ALL LOT 18 (MAP 14/29S)
 SEC-TOWNSHIP-RANGE: SECTION 29 TOWNSHIP 34S RANGE 40E

REQUIRED PERMITS

ST. LUCIE COUNTY RW
 FPUA
 FDEP SEWER EXTENSION
 NDPS SWWP

NOTE:
 FT. PIERCE UTILITY AUTHORITY
 STANDARDS AND DETAILS EFFECTIVE 2009

ENGINEER & SURVEYOR

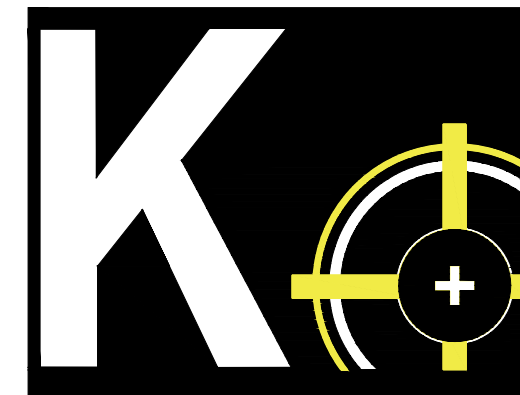

KMA
 ENGINEERING & SURVEYING, LLC.

3001 INDUSTRIAL 2 AVENUE
 FT. PIERCE, FL 34946
 PHONE: (772) 569-5505
 FBPE C.O.A. # 33705

ENGINEER'S PROJECT NO. 24-1004

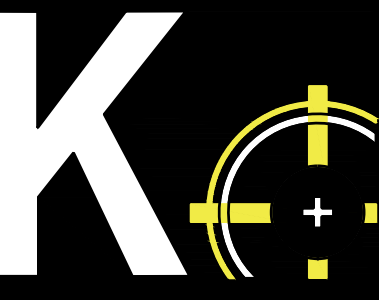

KMA
 ENGINEERING & SURVEYING, LLC
 2945 14TH AVE. SUITE #3
 VERO BEACH, FL 32960
 PHONE: (772) 569-5505
 FBPE C.O.A. # 33705

REVISIONS:	BY:	DATE:	COMMENT:

NOT FOR
 CONSTRUCTION

PROJECT:
**HARSON WAREHOUSE
 CONSTRUCTION PLAN**
 FORT PIERCE, FLORIDA

CLIENT:
**EAST COAST
 CONSULTANT GROUP
 LLC**
 707 WEST BOULEVARD CHATELAIN
 DELRAY BEACH, FL 33445

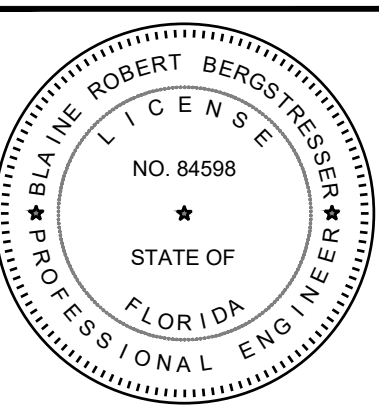

BLAINE BERGSTRESSER, P.E.
 FLORIDA LICENSE No. 84598
 8/12/2024



PROJECT No.: 24-1004
 DRAWN BY: SCB
 CHECKED BY: BRB
 DATE: 08/07/2024

SHEET TITLE:
COVER SHEET

SHEET NUMBER:
C-01

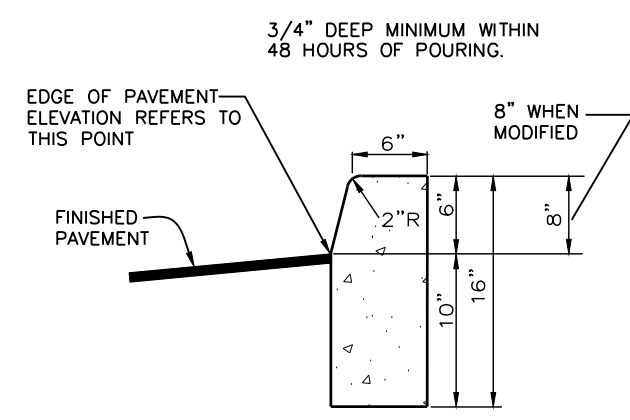

TYPE 'D' CURB

N.T.S.

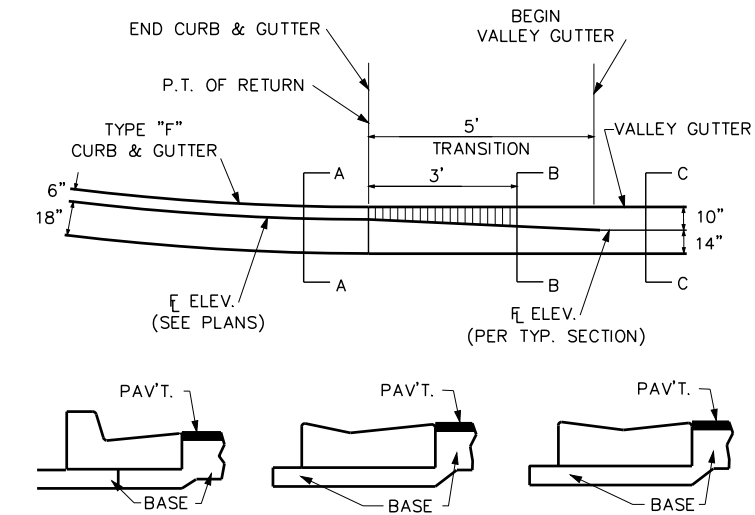

TRANSITION FROM CURB & GUTTER TO MODIFIED VALLEY GUTTER

N.T.S.

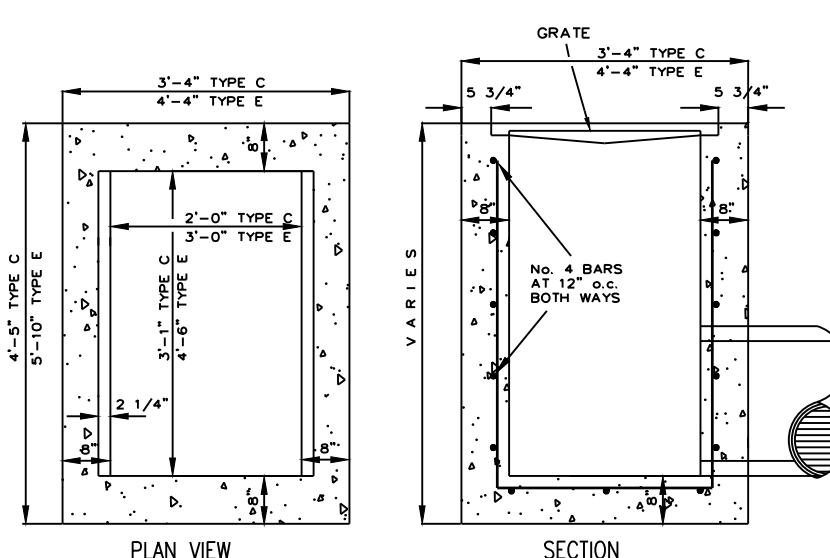

TYPE "C" & "E" INLETS

N.T.S.

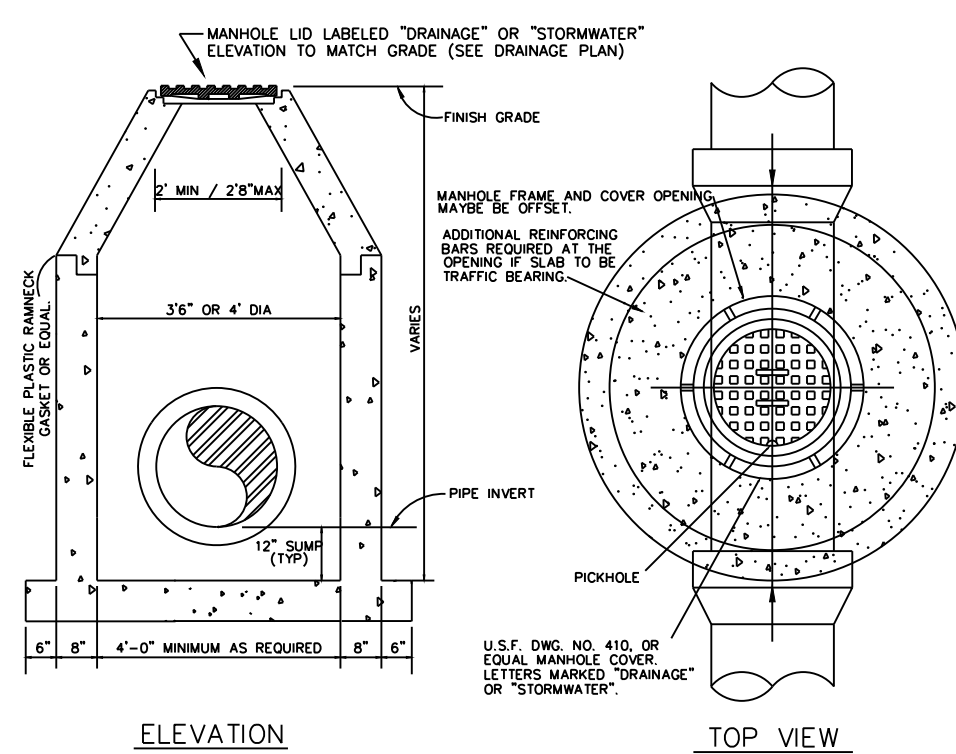

TYPICAL DRAINAGE JUNCTION BOX

N.T.S.

- NOTE:
- 3/4" CRUSHED STONE FOUNDATION FOR A MINIMUM DEPTH OF 12" SHALL BE PROVIDED.
 - ALL DRAINAGE MANHOLES TO BE CONSTRUCTED IN ACCORDANCE WITH STRUCTURAL BOTTOMS, TYPE P AND J, F.D.O.T. STANDARD INDEX NO. 200. WITH PRE-CAST MANHOLE TOP TYPE 7 OR 8, F.D.O.T. STANDARD INDEX NO. 201. FOR USE IN TRAFFIC BEARING APPLICATIONS.

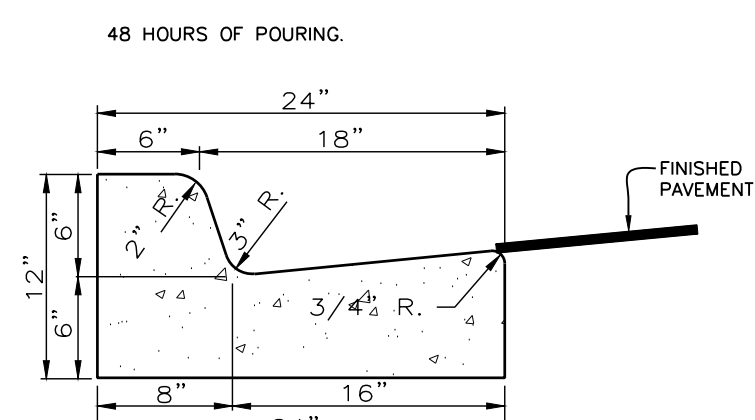

TYPE 'F' CURB

N.T.S.

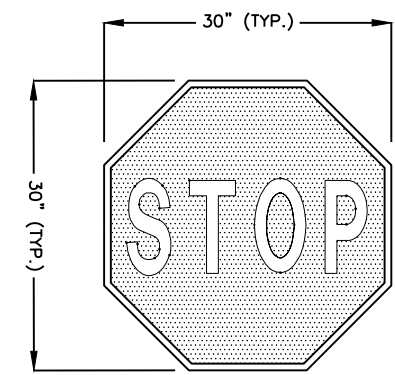

R1-1

N.T.S.



W11A-2

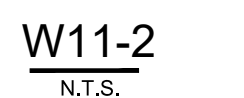

W11-2

N.T.S.

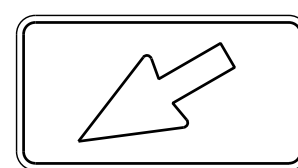

W16-7PL

N.T.S.

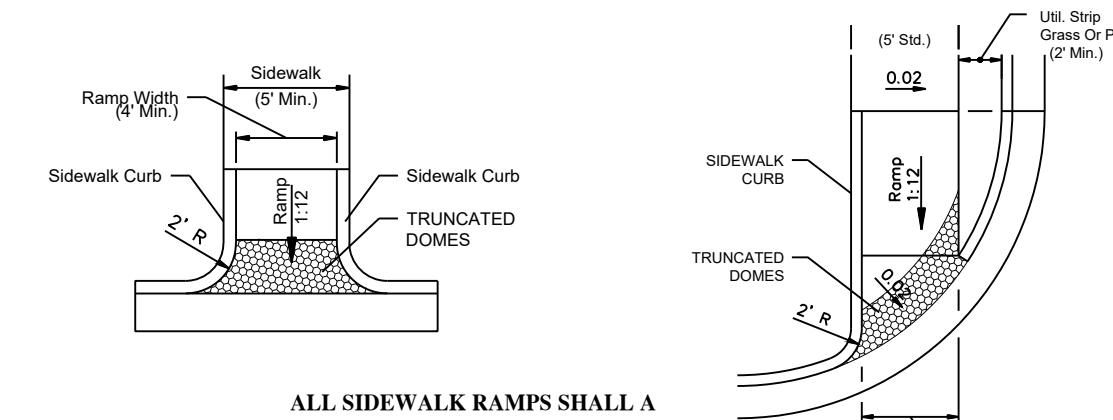

ALL SIDEWALK RAMP SHALL A MINIMUM 2" TACTILE SURFACE (TRUNCATED DOMES) AS INDICATED IN THE DETAILS BELOW.

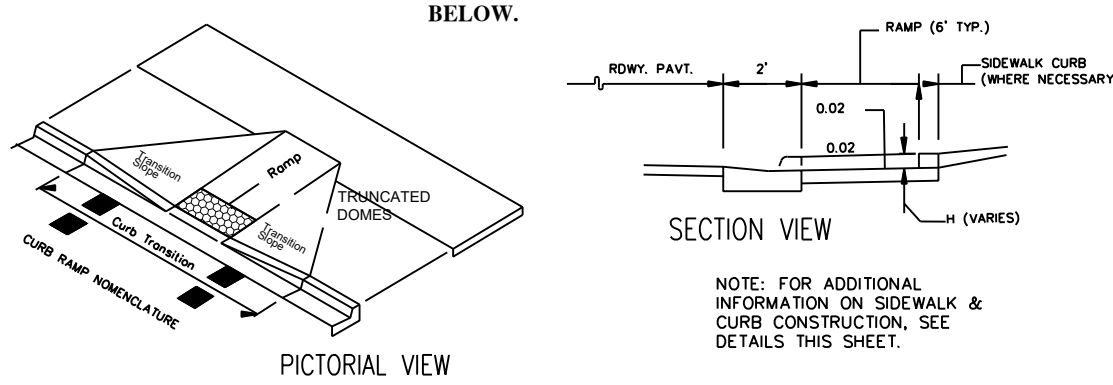

SIDEWALK CURB RAMP DETAIL FDOT CR-E

N.T.S.

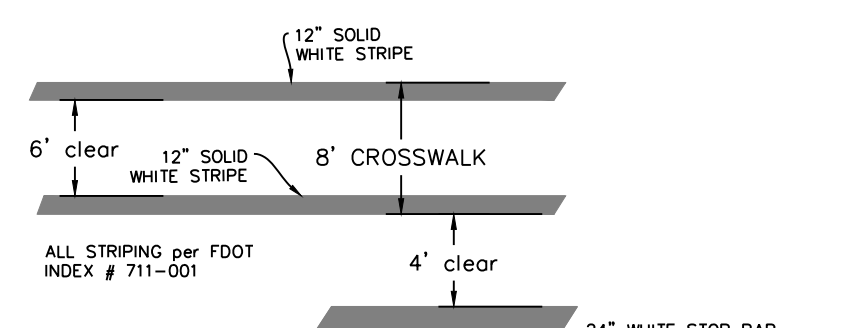

TYPICAL PEDESTRIAN CROSSWALK STRIPING

N.T.S.

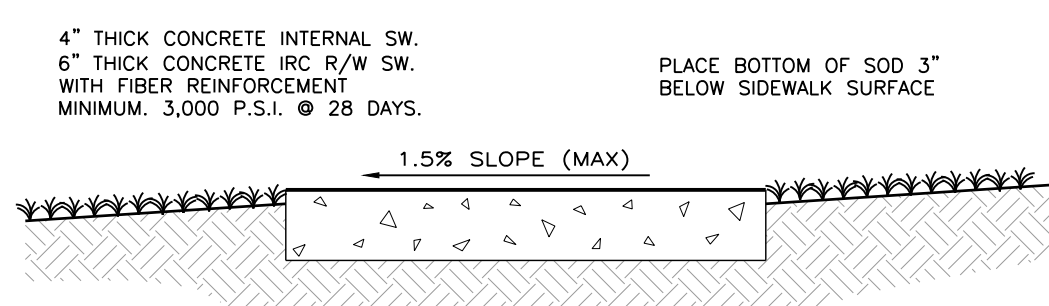

SIDEWALK DETAIL

N.T.S.

SIDEWALK NOTES:

- ALL MATERIALS AND CONSTRUCTION PROCEDURES SHALL BE IN ACCORDANCE WITH THE "SUGGESTED SPECIFICATIONS FOR CONCRETE AREAS" PREPARED BY THE PORTLAND CEMENT ASSOCIATION.
- CONTROL JOINTS SHALL BE CONSTRUCTED AT A MAXIMUM OF 8'-FEET.
- AT LEAST THREE (3) COMPRESSIVE STRENGTH CYLINDER SAMPLES SHALL BE TAKEN FOR EACH 10,000 SQUARE FEET OF PAVEMENT OR FIVE (5) PER JOB, WHICHEVER IS GREATER. SLUMP SHALL BE 2 TO 4 INCHES (ASHTO T-119). COMPRESSIVE STRENGTH SHALL BE REPORTED AT 7, 14, AND 28 DAYS.
- CONSTRUCT LIP ON FIRM, STABILIZED GROUND, COMPACTED TO 95% MAXIMUM DRY DENSITY.
- SURFACE WITH BROOM FINISH.
- SIDEWALK LOCATION AND DETAILS PER FDOT INDEX #310, LATEST EDITION.

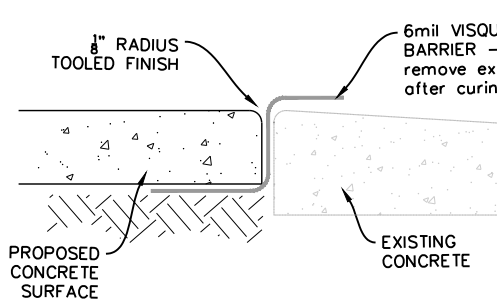

CONCRETE BUTT JOINT DETAILS

N.T.S.

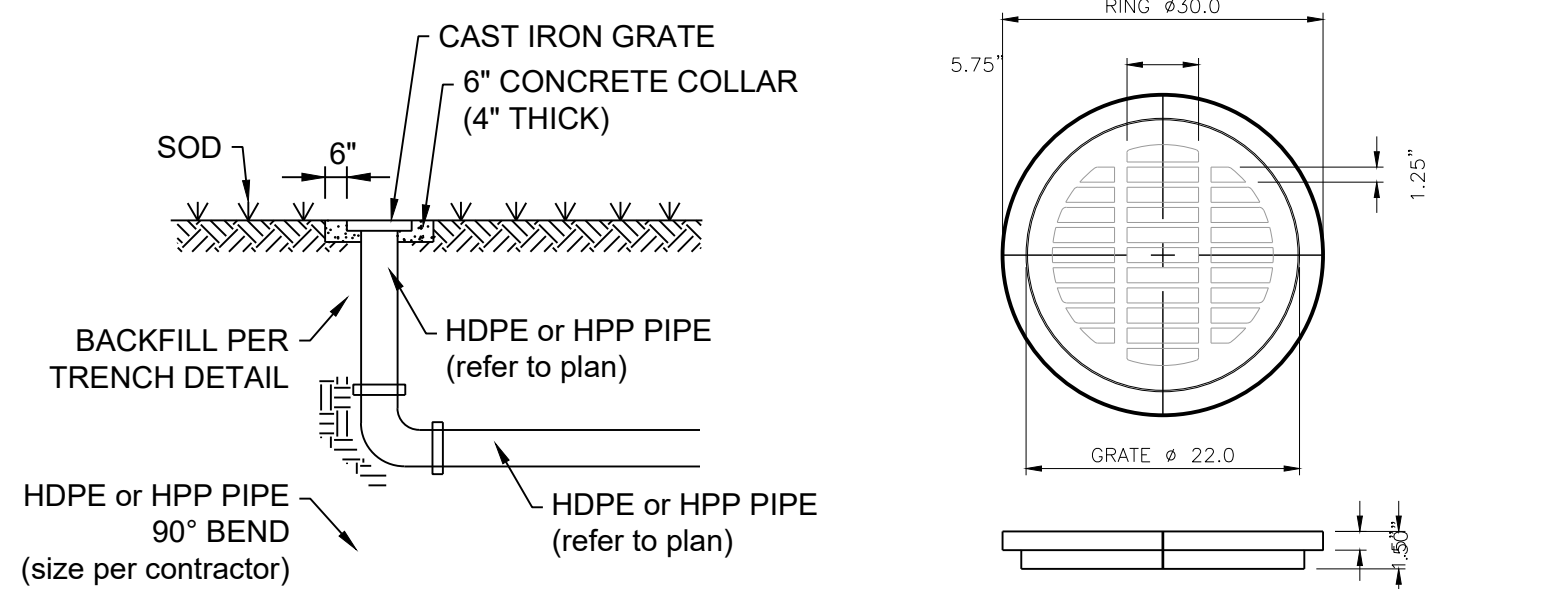

TYPICAL YARD DRAIN DETAIL

N.T.S.

STANDARD (H-20) RATED DRAINAREA = 161.4 SQ. INCH

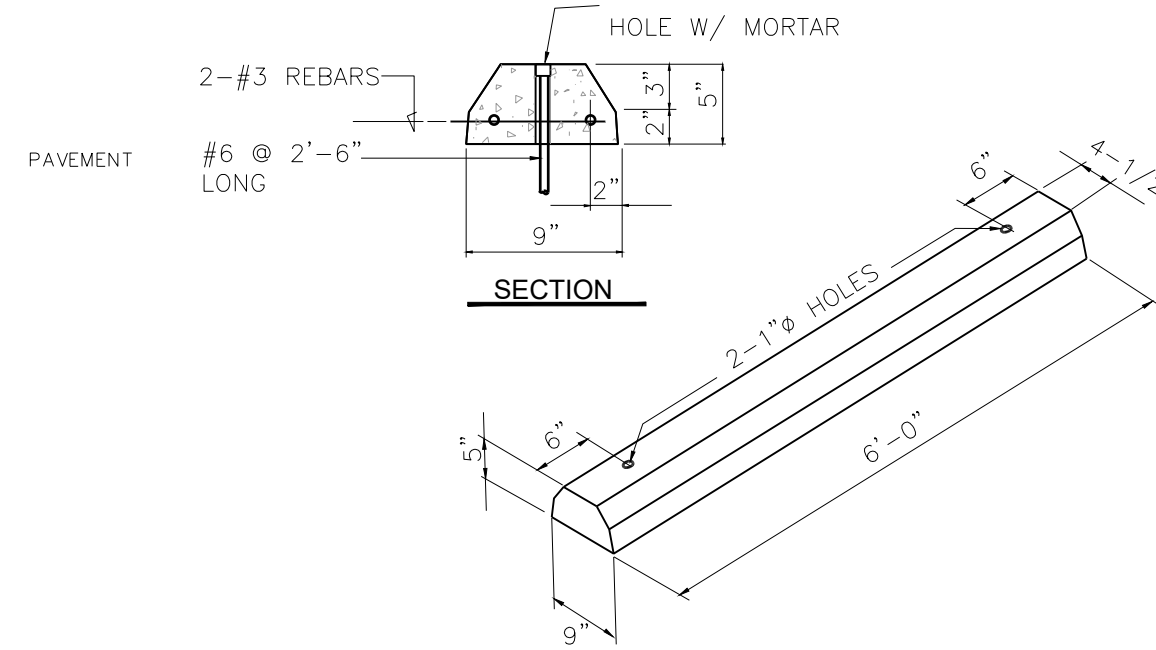

PRECAST CONCRETE WHEEL STOP DETAIL

N.T.S.

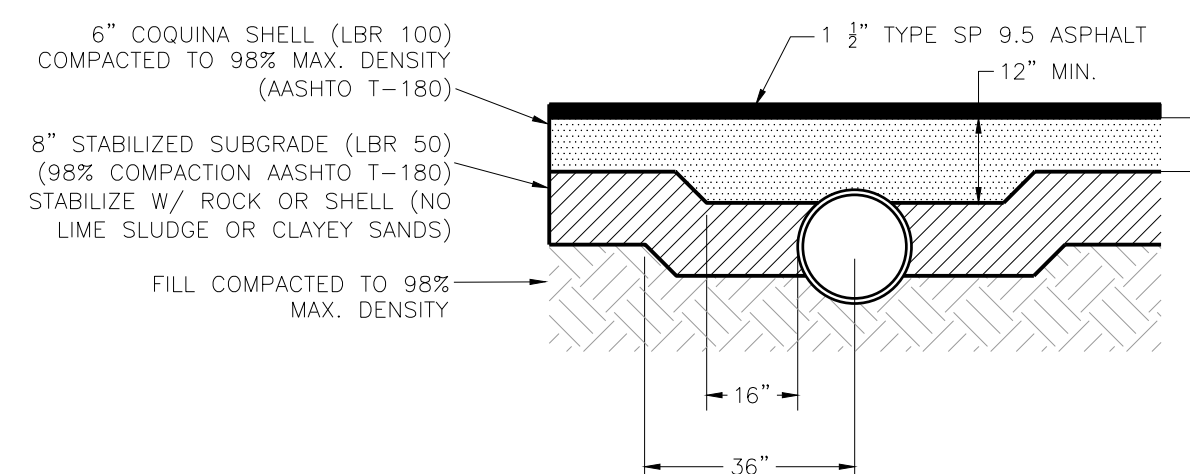

TYPICAL ASPHALTIC CONCRETE PAVING OVER DRAINAGE PIPES

N.T.S.

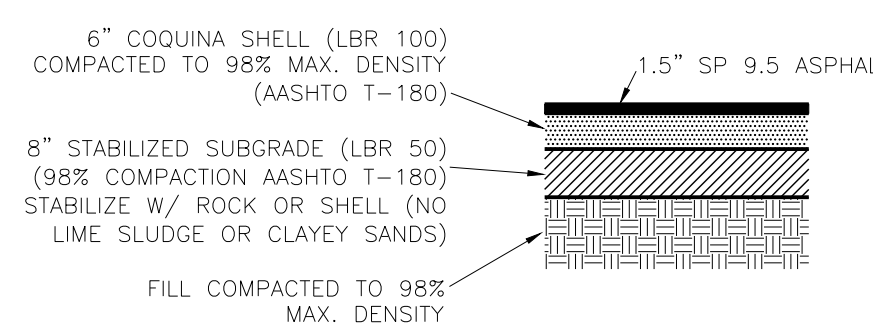

TYPICAL ASPHALTIC CONCRETE PAVING SECTION

N.T.S.

ASPHALTIC CONCRETE PAVING SECTION (within the FDOT/MC Right-of-Way)

N.T.S.

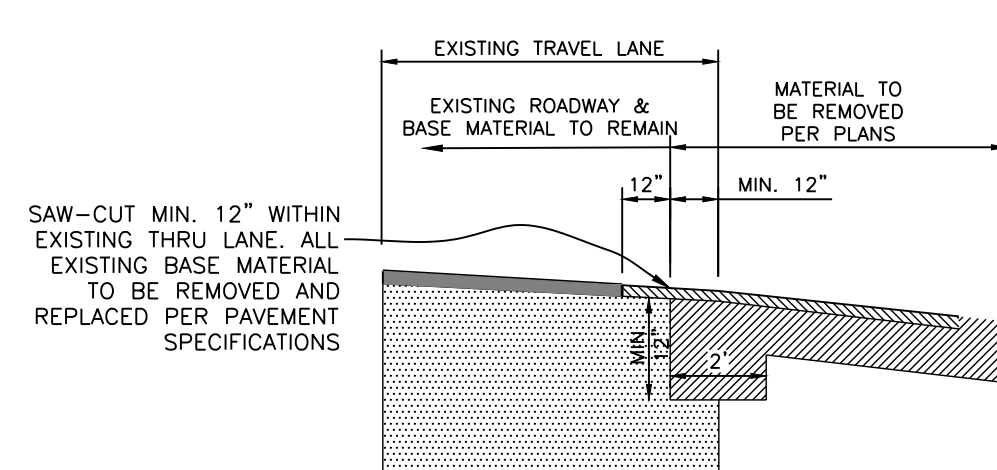

SAW CUT DETAIL

N.T.S.

NOTE: ALL NEW PAVEMENT JOINTS SHALL INCLUDE A MIN. 12" WIDE ASPHALT OVERLAY OVER EXISTING BASE AND A MIN. 12" DEEP BASE FOR THE FIRST 2 FEET OF NEW CONSTRUCTION.

NOTE: PARKING STALL WIDTHS SHALL BE DIMENSIONED FROM CENTERLINE TO CENTERLINE OF THE WHITE STRIPES. THIS APPLIES TO HANDICAP PARKING STALLS ALSO.

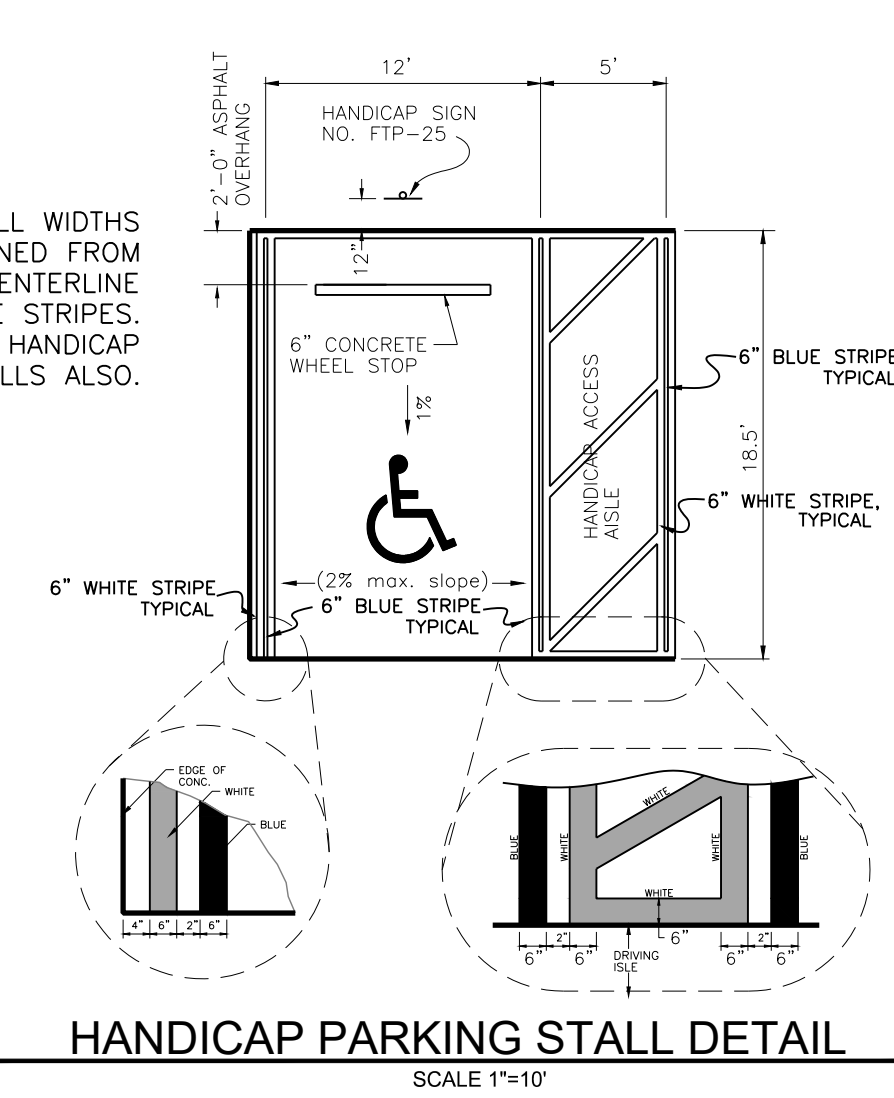

HANDICAP PARKING STALL DETAIL

SCALE 1"=10'

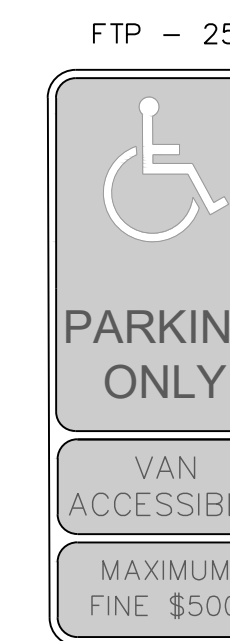

HANDICAP SIGNAGE & PAVEMENT SYMBOLS DETAIL

N.T.S.

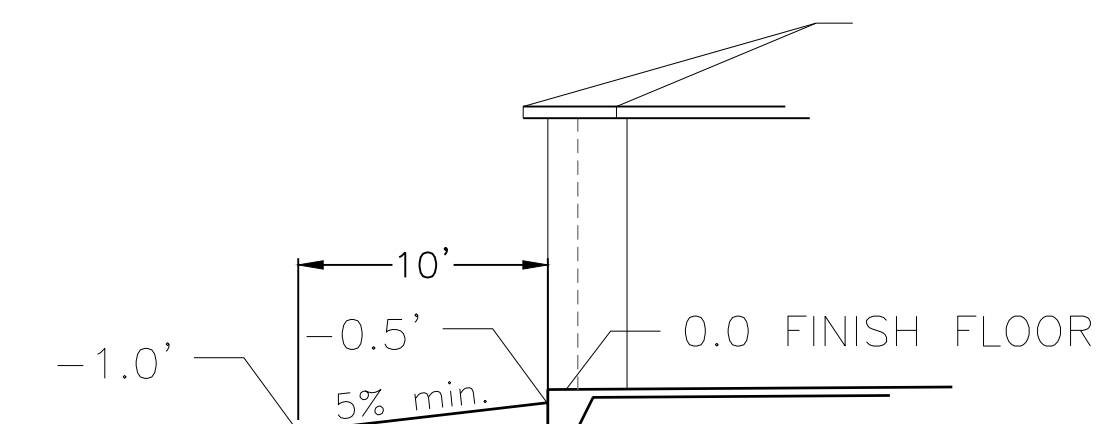

TYPICAL BUILDING GRADING

N.T.S.

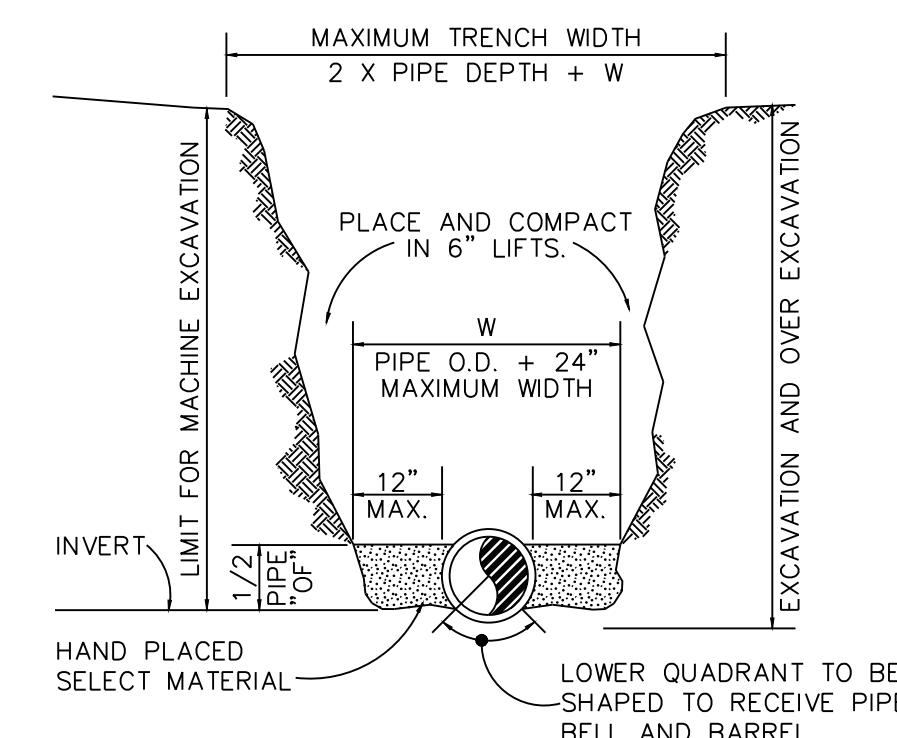

TYPICAL TRENCH DETAIL

N.T.S.

NOTE: ALL NEW PAVEMENT JOINTS SHALL INCLUDE A MIN. 12" WIDE ASPHALT OVERLAY OVER EXISTING BASE AND A MIN. 12" DEEP BASE FOR THE FIRST 2 FEET OF NEW CONSTRUCTION.

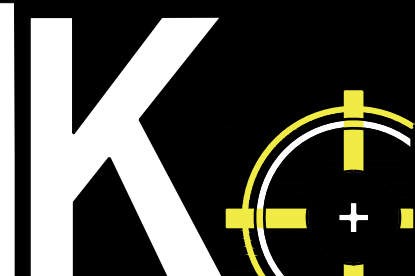

KMA
ENGINEERING & SURVEYING, LLC
2545 14TH AVE. SUITE #3
VERO BEACH, FL 32909
PHONE: (772) 588-5555
FAX: (772) 588-5555
E-MAIL: KMA@KMA-FL.COM

REVISIONS:	DATE:	BY:	COMMENT:

NOT FOR CONSTRUCTION

**HARSON WAREHOUSE
CONSULTANT GROUP
CONSTRUCTION PLAN**
FORT PIERCE, FLORIDA

**EAST COAST
CONSULTANT GROUP
LLC**
707 WEST BOULEVARD CHATELAINE
DELRAY BEACH, FL 33445

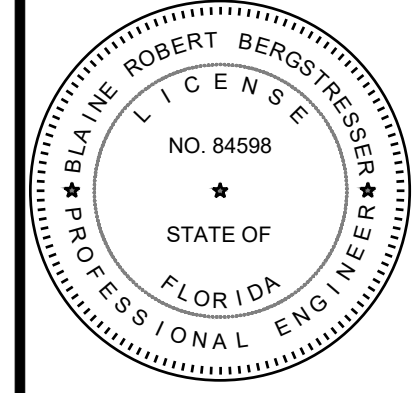

BLAINE BERGSTRESSER, P.E.
FLORIDA LICENSE NO. 84598
8/12/2024



PROJECT NO: 24-1004
DRAWN BY: SCB
CHECKED BY: BRB
DATE: 08/07/2024

DETAILS

SHEET NUMBER:
C-05

LINework & SYMBOL LEGEND

- DENOTES PROPERTY BOUNDARY
- DENOTES RIGHT-OF-WAY
- DENOTES CENTERLINE
- DENOTES EASEMENT/PARCEL
- DENOTES FENCE LINE
- DENOTES DITCH FLOW-LINE
- DENOTES WATER MAIN
- DENOTES FORCE MAIN
- DENOTES DRAINAGE PIPE
- DENOTES SEWER MANHOLE
- DENOTES FIRE HYDRANT
- DENOTES GATE VALVE
- DENOTES RUNOFF OVERLAND FLOW
- DENOTES PROPOSED ELEVATIONS
- DENOTES EXISTING GRADES
- DENOTES DRAINAGE STRUCTURE
- DENOTES YARD DRAIN
- DENOTES MITERED/FLARED END SECTION
- DENOTES FLARED END SECTION
- DENOTES LIGHT POLE
- DENOTES STREET SIGN



REVISIONS:	BY:	DATE:	COMMENT:

NOT FOR CONSTRUCTION

PROJECT:
HARSON WAREHOUSE
CONSTRUCTION PLAN
FORT PIERCE, FLORIDA

CLIENT:
EAST COAST
CONSULTANT GROUP
LLC
707 WEST BOULEVARD CHATELAINE
DELRAY BEACH, FL 33445

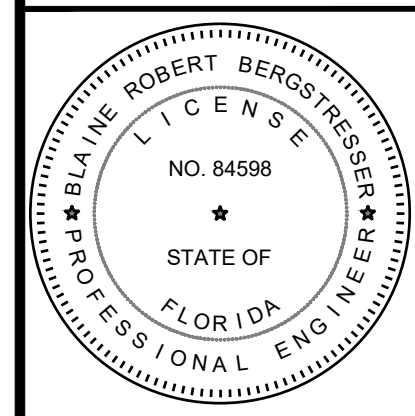

BLAINE BERGSTRESSER, P.E.
FLORIDA LICENSE No. 84598
8/12/2024

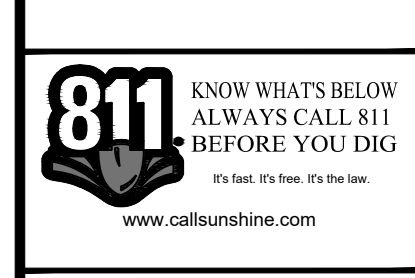

PROJECT No.: 24-1004
DRAWN BY: SCB
CHECKED BY: BRB
DATE: 08/07/2024

SHEET TITLE:
UTILITIES

SHEET NUMBER:
C-06

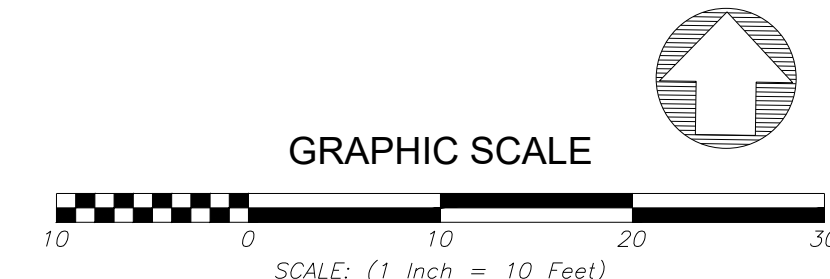
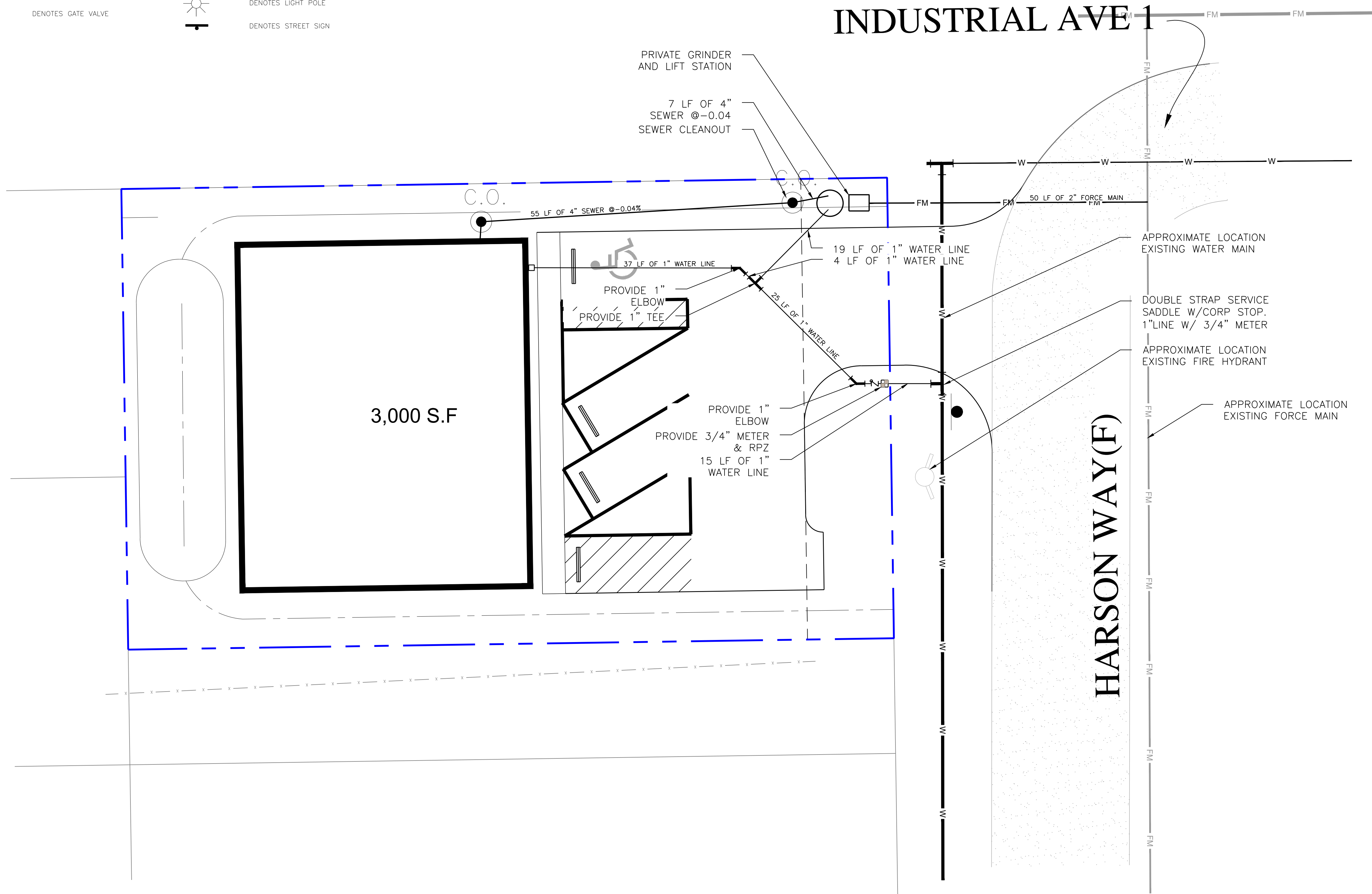

NAVD 1988
ALL ELEVATIONS DEPICTED HEREON
REFERENCE NAVD 1988. THE CONVERSION
FACTOR TO NGVD 1929 IS +1.496'

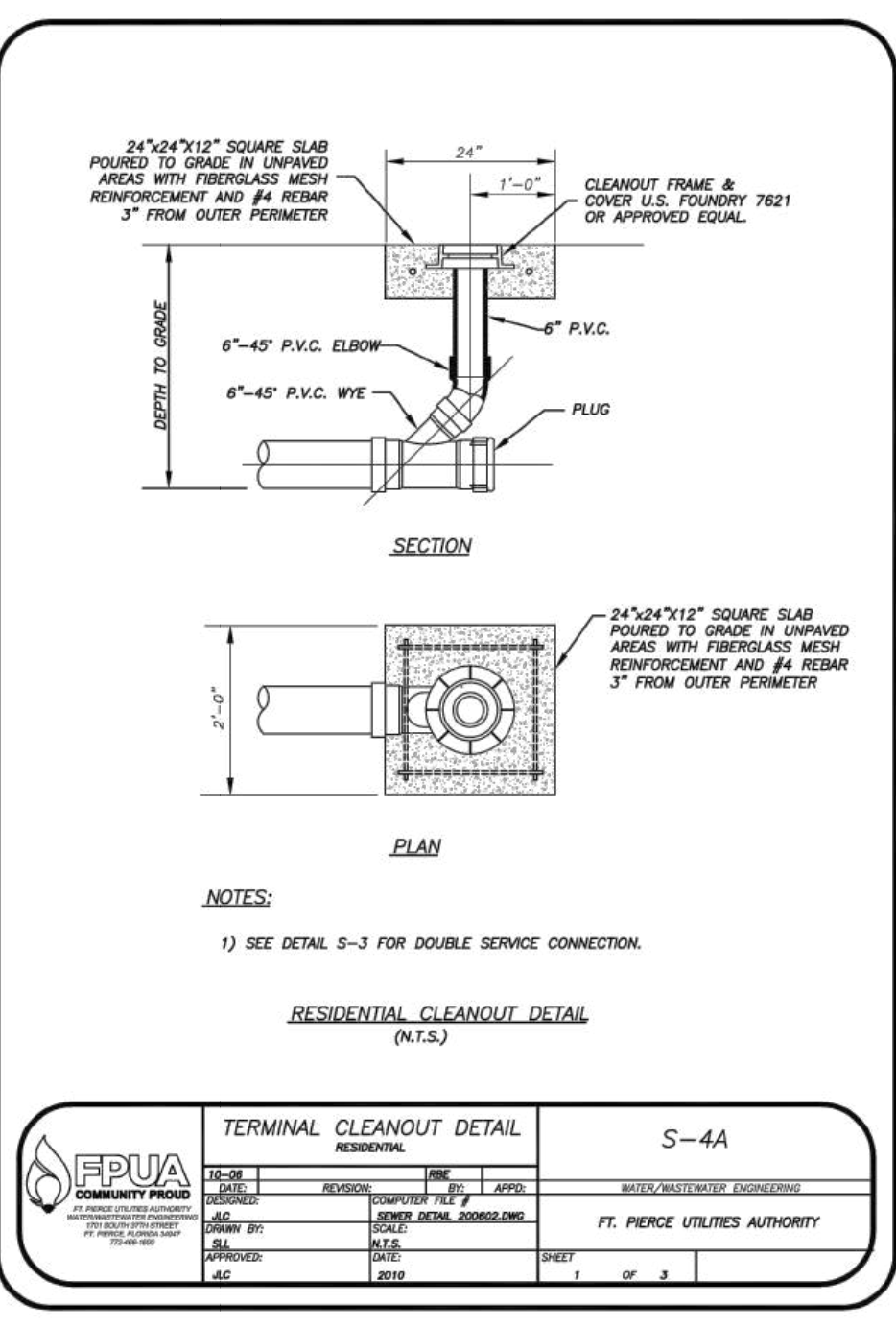

TERMINAL CLEANOUT DETAIL		S-4A	
DATE	REVISION	BY	APP'D.
08/07/2024	ISSUED FOR PERMIT	SCB	
08/07/2024	DESIGN	BRB	
08/07/2024	CHECKED	BRB	
08/07/2024	DATE	SCALE	SHEET
08/07/2024	2024	1/8" = 1'-0"	1 OF 3

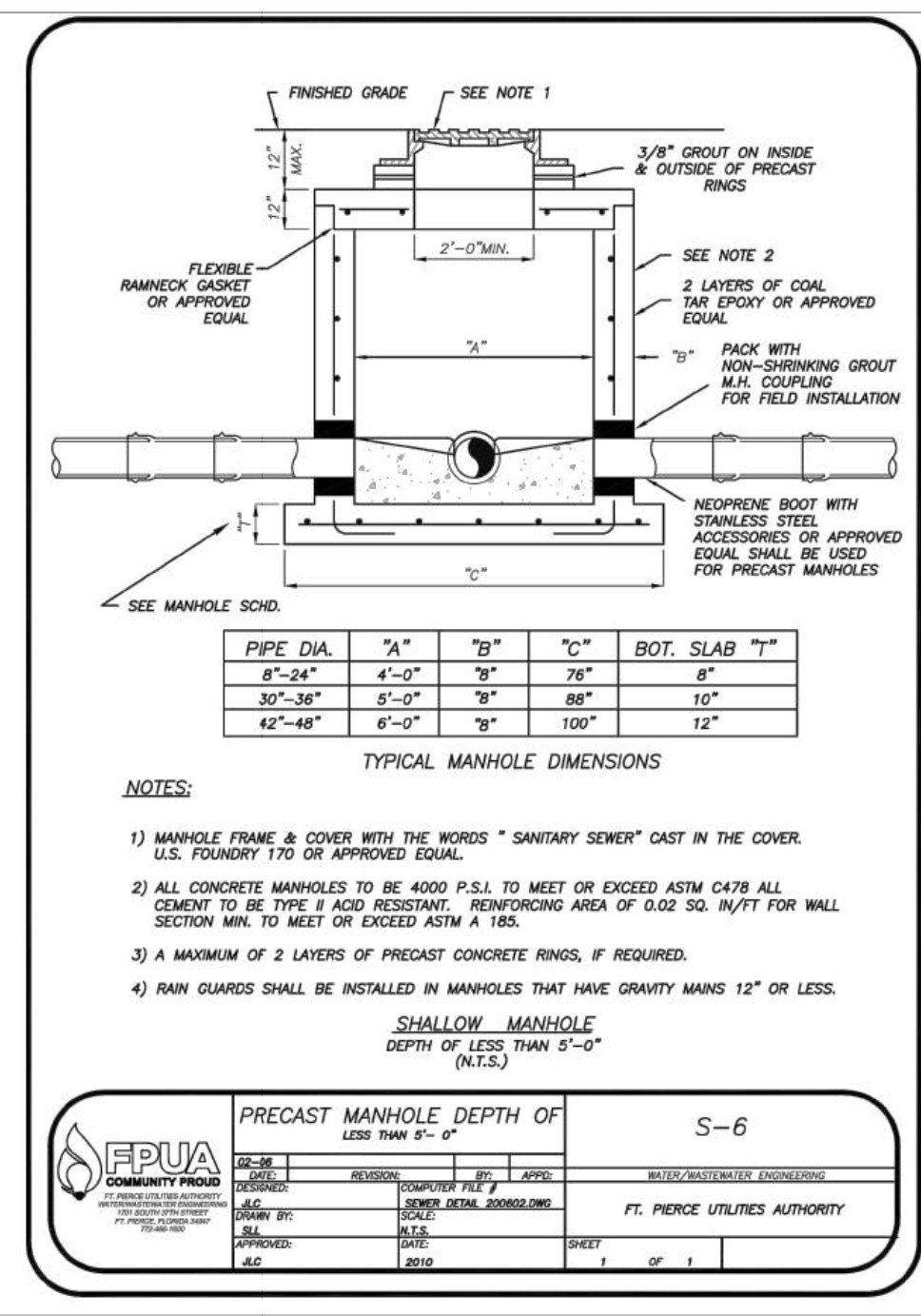

PRECAST MANHOLE DEPTH OF		S-6	
DATE	REVISION	BY	APP'D.
08/07/2024	ISSUED FOR PERMIT	SCB	
08/07/2024	DESIGN	BRB	
08/07/2024	CHECKED	BRB	
08/07/2024	DATE	SCALE	SHEET
08/07/2024	2024	1/8" = 1'-0"	1 OF 1

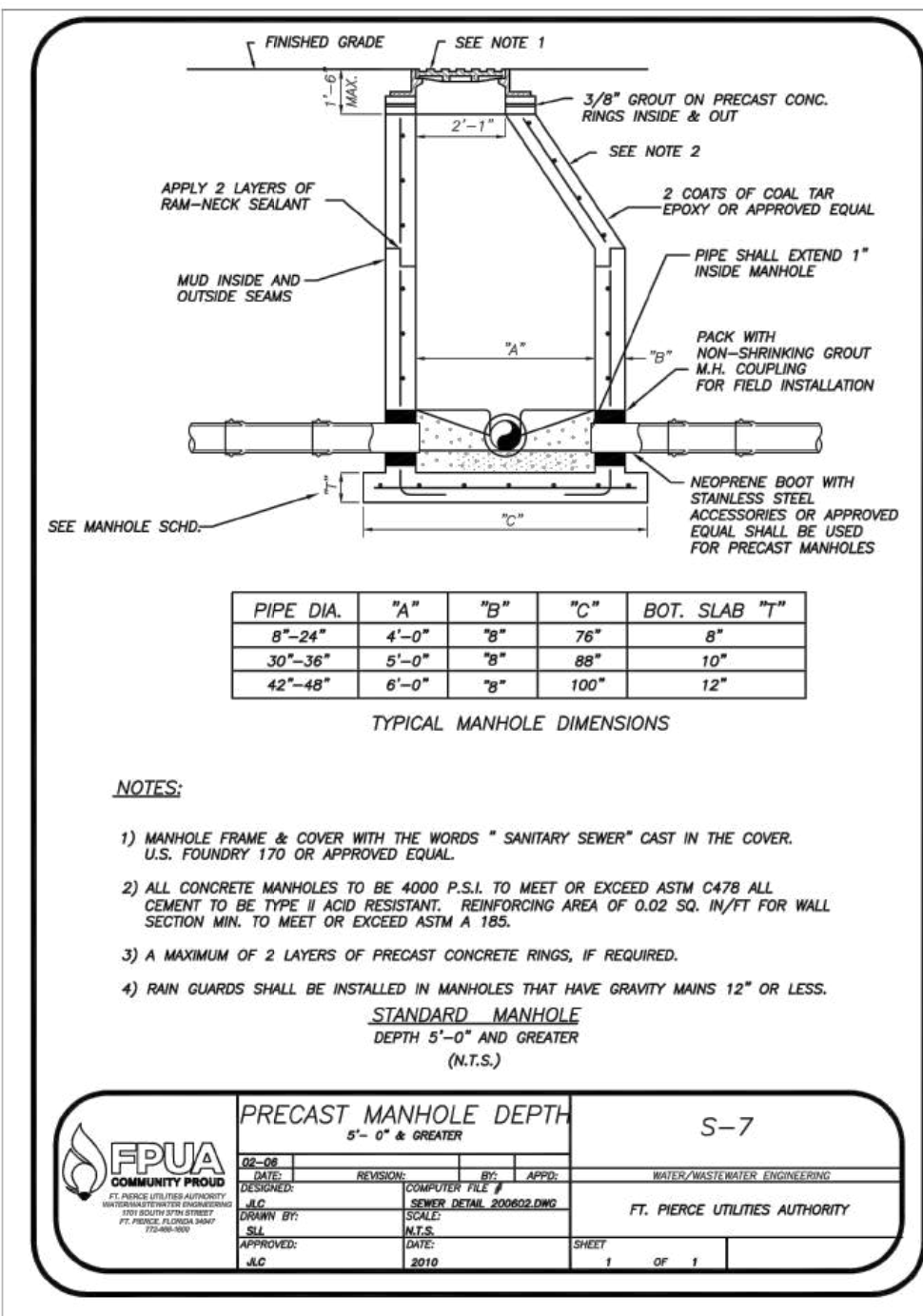

PRECAST MANHOLE DEPTH		S-7	
DATE	REVISION	BY	APP'D.
08/07/2024	ISSUED FOR PERMIT	SCB	
08/07/2024	DESIGN	BRB	
08/07/2024	CHECKED	BRB	
08/07/2024	DATE	SCALE	SHEET
08/07/2024	2024	1/8" = 1'-0"	1 OF 1

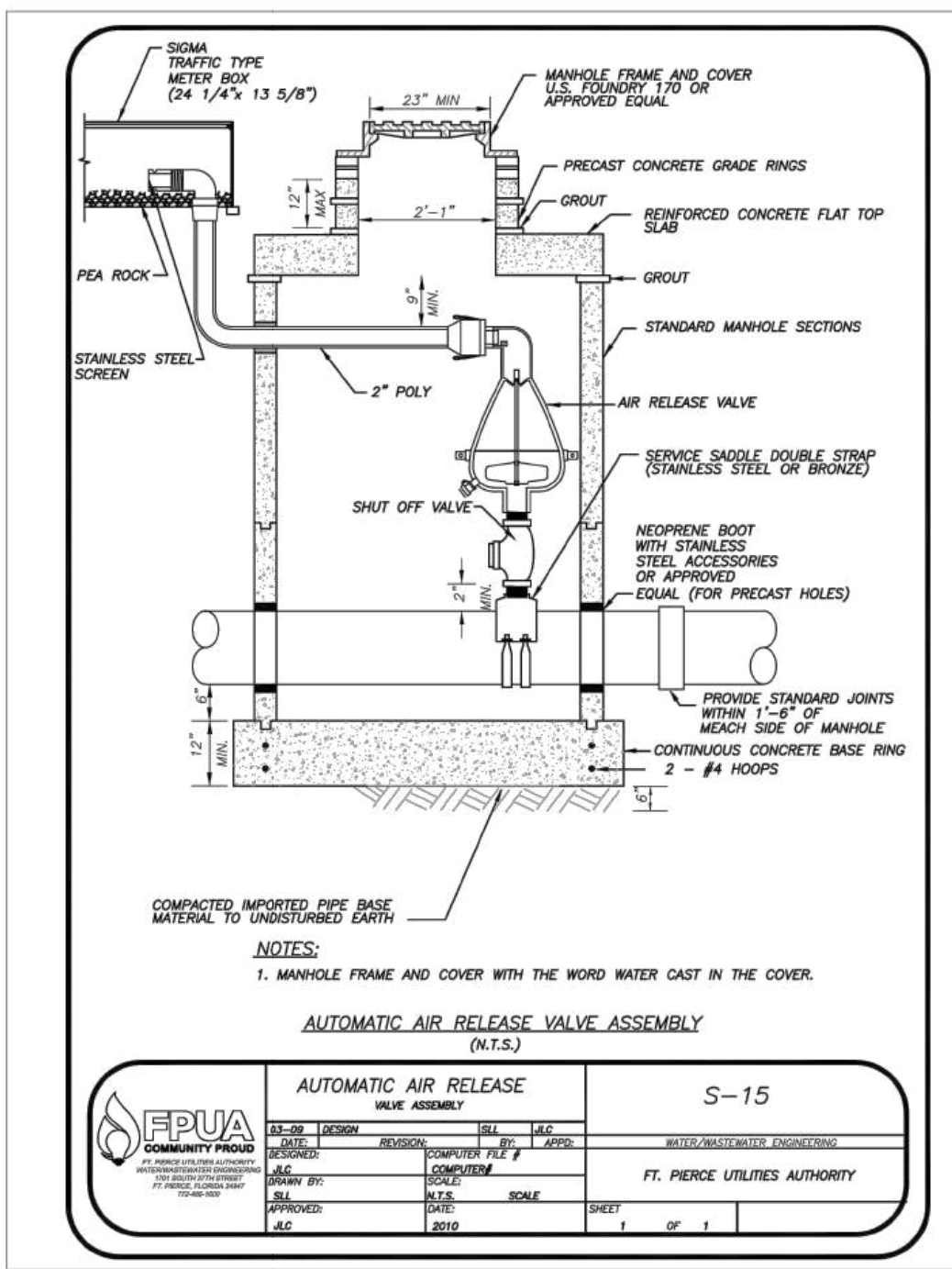

AUTOMATIC AIR RELEASE		S-15	
DATE	REVISION	BY	APP'D.
08/07/2024	ISSUED FOR PERMIT	SCB	
08/07/2024	DESIGN	BRB	
08/07/2024	CHECKED	BRB	
08/07/2024	DATE	SCALE	SHEET
08/07/2024	2024	1/8" = 1'-0"	1 OF 1

KMA
ENGINEERING & SURVEYING, LLC
2345 14TH AVE. SUITE #3
VERO BEACH, FL 33560
PHONE: (772) 588-5555
FAX: (772) 588-5555
E-MAIL: KMA@KMA-ES.COM

REVISIONS:
BY: DATE:

COMMENT:

NOT FOR CONSTRUCTION

PROJECT:
**HARSON WAREHOUSE
CONSTRUCTION PLAN**
FORT PIERCE, FLORIDA

CLIENT:
**EAST COAST
CONSULTANT GROUP
LLC**
707 WEST BOULEVARD CHATELAINE
DELRAY BEACH, FL 33445

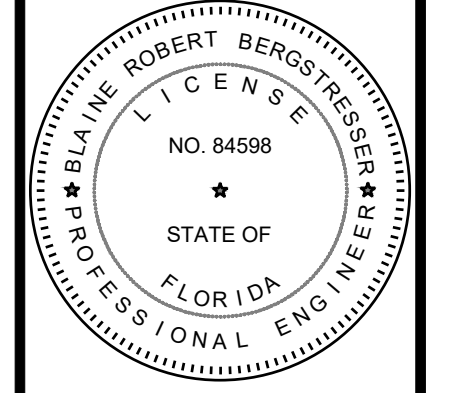

BLAINE BERGSTRESSER, P.E.
FLORIDA LICENSE No. 84598
8/12/2024



PROJECT No.: 24-1004
DRAWN BY: SCB
CHECKED BY: BRB
DATE: 08/07/2024

SHEET TITLE:
FPUA DETAILS-02

SHEET NUMBER:
C-08