

FOR LEASE

RETAIL | \$14/SF NNN | 1,500 - 20,000 SF

MAJOR RENOVATIONS UNDERWAY!

9797 W. COLFAX AVE LAKEWOOD, CO 80215



COLFAX KIPLING CENTER



15000 W 44TH AVE. SUITE C GOLDEN, CO 80403
720.843.1330 | WWW.DIGBYCOMMERCIAL.COM

LEAD CONTACT

Lucas Quinn

Associate Broker

720.843.1330 Ext. 106

978.460.5577

Lucas@DigbyCommercial.com

Tanner Digby, SIOR

President

720.843.1330 Ext. 104

720.402.7578

Tanner@DigbyCommercial.com

PROPERTY INFORMATION

COLFAX KIPLING CENTER

9797 W. COLFAX AVE

LAKEWOOD, CO 80215



LEASE RATE	\$14/SF NNN
OP. EX.	CONTACT BROKER
LEASE TERMS	3-5 YEARS
YEAR BUILT/RENO	1973/2026
BUILDING SIZE	43,200 SF (TBV)
TOTAL SF. AVAIL.	1,500-20,000
UNITS	3 AVAILABLE
LOT SIZE	4.43 AC
USE	RETAIL
ZONING	M-G-S (LAKEWOOD)
PARKING	5.51 1,000

*ALL AVAILABLE UNITS WILL BE DELIVERED IN WHITE BOX CONDITION, RENDERED PHOTOS ARE FOR VISUALIZATION PURPOSES ONLY AND DO NOT REFLECT EXISTING BUILD-OUT

PROPERTY HIGHLIGHTS

- Prime retail space with high visibility
- Highly divisible suites from 1,500 SF up to 20,000 SF
- Located along major thoroughfare at Kipling & Colfax
- Strong traffic counts and exposure
- Tenant improvement (TI) packages offered
- White box unit delivery



RENOVATIONS UNDERWAY:

- ✓ NEW ROOF
- ✓ NEW PARKING LOT AND SIDEWALKS
- ✓ NEW MONUMENT SIGN
- ✓ WHITE BOX UNIT DELIVERY

AVAILABLE SPACES

COLFAX KIPLING CENTER

9797 W. COLFAX AVE

LAKEWOOD, CO 80215

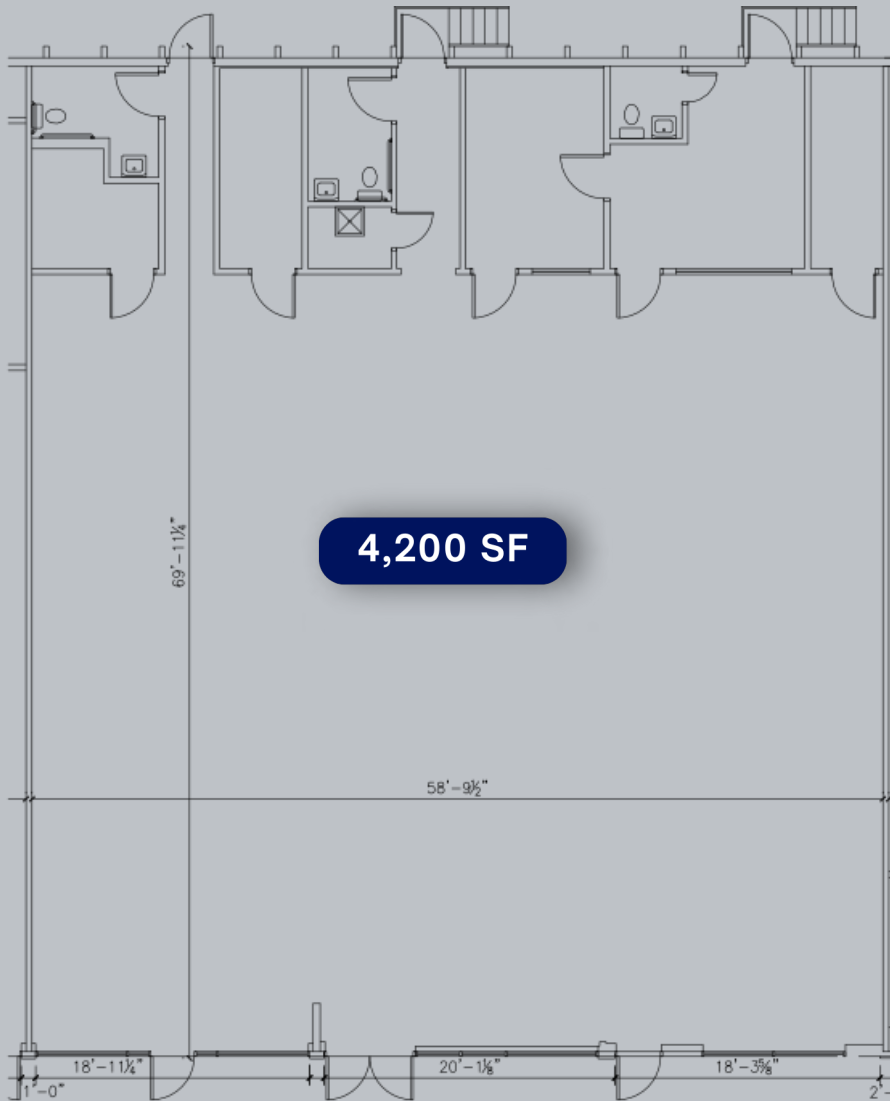

4,200 SF

TOTAL: 4200 SF-Vacant

9797 W Colfax Ave
Lakewood CO 80215

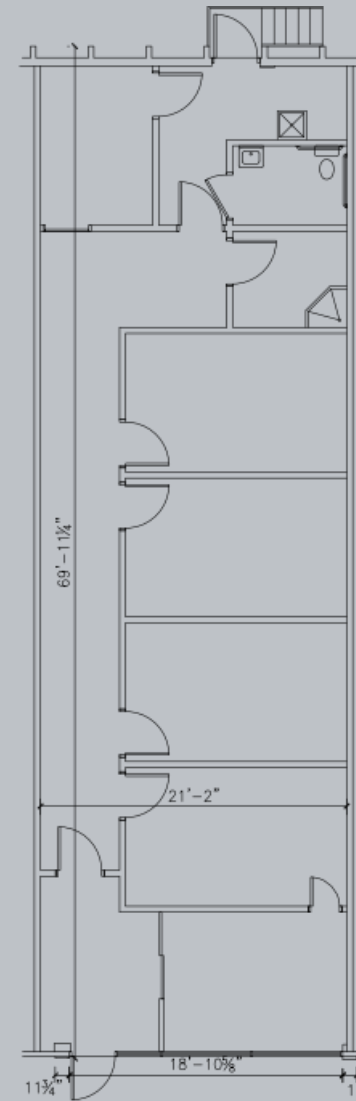
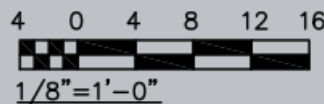

1,523 SF

TOTAL: 1,523 SF-vacant

9797 W Colfax Ave
Lakewood CO 80215

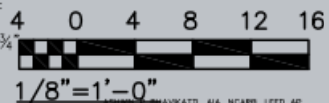

ABHIJIT BHAVIKATTI, AIA, NCARB, LEED AP
BHAVIKATTI ARCHITECTURE LLC
6924 E HERITAGE PLACE NORTH
DENVER, CO 80111
Phone: 720-221-8500 Fax: 720-747-1796
Email: abhavikatti@bhavattiarch.com

AVAILABLE SPACES COLFAX KIPLING CENTER

9797 W. COLFAX AVE
LAKEWOOD, CO 80215

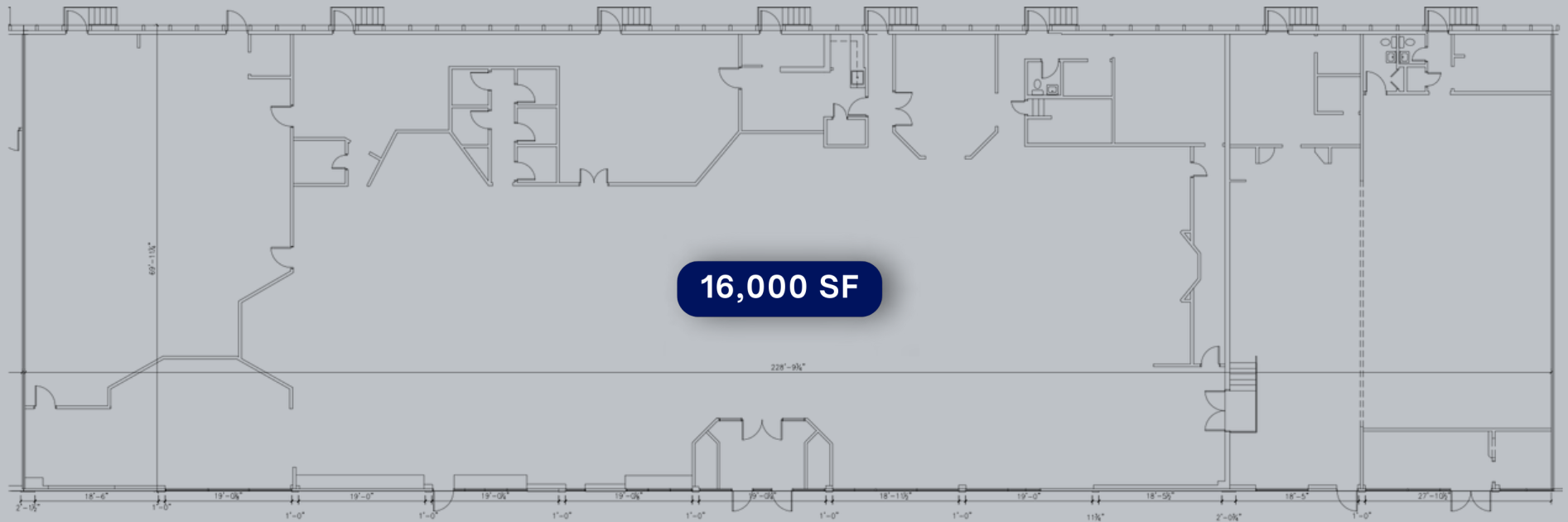

LARGE UNIT DEPICTED ABOVE IS DEMISABLE AS LITTLE AS 2,000 SF:

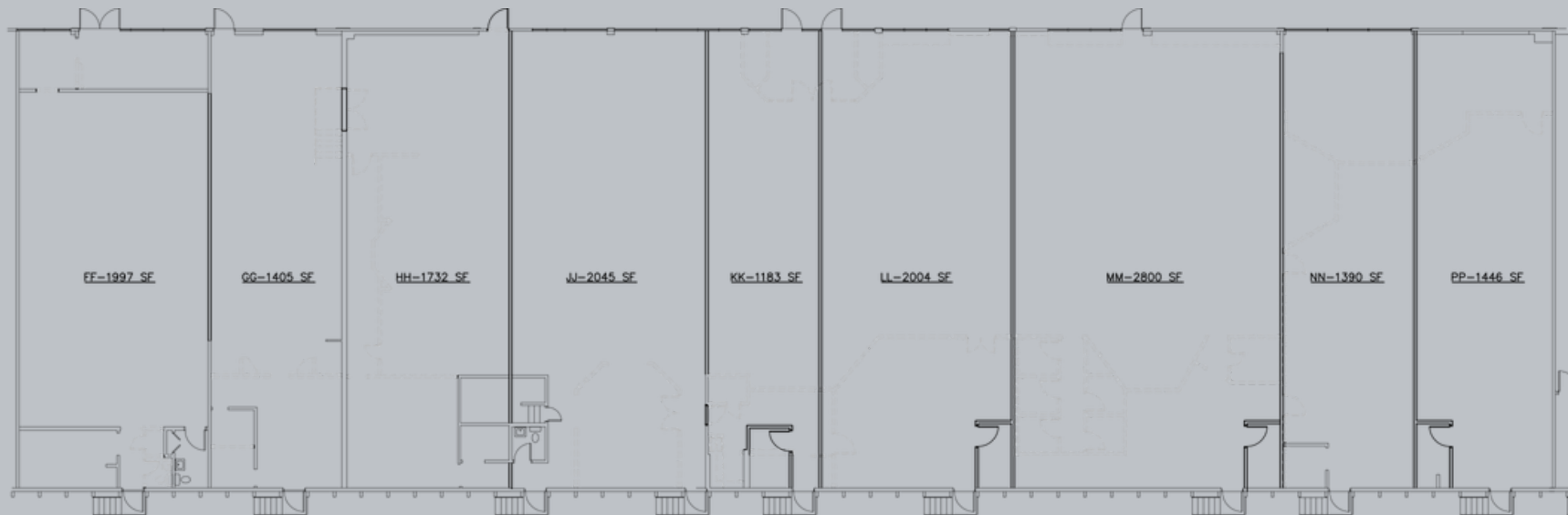

SITE PLAN / TENANT MIX COLFAX KIPLING CENTER

9797 W. COLFAX AVE
LAKEWOOD, CO 80215

*ALL AVAILABLE UNITS WILL BE DELIVERED IN WHITE BOX CONDITION, LARGEST SPACE DEMISABLE AS LITTLE AS 2,000 SF

KIPLING ST 36,638 VPD



IRIS ST

W. COLFAX AVE 35,738 VPD

*SITE PLAN IS FOR ILLUSTRATIVE PURPOSES ONLY AND IS NOT GUARANTEED TO BE TO SCALE. INTENDED SOLELY FOR TENANT VISUALIZATION AND GENERAL REFERENCE.

ADDITIONAL PHOTOS COLFAX KIPLING CENTER

9797 W. COLFAX AVE
LAKEWOOD, CO 80215



TRAFFIC & DEMOGRAPHICS

COLFAX KIPLING CENTER

9797 W. COLFAX AVE
LAKEWOOD, CO 80215



RADIUS	2-MILE	5-MILE	10-MILE
2025 POPULATION	42,396	318,648	1,074,587
2030 PROJECTED	43,196	324,832	1,089,045
AVG. HOUSEHOLD INCOME	\$107,288	\$118,465	\$126,611
MEDIAN HOME VALUE	\$674,393	\$662,915	\$673,652

*DEMOGRAPHIC DATA HAS BEEN PROVIDED BY COSTAR GROUP AND IS DEEMED RELIABLE BUT HAS NOT BEEN VERIFIED FOR ACCURACY OR COMPLETENESS.

LOCATION MAP

COLFAX KIPLING CENTER

9797 W. COLFAX AVE
LAKEWOOD, CO 80215

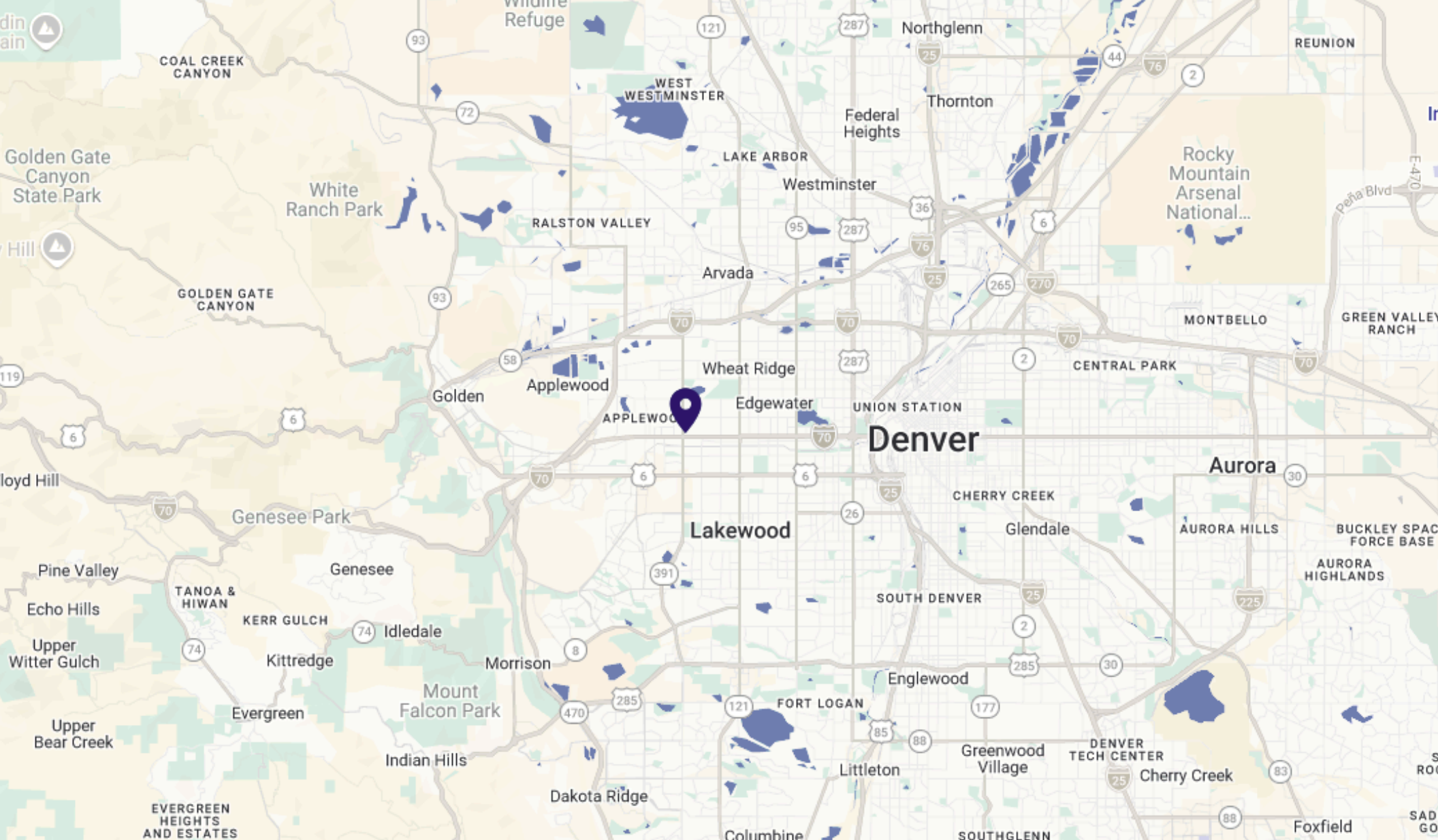

COPYRIGHT © 2026 DIGBY COMMERCIAL ADVISORS. ALL INFORMATION CONTAINED HEREIN HAS BEEN OBTAINED FROM SOURCES BELIEVED TO BE RELIABLE BUT IS NOT GUARANTEED AS TO ACCURACY OR COMPLETENESS. ANY RELIANCE ON THIS INFORMATION IS AT YOUR OWN RISK. ALL PHOTOGRAPHS, IMAGES, AND MARKETING MATERIALS ARE THE PROPERTY OF DIGBY COMMERCIAL ADVISORS AND MAY NOT BE COPIED, REPRODUCED, OR DISTRIBUTED WITHOUT PRIOR WRITTEN PERMISSION.

720.843.1330 | 15000 W 44TH AVE. SUITE C, GOLDEN, CO 80403 | WWW.DIGBYCOMMERCIAL.COM