

BROADWAY TRADE CENTER

9929 BROADWAY STREET | SAN ANTONIO, TX 78217

FOR LEASE

2 Months Free Base Rent
on 3 year term for
spaces <3,000 SF
leased in the next 60 Days

For More
Information
Contact

Justin Roberts

Vice President

+1 210 841 3228

justin.roberts@cbre.com

Brad O'Neill

Vice President

+1 210 253 6070

brad.oneill@cbre.com

 ENTRADA
PARTNERS

CBRE

Property Overview

MOVE-IN READY CONDITION

AVAILABILITY

- ±203,651 Total SF
- Range of sizes available: ±1,232 SF - ±9,704 SF

BUILDING FEATURES

- 20' clear height
- Grade level and dock high loading

HVAC

- Landlord assumes all HVAC responsibility: \$0.40 PSF

TERMS

- Lease Rate: \$13.00-\$13.50 PSF
- Annual OPEX: \$5.36 PSF



LOCATION OVERVIEW

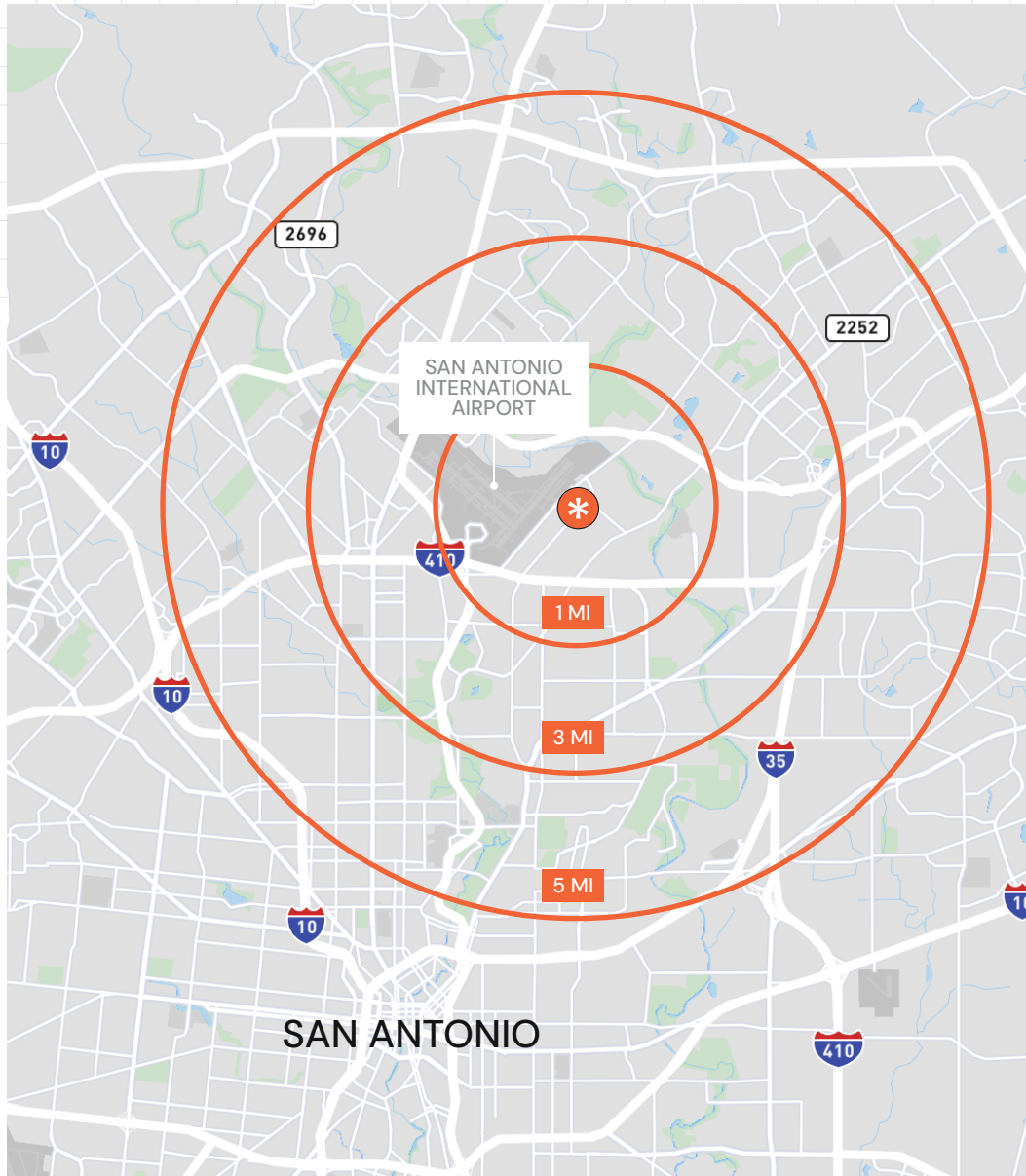

DEMOGRAPHICS

	1 Mile	3 Miles	5 Miles
2025 Population	6,117	83,663	261,616
2025 Employees	13,543	85,602	179,796
2025 Businesses	1,112	7,577	16,422
2025 Average Household Income	\$81,591	\$101,242	\$103,831
2025 Daytime Population	17,251	145,331	351,971



SITE MAP

AVAILABLE
 LEASED

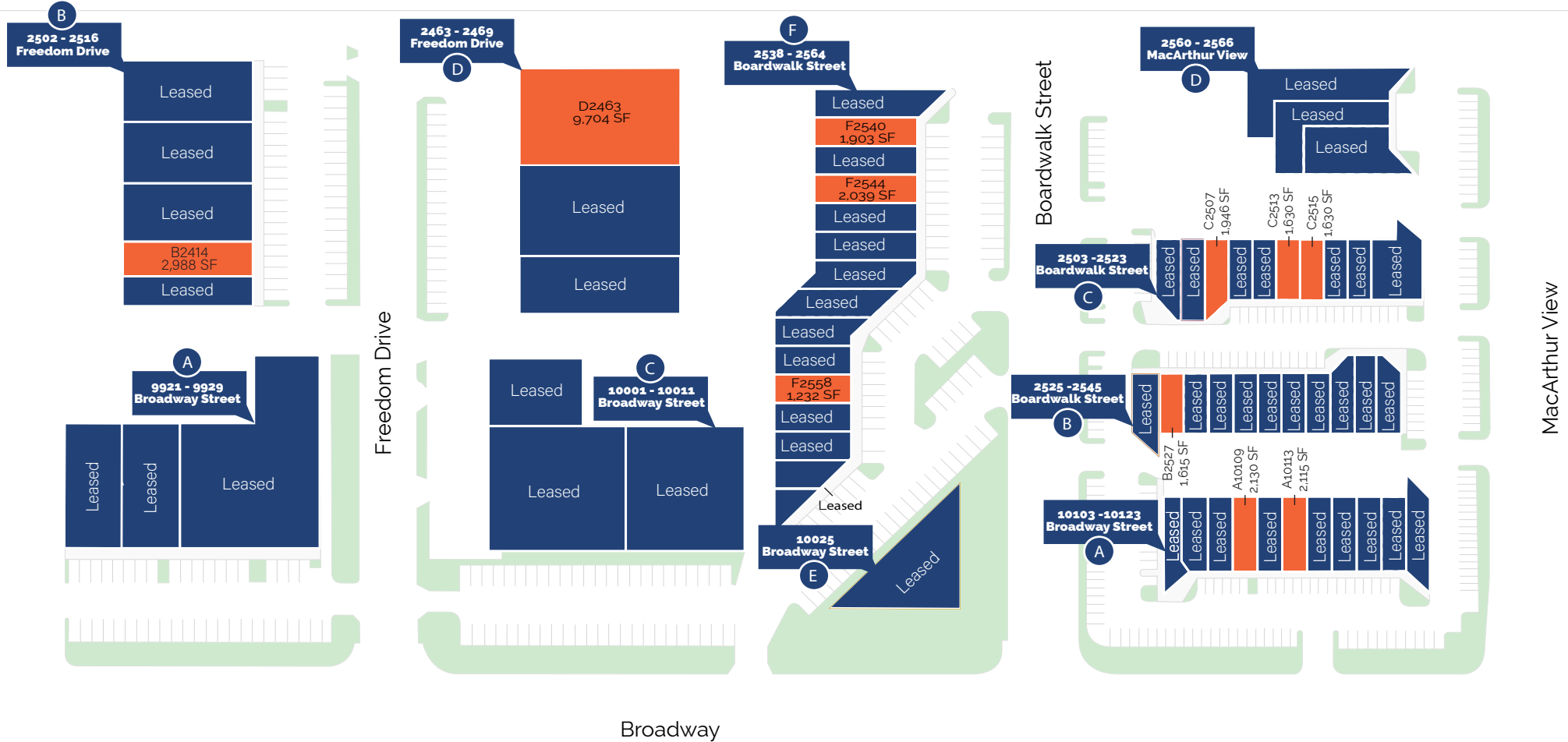

BLDG A

10103 – 10123

SUITE	A10109
SF	±2,130 SF
RATE	\$14.00 NNN
BUILD OUT	Contact Broker
LOADING	1 Dock Door
COMMENTS	Available 6/1/2026

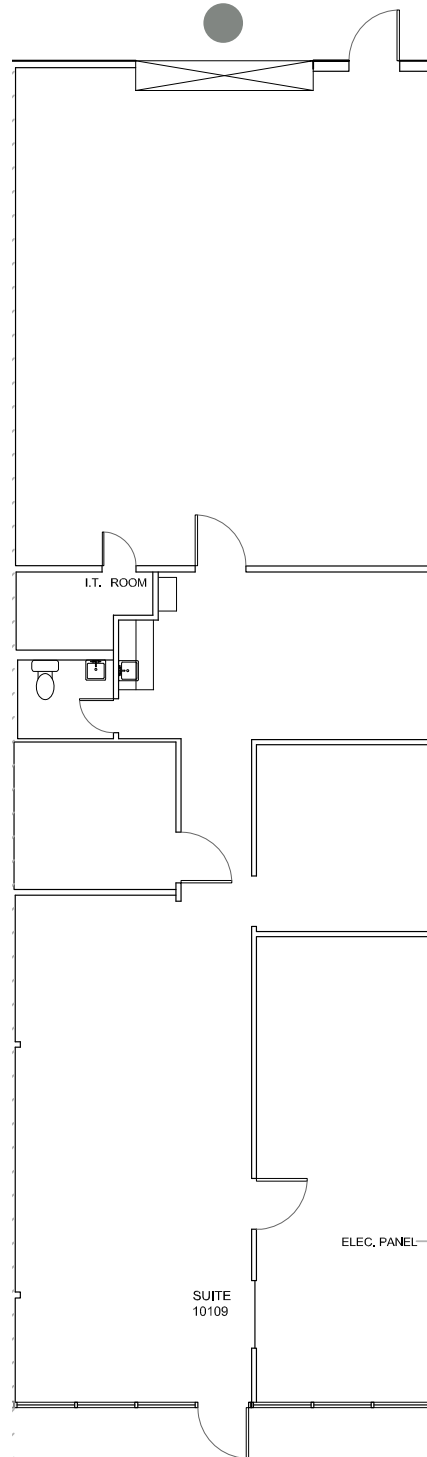

BLDG A

10103 – 10123

SUITE	A10113
SF	±2,115 SF
RATE	\$13.50 NNN
BUILD OUT	Contact Broker
LOADING	1 Grade Level Door
COMMENTS	Available Now

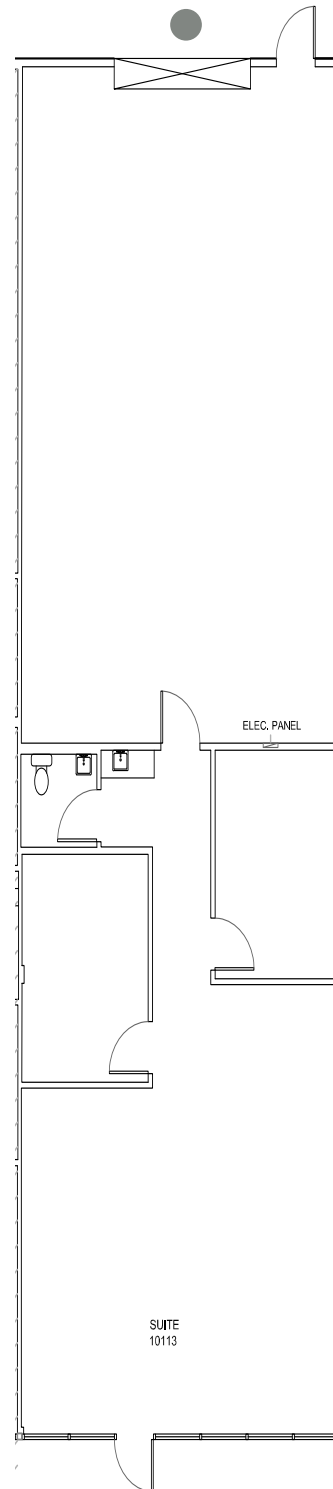

BLDG B

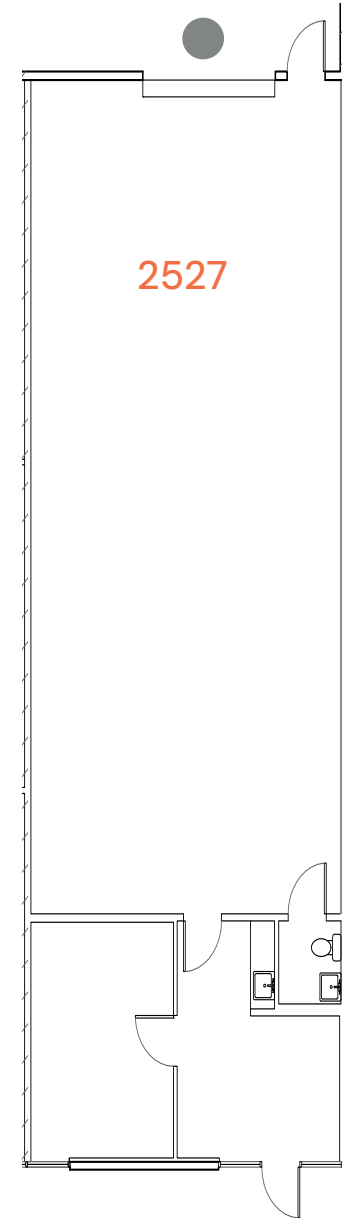
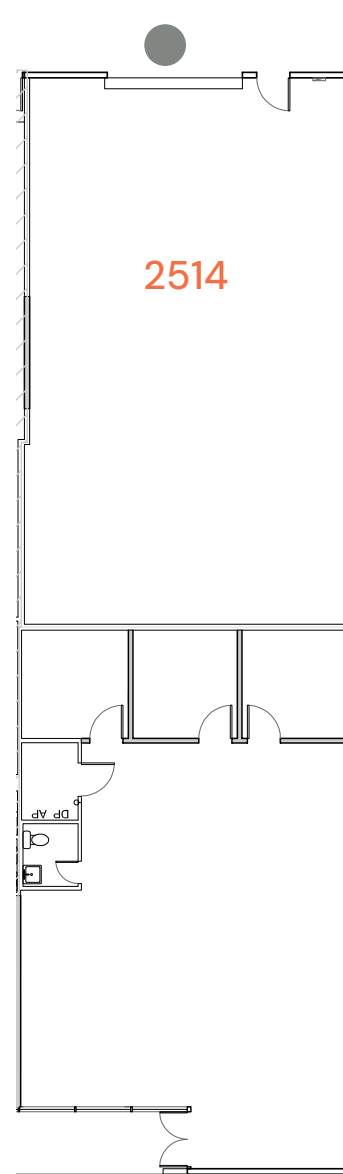

SUITE	B2514	B2527
SF	±2,988 SF	±1,615 SF
RATE	\$13.00 NNN	\$13.50 NNN
BUILD OUT	Office: 1,498 SF Warehouse: 1,490 SF	Office: 371 SF Warehouse: 1,244 SF
LOADING	1 Grade Level Door	1 Grade Level Door
COMMENTS	Available Now	Available Now

BLDG C

2503 - 2523

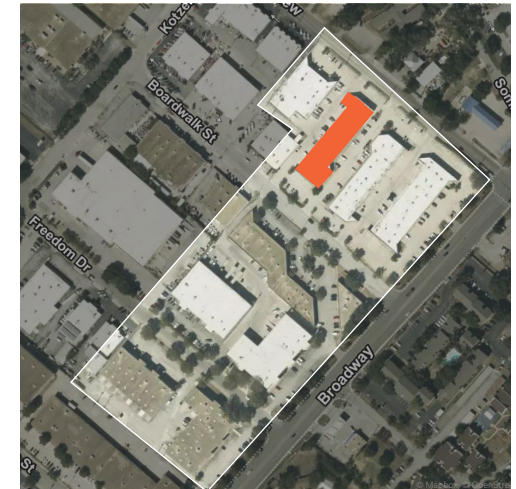
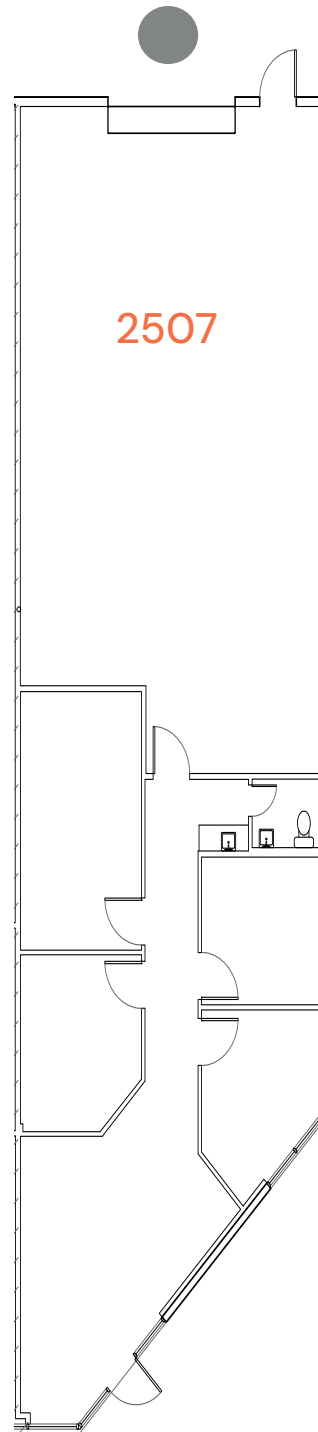

SUITE	C2507
SF	±1,946 SF
RATE	\$13.50 NNN
BUILD OUT	Office: 911 SF Warehouse: 1,035 SF
LOADING	1 Grade Level Door
COMMENTS	Available Now

BLDG C

2503 - 2523

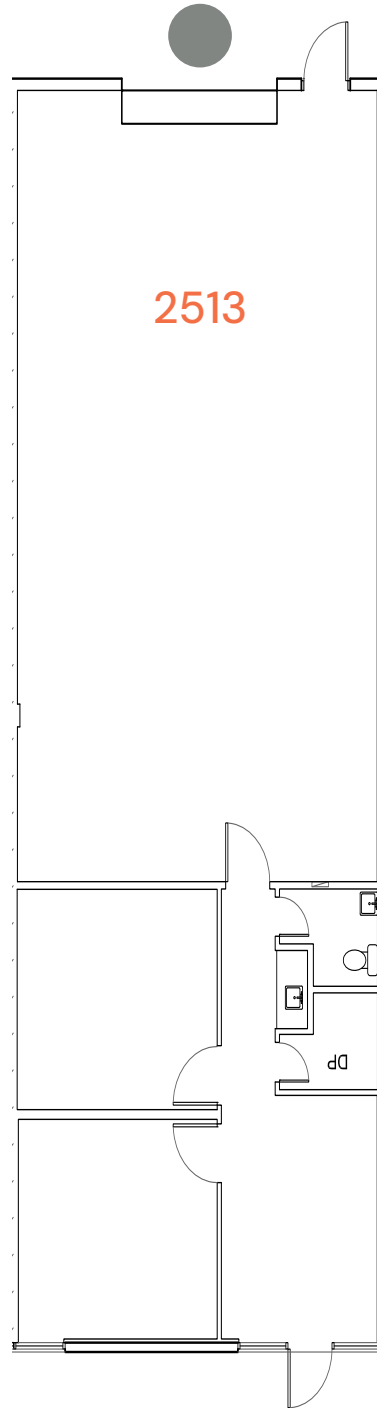

Contiguous Option: ±3,273 SF

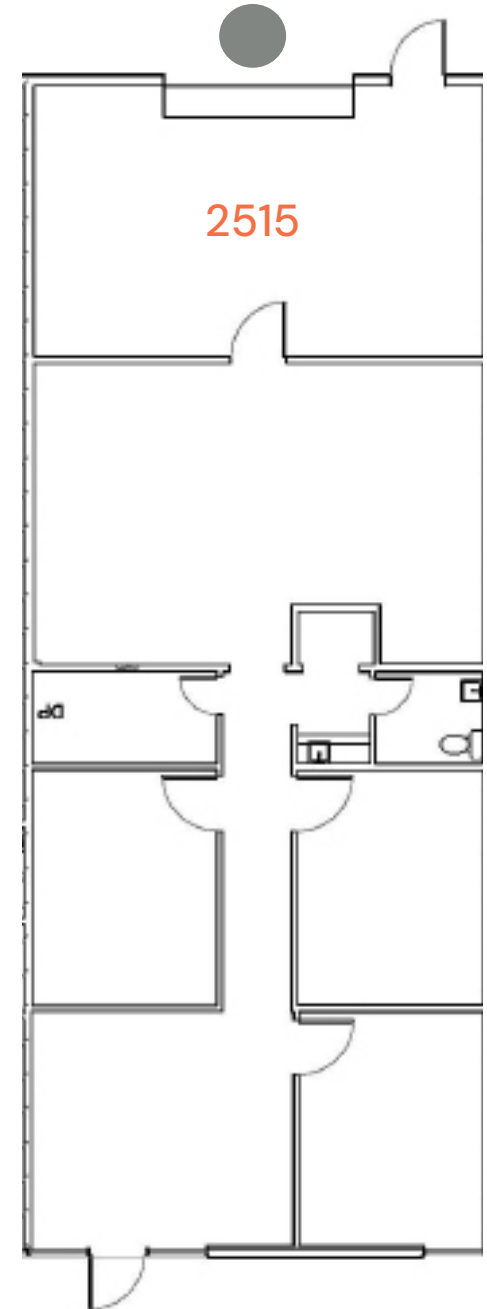

SUITE	C2513	C2515
SF	±1,630 SF	±1,643 SF
RATE	\$13.50 NNN	\$13.50 NNN
BUILD OUT	Office: 597 SF Warehouse: 1,033 SF	Office: 1,247 SF Warehouse: 396 SF
LOADING	1 Grade Level Door	1 Grade Level Door
COMMENTS	Available Now	Available Now

BLDG D

2463 - 2469



SUITE	D2463
SF	±9,704 SF
RATE	Contact Broker
BUILD OUT	±3,867 SF Office ±5,837 SF Warehouse
LOADING	3 Dock High Doors
COMMENTS	30 Days Notice

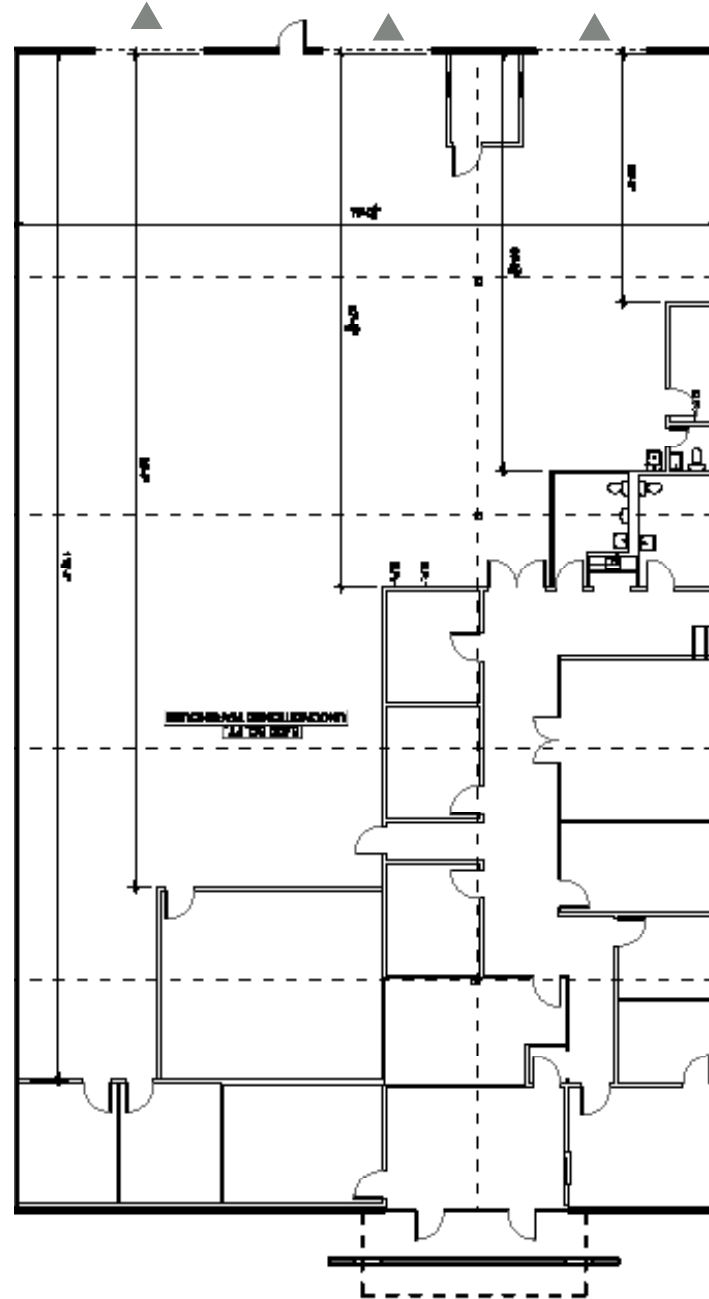

BLDG F

2538 - 2564

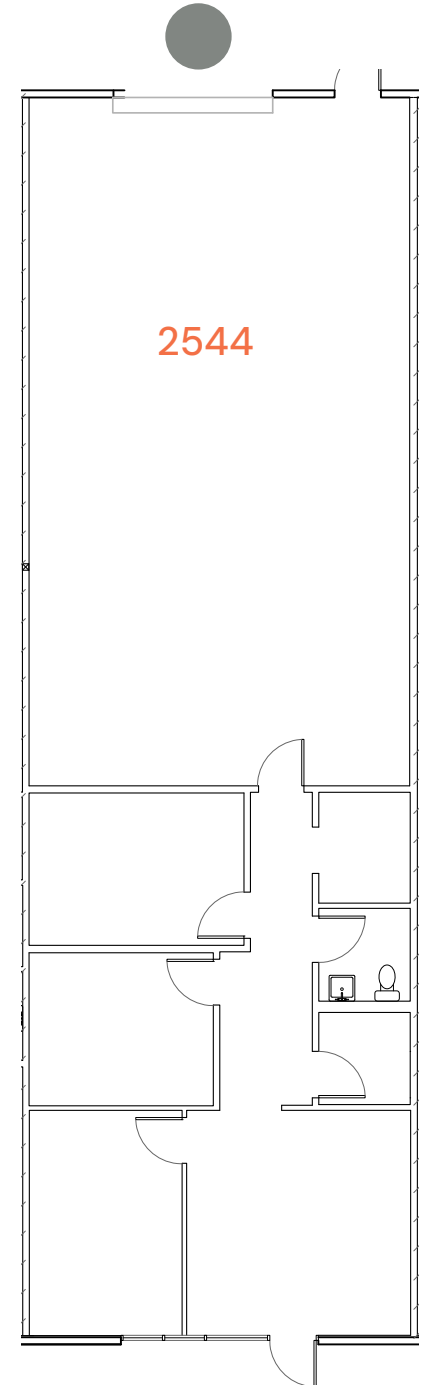
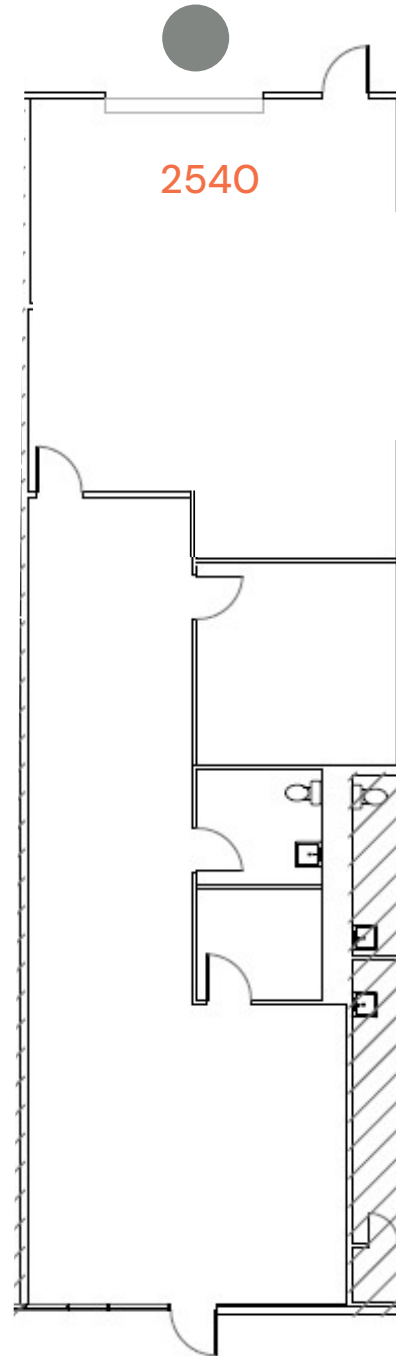

SUITE	F2540	F2544
SF	±1,903 SF	±2,039 SF
RATE	\$13.50 NNN	\$13.50 NNN
BUILD OUT	Office: 905 SF Warehouse: 1,134 SF	Office: 905 SF Warehouse: 1,134 SF
LOADING	1 Grade Level Door	1 Grade Level Door
COMMENTS	Available Now	Available Now

BLDG F

2538 - 2564

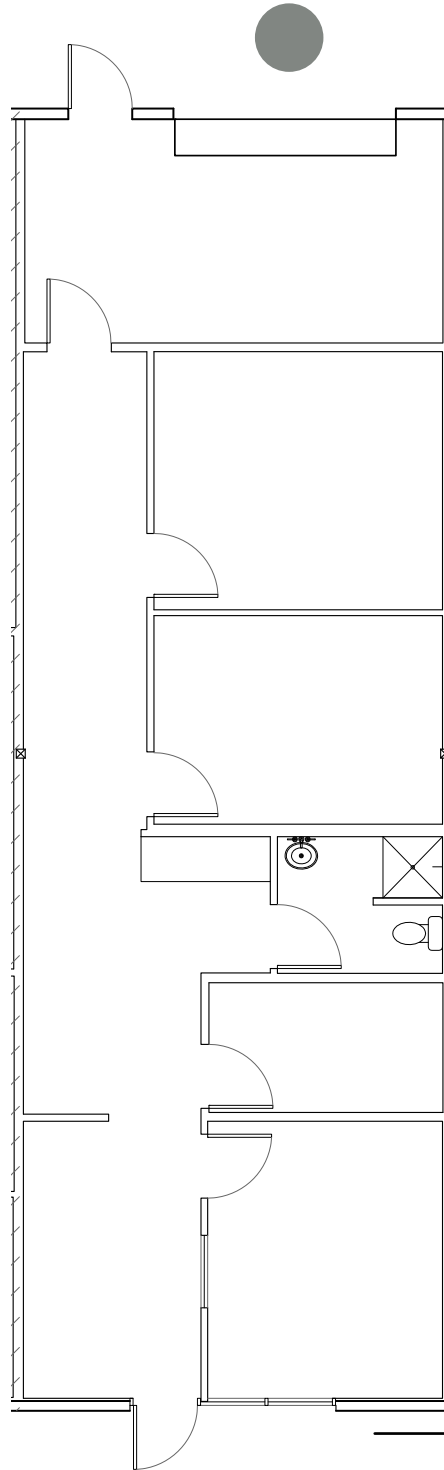

SUITE	F2558
SF	±1,232 SF
RATE	\$13.50 NNN
BUILD OUT	Office: 226 SF Warehouse: 1,006 SF
LOADING	1 Grade Level Door
COMMENTS	Available Now

BROADWAY TRADE CENTER

9929 BROADWAY STREET | SAN ANTONIO, TX 78217

FOR LEASE



For More
Information
Contact

Justin Roberts

Vice President

+1 210 841 3228

justin.roberts@cbre.com

Brad O'Neill

Vice President

+1 210 253 6070

brad.oneill@cbre.com



CBRE

© 2026 CBRE, Inc. All rights reserved. This information has been obtained from sources believed reliable but has not been verified for accuracy or completeness. CBRE, Inc. makes no guarantee, representation or warranty and accepts no responsibility or liability as to the accuracy, completeness, or reliability of the information contained herein. You should conduct a careful, independent investigation of the property and verify all information. Any reliance on this information is solely at your own risk. CBRE and the CBRE logo are service marks of CBRE, Inc. All other marks displayed on this document are the property of their respective owners, and the use of such marks does not imply any affiliation with or endorsement of CBRE. Photos herein are the property of their respective owners. Use of these images without the express written consent of the owner is prohibited.