

AVAILABLE FOR SALE

17 BUILDING, 2-STORY 169,278 SF INDUSTRIAL CAMPUS

246 E. 4th Street | Ashland, Ohio



HIGHLIGHTS

 **AVAILABLE SPACE**
169,278 SF TOTAL

 **DOCKS/GARAGE DOORS**
8 PLUS GARAGE DOORS

 **CLEARANCE HEIGHT**
18 FEET

 **CLOSE PROXIMITY**
TO I-71



Terry Coyne
Vice Chairman
216.218.0259
Terry.Coyne@nrmk.com
Licensed Real Estate Broker



Claire Coyne
Director
216.453.3015
Claire.Coyne@nrmk.com
Licensed Real Estate Salesperson



OFFICE BUILDING HIGHLIGHTS

- Built in 1930
- 10,000 SF, 2 floors
- Walls non-bearing
- Original brick
- Connects to manufacturing floor
- Safe included
- New roof in 2022
- Freight elevator

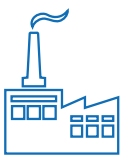

FACILITY HIGHLIGHTS

- 16 interconnected warehouse and factory buildings
- Mega power, 480 amps; substation
- Freight elevators
- Fully sprinklered
- Conveyor belts connect buildings across the street
- Parking: 2 surface lots for 100+ vehicle parking



LOCATION HIGHLIGHTS

- Rail spur access on site
- Approximately one hour from Cleveland
- Approximately one hour from Columbus
- 10 minutes to I-71

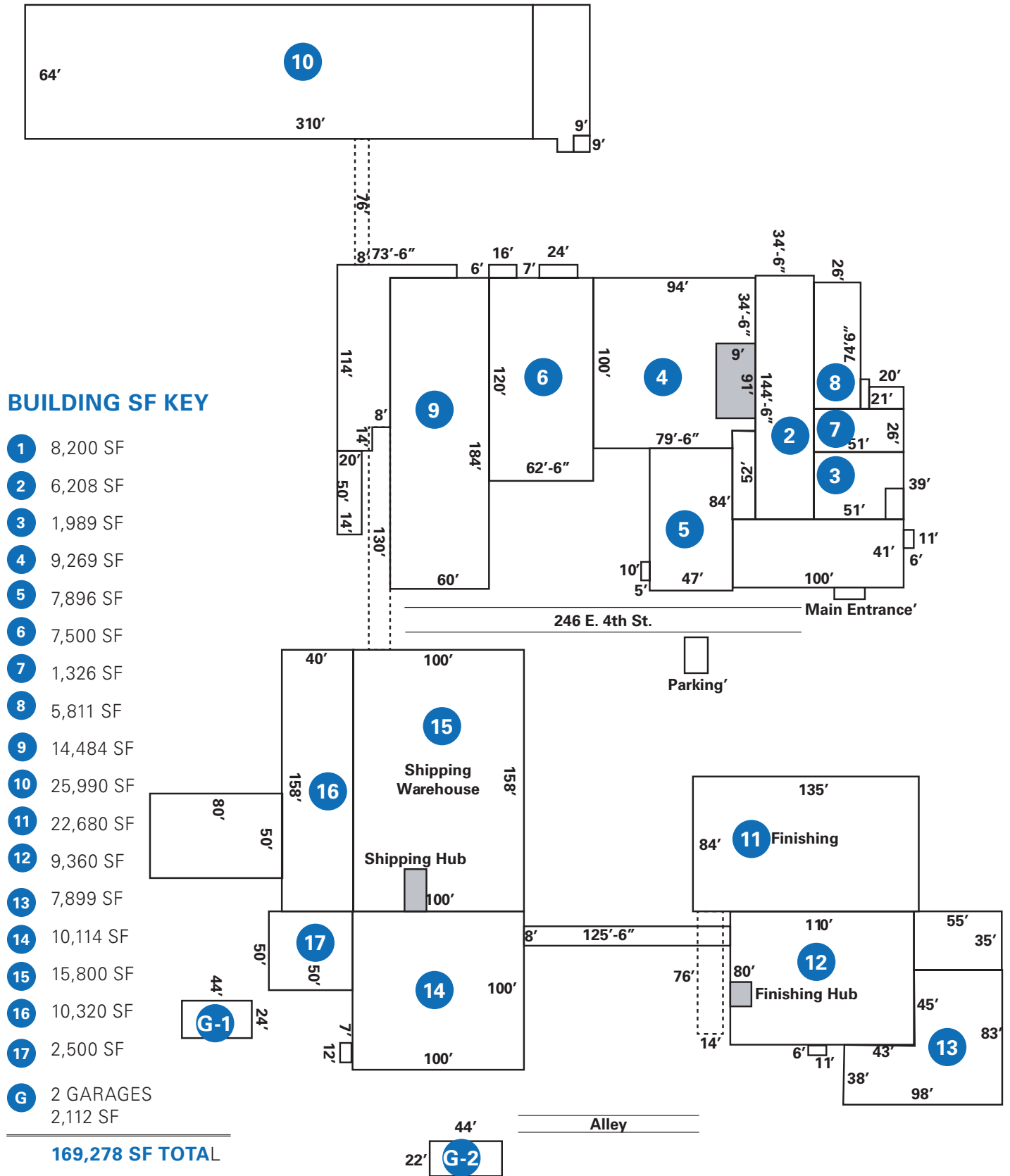

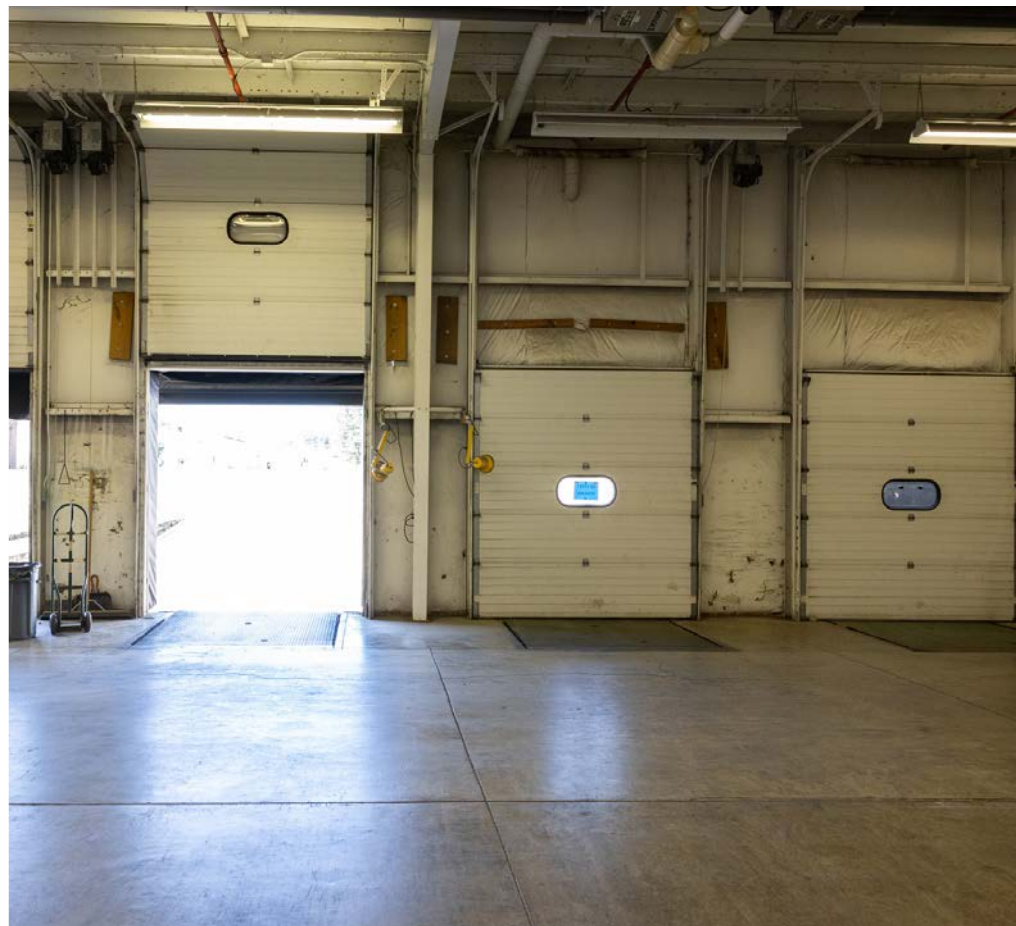



246 E. 4th Street | Ashland, Ohio

Connector Building Photos



246 E. 4th Street | Ashland, Ohio

















Exterior Office Building Photos









KEY FACTS	EDUCATION	INCOME	EMPLOYMENT	
 122,197 Population	 36.8% High School Diploma	 \$52,664 Median Household Income	 49.3% White Collar	 17.0% Services
 41.0 Median Age	 26.6% Some College	 \$27,995 Per Capita Income	 33.7% Blue Collar	 4.6% Unemployment Rate
 47,560 Households	 17.8% Bachelors/ Graduate/ Professional Degree	COMMUTERS	BUSINESS	
 \$44,764 Median Disposable Income		 12.3% Spend 7+ hours commuting to and from work per week	 32,594 Total Businesses	 512,259 Total Employees



LOCATION	DRIVE TIME	DRIVING DISTANCE
Akron, Ohio	48 minutes	48 miles
Cleveland, Ohio	1 hour and 3 minutes	65 miles
Columbus, Ohio	1 hour and 16 minutes	80 miles
Toledo, Ohio	1 hour and 45 minutes	99 miles
Pittsburgh, Pennsylvania	2 hours and 33 minutes	156 miles
Detroit, Michigan	2 hours and 34 minutes	153 miles
Cincinnati, Ohio	2 hours and 51 minutes	187 miles
Indianapolis, Indiana	3 hours and 49 minutes	253 miles
Buffalo, New York	3 hours and 57 minutes	250 miles
Chicago, Illinois	5 hours and 18 minutes	330 miles
Toronto, Canada	5 hours and 41 minutes	351 miles

