



LAKEWOOD

PROFESSIONAL VILLAGE

5920 100th Street SW, Units 18-25, Lakewood, WA

LAKEWOOD OWNER-USER OFFICE BUILDING FOR SALE

 **LEE &
ASSOCIATES**
COMMERCIAL REAL ESTATE SERVICES

All information furnished regarding property for sale, rental or financing is from sources deemed reliable, but no warranty or representation is made to the accuracy thereof and same is submitted to errors, omissions, change of price, rental or other conditions prior to sale, lease or financing or withdrawal without notice. No liability of any kind is to be imposed on the broker herein.

TABLE OF CONTENTS

PREPARED BY:

JOHN BAUDER

Principal

D 253.238.0043

jbauder@lee-associates.com

HARRISON LAIRD

Principal

D 253.238.0044

hlaird@lee-associates.com

PROPERTY OVERVIEW	3
Executive Summary	4
Property Aerial	5
Property Photos	6
Rent Roll	8
FLOOR PLANS	16
Upstairs Floor Plan	17
Main Floor Plan	18
Downstairs Floor Plan	19
Basement Floor Plan	20

DISCLAIMER

We obtained the information above from sources we believe to be reliable. However, we have not verified its accuracy and make no guarantee, warranty or representation about it. It is submitted subject to the possibility of errors, omissions, change of price, rental or other conditions, prior sale, lease or financing, or withdrawal without notice. We include projections, opinions, assumptions or estimates for example only, and they may not represent current or future performance of the property. You and your tax and legal advisors should conduct your own investigation of the property and transaction.

DISCLAIMER STATEMENT

Lee & Associates (the "Agent") has been engaged as the exclusive sales representative for the sale of the Lakewood Professional Center, Units 18-25 (the "Property") by 'Ownership' (the "Seller").

This Memorandum does not constitute a representation that the business or affairs of the Property or Seller since the date of preparation (April 2024) of this Memorandum have remained the same. Analysis and verification of the information contained in this Memorandum are solely the responsibility of the prospective purchaser.

Additional information and an opportunity to inspect the Property will be made available upon written request of interested and qualified prospective purchasers. Seller and Agent each expressly reserve the right, at their sole discretion, to reject any or all expressions of interest or offers regarding the Property, and/or terminate discussions with any party at any time with or without notice. Seller reserves the right to change the timing and procedures for the Offering process at any time in Seller's sole discretion. Seller shall have no legal commitment or obligations to any party reviewing this Memorandum, or making an offer to purchase the Property, unless and until such offer is approved by Seller, and a written agreement for the purchase of the Property has been fully executed and delivered by Seller and the Purchaser thereunder.

This Memorandum and the contents, except such information which is a matter of public record or is provided in sources available to the public, are of a confidential nature. By accepting this Memorandum, you agree that you will hold and treat it in the strictest confidence, that you will not forward, photocopy or duplicate it, that you will not disclose this Memorandum or any of the contents to any other entity (except to outside advisors retained by you, if necessary, for your determination of whether or not to make a proposal and from whom you have obtained an agreement of confidentiality) without the prior written authorization of Seller or Agent, and that you will not use this Memorandum or any of the contents in any fashion or manner detrimental to the interest of Seller or Agent.



PROPERTY OVERVIEW

EXECUTIVE SUMMARY

PROPERTY AERIAL

PROPERTY PHOTOS

RENT ROLL

EXECUTIVE SUMMARY

Ideal owner-user opportunity in the heart of Lakewood with a mix of existing retail and office users, all on month-to-month leases. An owner-user could occupy 446-7,428 square feet; Beyler Consulting is also willing to downsize and renew its lease in the building. Building layout and existing buildout make suite-sizes flexible, allowing an owner-user to occupy their desired portion of the building and easily lease the balance.

The building was updated in 2017 including roof, HVAC, finishes, and bathrooms.

HOA fees are approximately \$535/month for 2024; HOA fees cover garbage, evening security, and common area maintenance including parking lots, landscaping, and lighting.



BUILDING SIZE:	7,428 SF
LAND SIZE:	15,868 SF
YEAR BUILT:	1964
YEAR UPDATED:	2017
ZONING:	Lakewood CBD
TAX PARCELS:	5135000030 5135000011
SALE PRICE:	\$1,495,000

PROPERTY AERIAL



PROPERTY PHOTOS



RENT ROLL

UNIT	SIZE (SF)	TENANT NAME	MONTHLY RENT	GROSS LEASE RATE	LEASE EXPIRATION
24 & 25	3,322	Beyler Consulting	\$4,200	\$15.17	M2M
23	744	ACME Physicians Group	\$550	\$8.87	M2M
22	654	Lakewood Massage	\$850	\$15.60	M2M
20	486	A&B Homecare	\$550	\$13.58	M2M
19	446	Jason Davies	\$782.25	\$21	9/30/2025
18	684	Vacant	-	-	
Basement	1,082	Vacant	-	-	





FLOOR PLANS

UPSTAIRS FLOOR PLAN

MAIN FLOOR PLAN

DOWNSTAIRS FLOOR PLAN

BASEMENT

FLOOR PLANS

UPSTAIRS

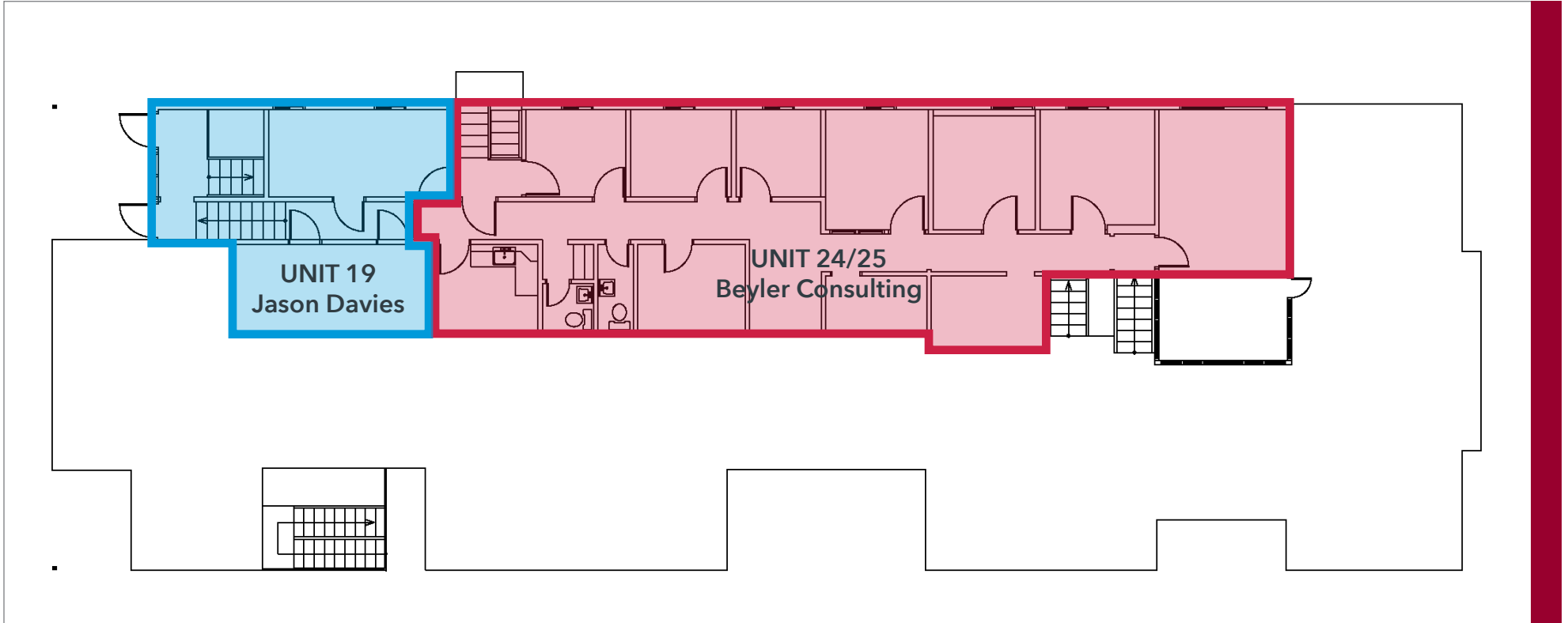

FLOOR PLANS

MAIN

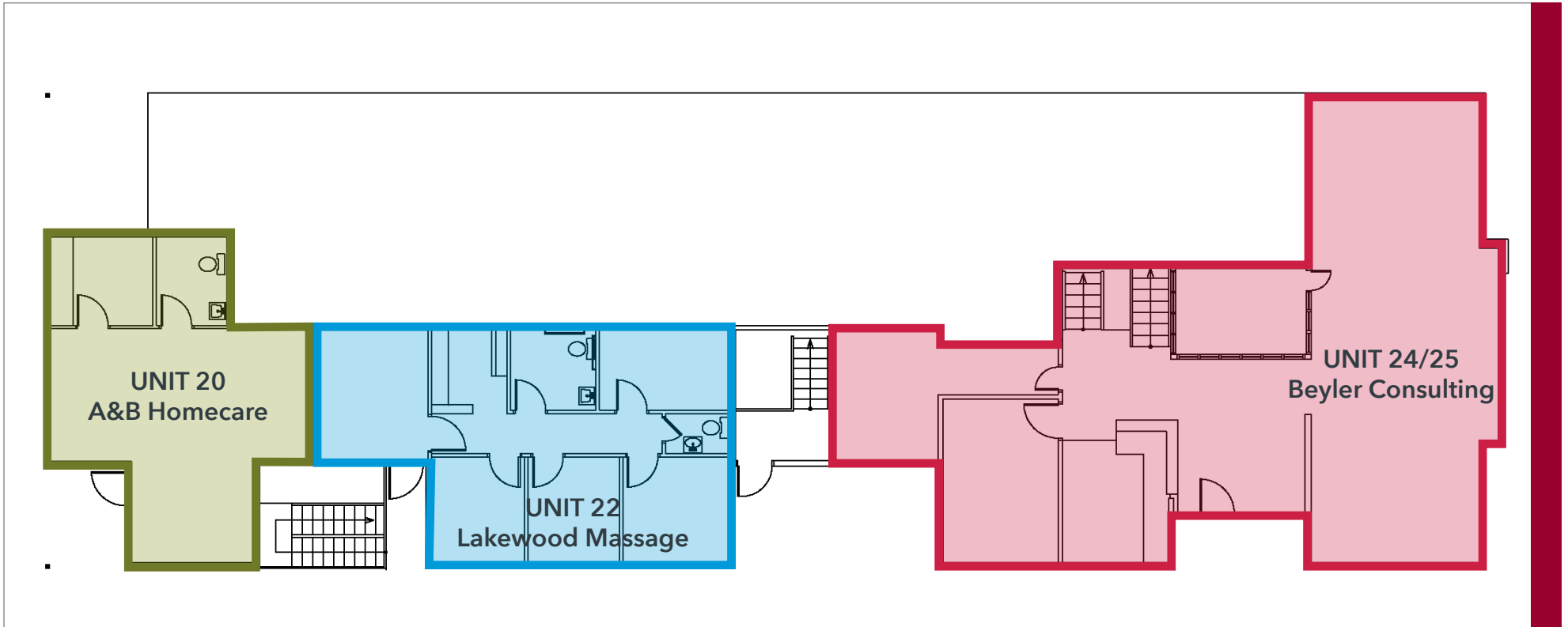

FLOOR PLANS

DOWNSTAIRS

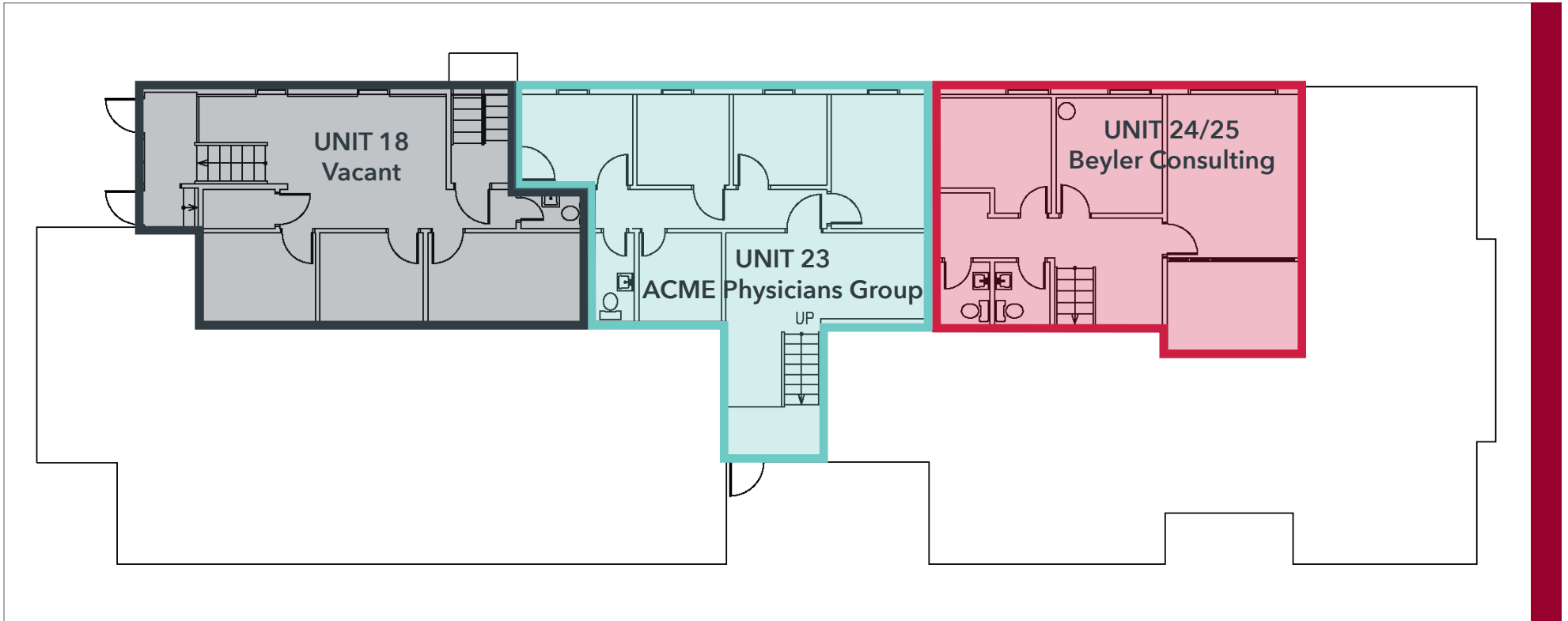

FLOOR PLANS

BASEMENT

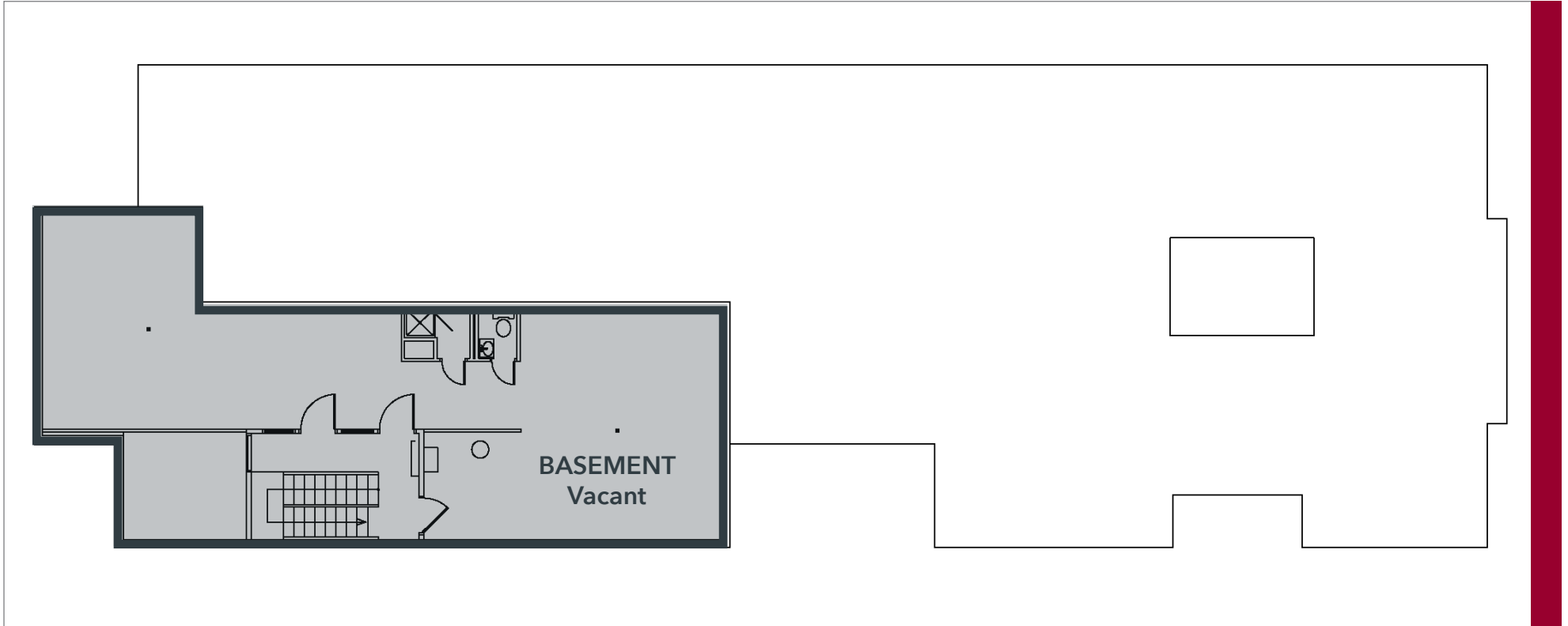

JOHN BAUDER

Principal

D 253.238.0043

jbauder@lee-associates.com

HARRISON LAIRD

Principal

D 253.238.0044

hlaird@lee-associates.com

950 Pacific Avenue, Suite 200, Tacoma, WA 98402

O 253.383.8382 | lee-nw.com

DISCLAIMER

We obtained the information above from sources we believe to be reliable. However, we have not verified its accuracy and make no guarantee, warranty or representation about it. It is submitted subject to the possibility of errors, omissions, change of price, rental or other conditions, prior sale, lease or financing, or withdrawal without notice. We include projections, opinions, assumptions or estimates for example only, and they may not represent current or future performance of the property. You and your tax and legal advisors should conduct your own investigation of the property and transaction.

Broker Marketing\5920 100th St SW, Lakewood\Sale 2024\OMs\5920 100th St SW OM 04.2024

