



For Lease

Industrial Space

Ideal for warehousing, distribution and light industrial

**650 Godin Avenue,
Quebec City | QC**

Featured Benefits

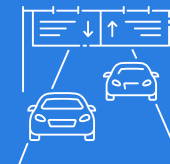

**Excellent
accessibility**



Ample parking



**Located in the
heart of Quebec**



Property Overview

Civic Address 650 Godin Avenue, Quebec City, QC

Zoning Industrial

Zoning information

- C1 Administrative services
- C2 Retail Sales and Services
- C36 Repair shop
- C37 Auto Body Shop
- C40 Warehouse generator
- I2 Craft industry
- I3 General Industry

Suite #175

Total Area 8,309 SF

Shipping 1TL | 1DI

Clear Height ±17'

Availability Immediately

OPEX \$4.92/ SF

Suite #199

Total Area 2,472 SF

Shipping 1TL

Clear Height ±17'

Availability Immediately

OPEX \$6.16/ SF



**Asking Rental Rate:
Contact Broker**

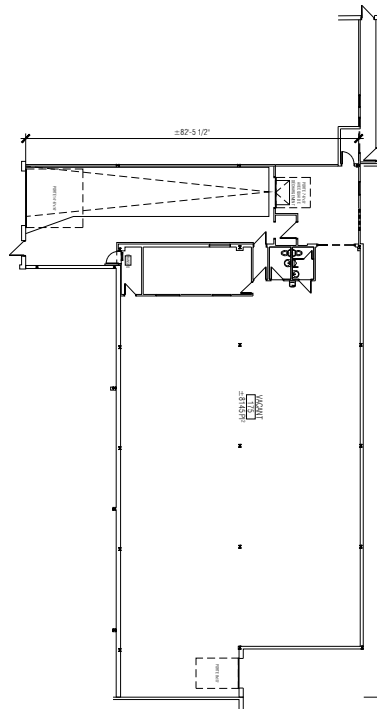
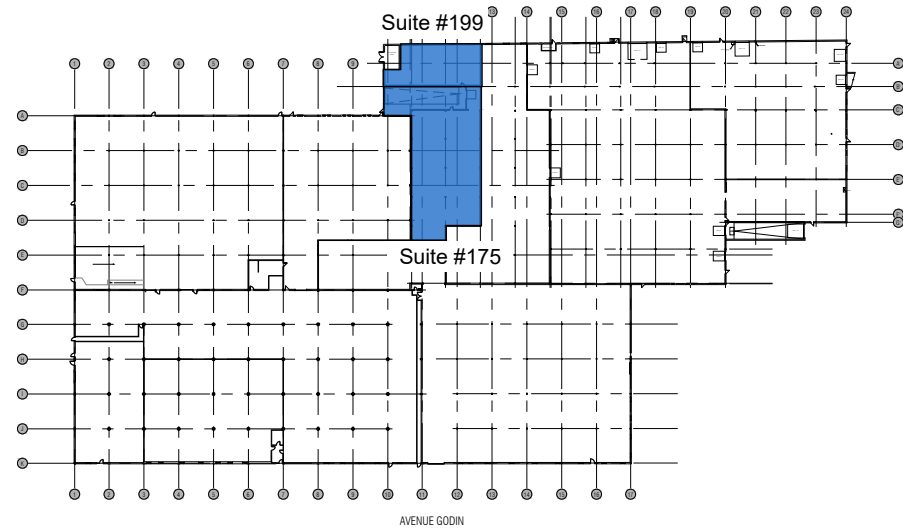

Suite #175

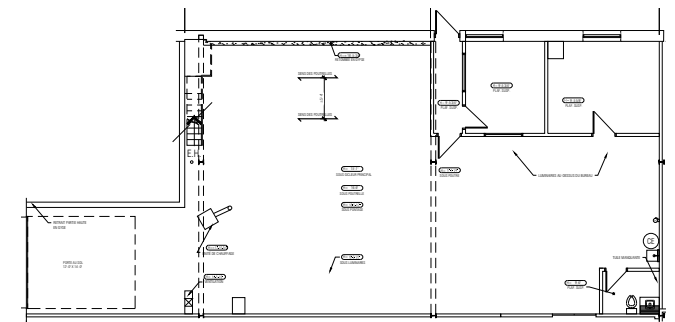

Suite #199



Nearby Amenities

 650 Godin Avenue,
Quebec City, QC

- 1 Oeuforie / Steak Frites
- 2 A&W
- 3 Harvey's
- 4 Metro Plus
- 5 Usine Laura Secord
- 6 Carrefour Soumande
- 7 Les Halles Fleur de Lys
- 8 Sport Évolution le Gym
- 9 Les Galeries de la Capitale

 **Highway 40 (Trans-Canada)**
1.5 km | 4 minutes

 **Highway 740**
3.5 km | 7 minutes

 **Pierre-Bertand Boulevard**
0.5 km | 2 minutes

 **Gare du Palais (Intermodal)**
7 km | 15 minutes

 **Sainte-Foy Station**
11.5 km | 30 minutes

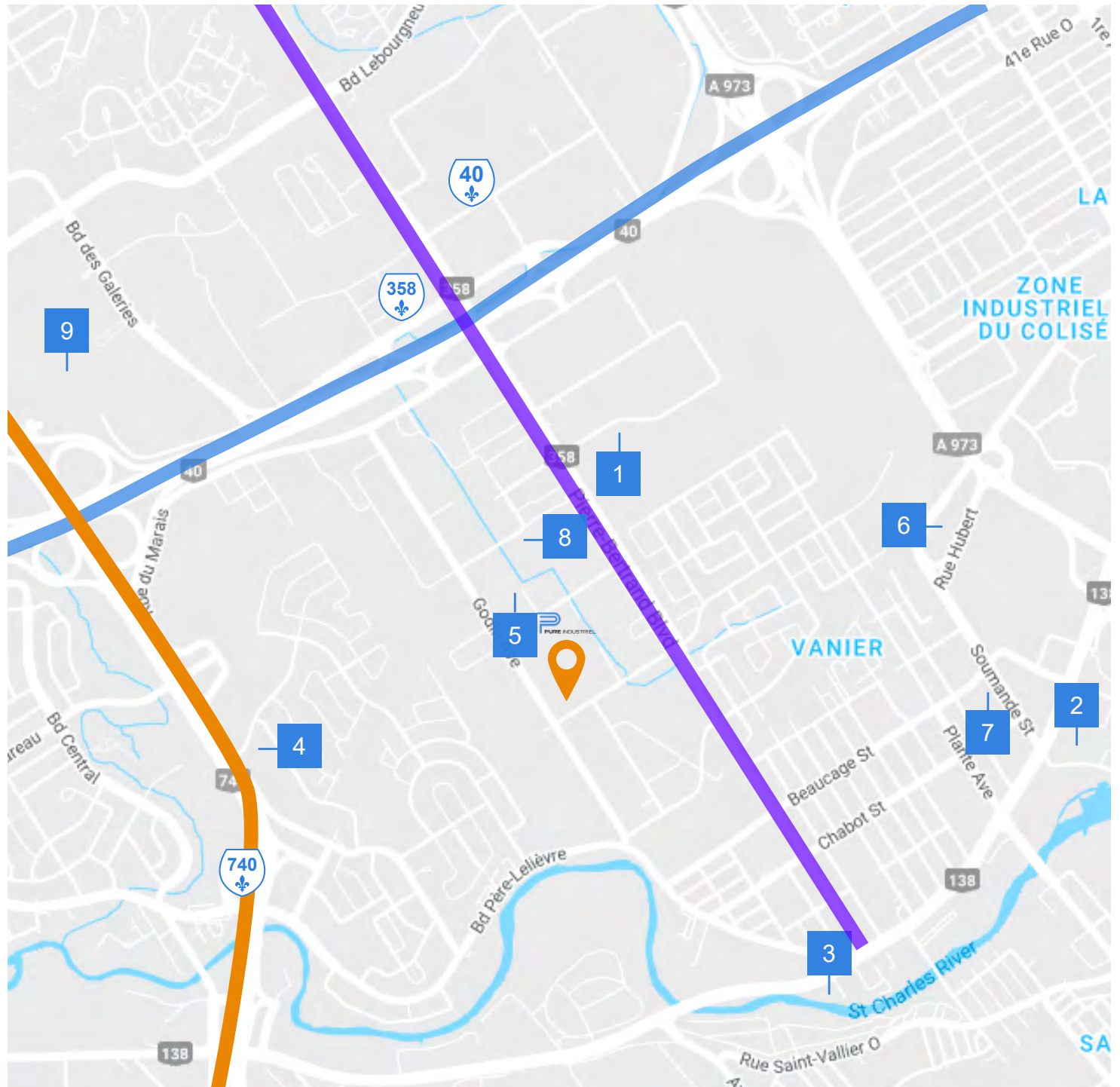

Our Team



Pure Industrial is one of Canada's leading providers of industrial real estate.

Headquartered in Toronto, with offices in Montreal, Quebec City, and Vancouver, Pure Industrial owns and operates a portfolio of over 40 million square feet of high-quality and well-located assets, ranging from small warehouses to large industrial developments.

Our strategic focus has enabled us to develop and refine our unique industrial real estate offering in order to serve the needs of customers, with premium industrial real estate in locations that are critical for the Canadian supply chain, from the first mile, to the last.

Pure prides itself on its professional and customer service-oriented team, building long-term relationships with tenants based on providing highly-responsive, personalized service.

pureindustrial.ca



Colliers

Colliers is a leading diversified professional services and investment management company. With operations in 65 countries, our more than 15,000 enterprising professionals work collaboratively to provide expert advice to real estate occupiers, owners, and investors.

With annualized revenues of \$3.6 billion (\$4.0 billion including affiliates) and \$46 billion of assets under management, we maximize the potential of property and accelerate the success of our clients and our people.

collierscanada.com



650 Godin Avenue, Quebec City, QC

Maxime Paquet

Senior Associate
Commercial Real Estate Broker
+1 418-473-9974
maxime.paquet@colliers.com

Patrick Soucy

Senior Vice President
Chartered Real Estate Broker
+1 418 648 0911
patrick.soucy@colliers.com

William Grenon

Senior Associate
Commercial Real Estate Broker
+1 418 648 0911
william.grenon@colliers.com



This document has been prepared by Colliers International for advertising and general information only. This document is not an offer or promise to purchase, but is an invitation to submit an offer or promise to purchase. Colliers International makes no guarantees, representations or warranties of any kind, expressed or implied, regarding the information including, but not limited to, warranties of content, accuracy and reliability. Any interested party should undertake their own inquiries as to the accuracy of the information. Colliers International excludes unequivocally all inferred or implied terms, conditions and warranties arising out of this document and excludes all liability for loss and damages arising there from. This publication is the copyrighted property of Colliers International and/or its licensor(s). © 2022. All rights reserved. This communication is not intended to cause or induce breach of an existing listing agreement. Colliers International (Québec) Inc. Real Estate Agency.