

# 939 BURKE STREET - WINSTON-SALEM, NC

OFFICE SPACES FOR LEASE



**939 BURKE STREET**  
WINSTON-SALEM, NC 27101

## PROPERTY DESCRIPTION

Prime office leasing availability in sought-after Burke House. This multi-tenant property is in the center of the charming West End District, surrounded by various retail, office, and residential. Key features include secure location in well-trafficked corridor, ample surface parking, synergetic blend of tenants, and ease of access to highway and suburban Winston-Salem.

## OFFERING SUMMARY

|               |  |
|---------------|--|
| Available SF: | ±325 and ±1,109 SF                             |
| Lease Rate:   | Suite C: \$1,350/Month<br>Suite E: \$625/Month |
| Lease Type:   | Modified Gross                                 |

Aubrey Linville

336.345.7300  
aubrey@ltpcommercial.com

Cali Rich

857.204.8326  
cali@ltpcommercial.com

**Linville | Team Partners**  
COMMERCIAL REAL ESTATE

WINSTON-SALEM, NC

L | T

# 939 BURKE STREET - WINSTON-SALEM, NC

OFFICE SPACES FOR LEASE



Aubrey Linville

336.345.7300  
aubrey@ltpcommercial.com

Cali Rich

857.204.8326  
cali@ltpcommercial.com

Linville | Team Partners  
COMMERCIAL REAL ESTATE

# 939 BURKE STREET - WINSTON-SALEM, NC

OFFICE SPACES FOR LEASE



Aubrey Linville

336.345.7300  
aubrey@ltpcommercial.com

Cali Rich

857.204.8326  
cali@ltpcommercial.com

Linville | Team Partners  
COMMERCIAL REAL ESTATE

# 939 BURKE STREET - WINSTON-SALEM, NC

OFFICE SPACES FOR LEASE

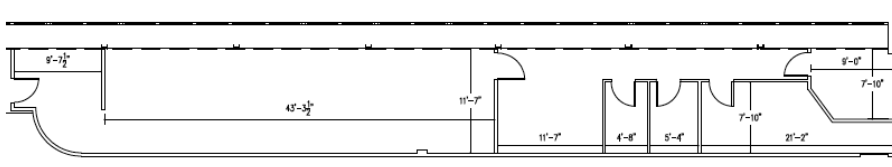

939 Burke Street

Suite C  
1,109 SF

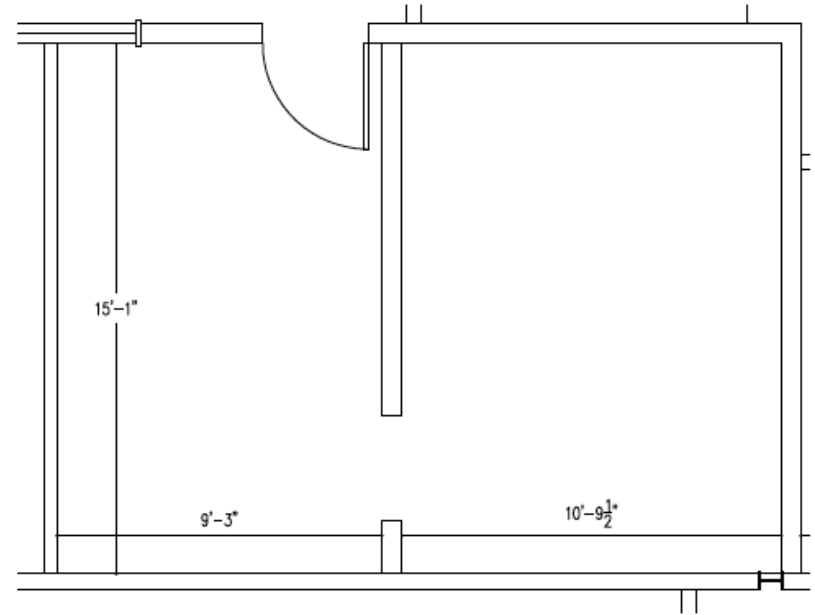

939 Burke Street

Suite E  
325 SF

Aubrey Linville

336.345.7300  
aubrey@ltpcommercial.com

Cali Rich

857.204.8326  
cali@ltpcommercial.com

Linville | Team Partners  
COMMERCIAL REAL ESTATE

## 939 BURKE STREET - WINSTON-SALEM, NC

OFFICE SPACES FOR LEASE

## LOCATION INFORMATION

|                  |                         |
|------------------|-------------------------|
| Street Address   | 939 Burke Street        |
| City, State, Zip | Winston-Salem, NC 27101 |

## PROPERTY INFORMATION

|               |              |
|---------------|--------------|
| Property Type | Retail       |
| Tax Pin       | 6825-86-7054 |
| Zoning        | PB           |
| Lot Size      | 0.53 Acres   |
| Building Size | ±19,333 SF   |
| Suite C       | ±1,109 SF    |
| Suite E       | ±325 SF      |
| Year Built    | 1941         |
| Parking       | Surface Lot  |



**LEASE RATE: \$1,350/MONTH  
AND \$625/MONTH (MG)**

Aubrey Linville

336.345.7300  
aubrey@ltpcommercial.com

Cali Rich

857.204.8326  
cali@ltpcommercial.com

Linville | Team Partners

COMMERCIAL REAL ESTATE

The information contained herein has been taken from sources deemed to be reliable. Linville Team Partners makes no representation or warranties, expressed or implied, as to the accuracy of this information. All information in this document is subject to verification prior to purchase or lease.