

## LOCATION

535 N Broad St, Canfield, OH 44406

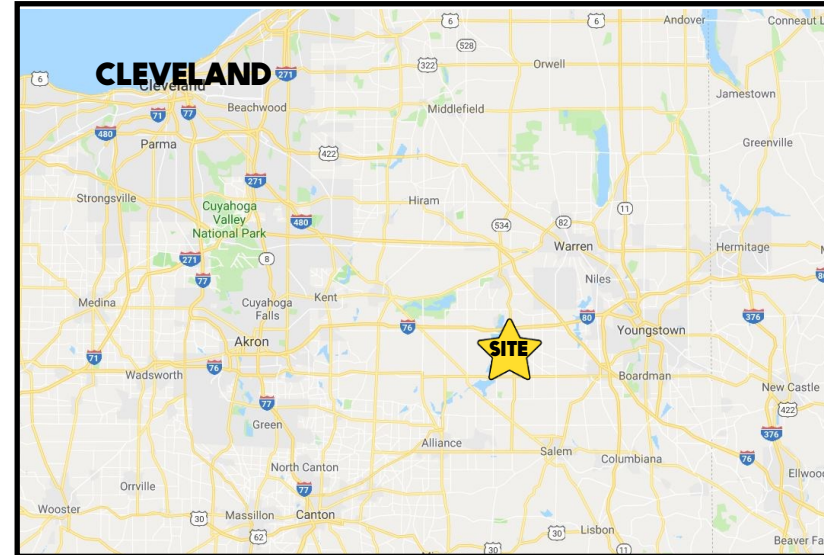

## HIGHLIGHTS

- Executive office in prestigious Canfield, OH
- Multiple offices with conference room and kitchenette
- Reception / waiting area
- Plenty of parking
- Located just south of Herbert Rd / 62

## TRAFFIC

Broad St (SR 46) = 8,647 VPD

## CONTACT

**MATT WILSON**

330.347.9677      mwilson@platzrealtygroup.com

**ADAM DIVELBISS**

501.551.3817      adivelbiss@platzrealtygroup.com

Office: 330.757.4889 | Fax: 330.294.5622 | 3830 Starr Centre Dr, Suite 2, Canfield, OH 44406

[www.PLATZREALTYGROUP.com](http://www.PLATZREALTYGROUP.com)



Office: 330.757.4889 | Fax: 330.294.5622 | 3830 Starr Centre Dr, Suite 2, Canfield, OH 44406

**[www.PLATZREALTYGROUP.com](http://www.PLATZREALTYGROUP.com)**

The information presented was obtained from sources believed to be true and reliable. The Platz Realty Group makes no warranties or guarantees to the accuracy of the information.

Unit 2

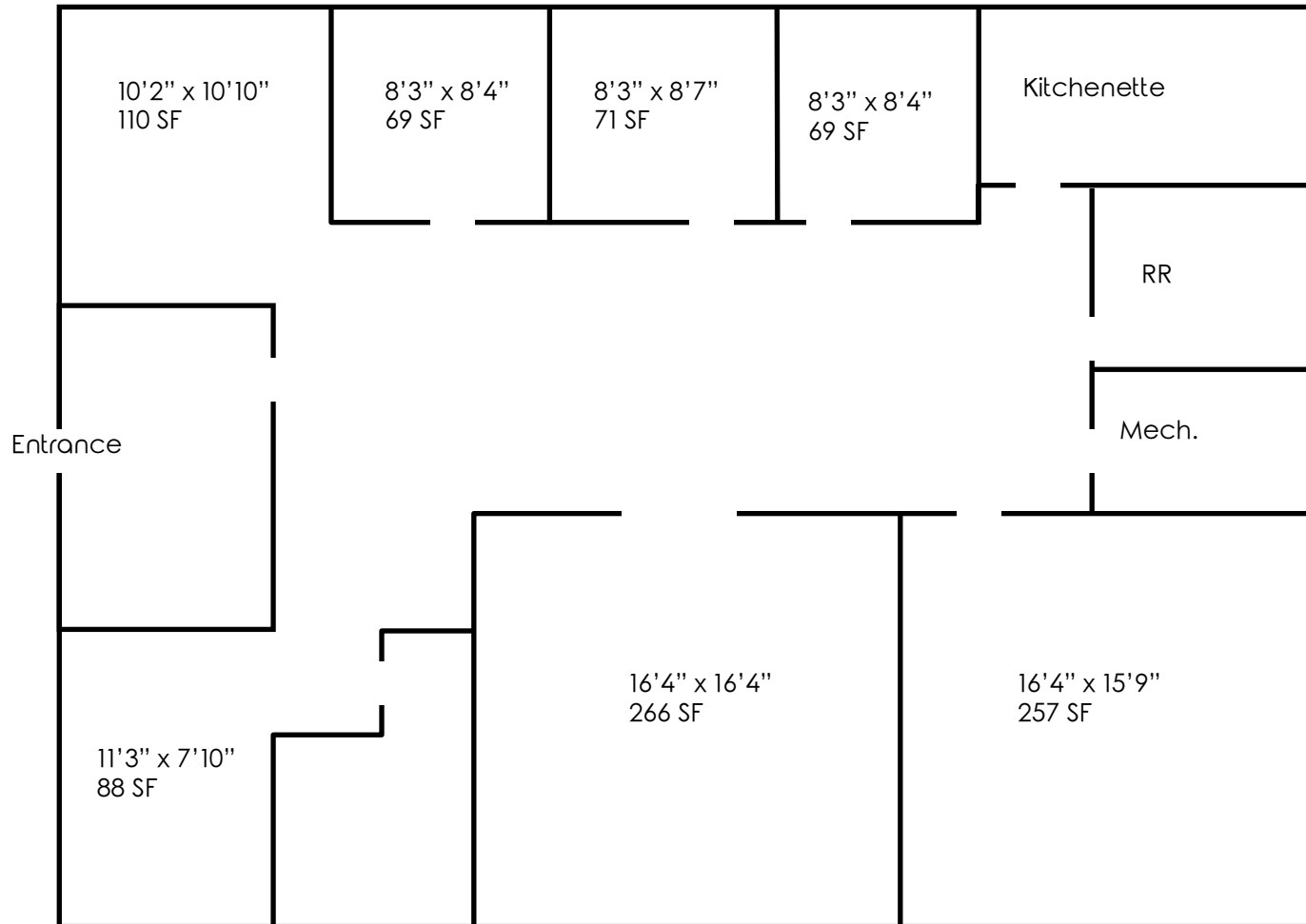

Office: 330.757.4889 | Fax: 330.294.5622 | 3830 Starr Centre Dr, Suite 2, Canfield, OH 44406

Unit 5

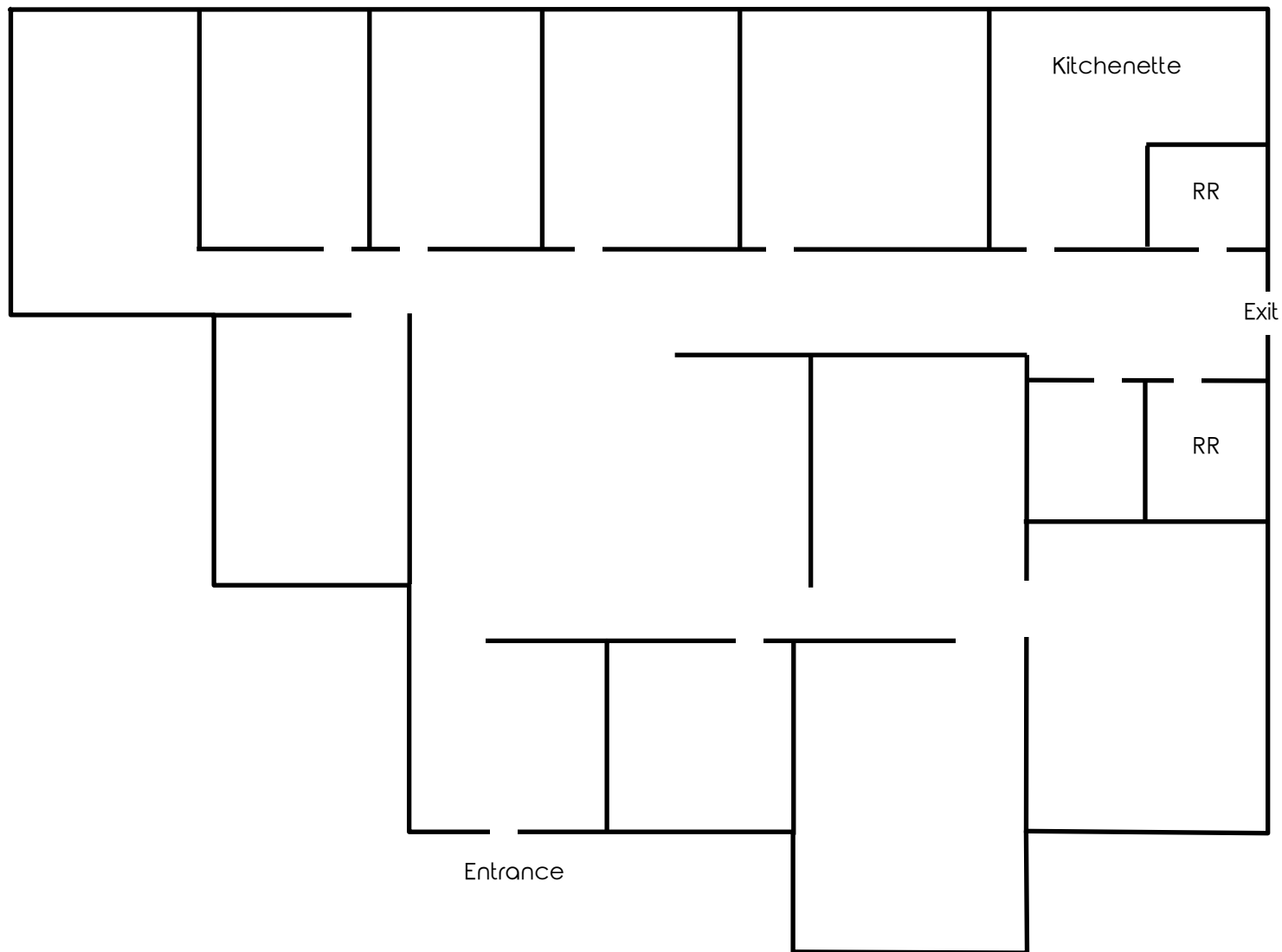

Office: 330.757.4889 | Fax: 330.294.5622 | 3830 Starr Centre Dr, Suite 2, Canfield, OH 44406

**[www.PLATZREALTYGROUP.com](http://www.PLATZREALTYGROUP.com)**

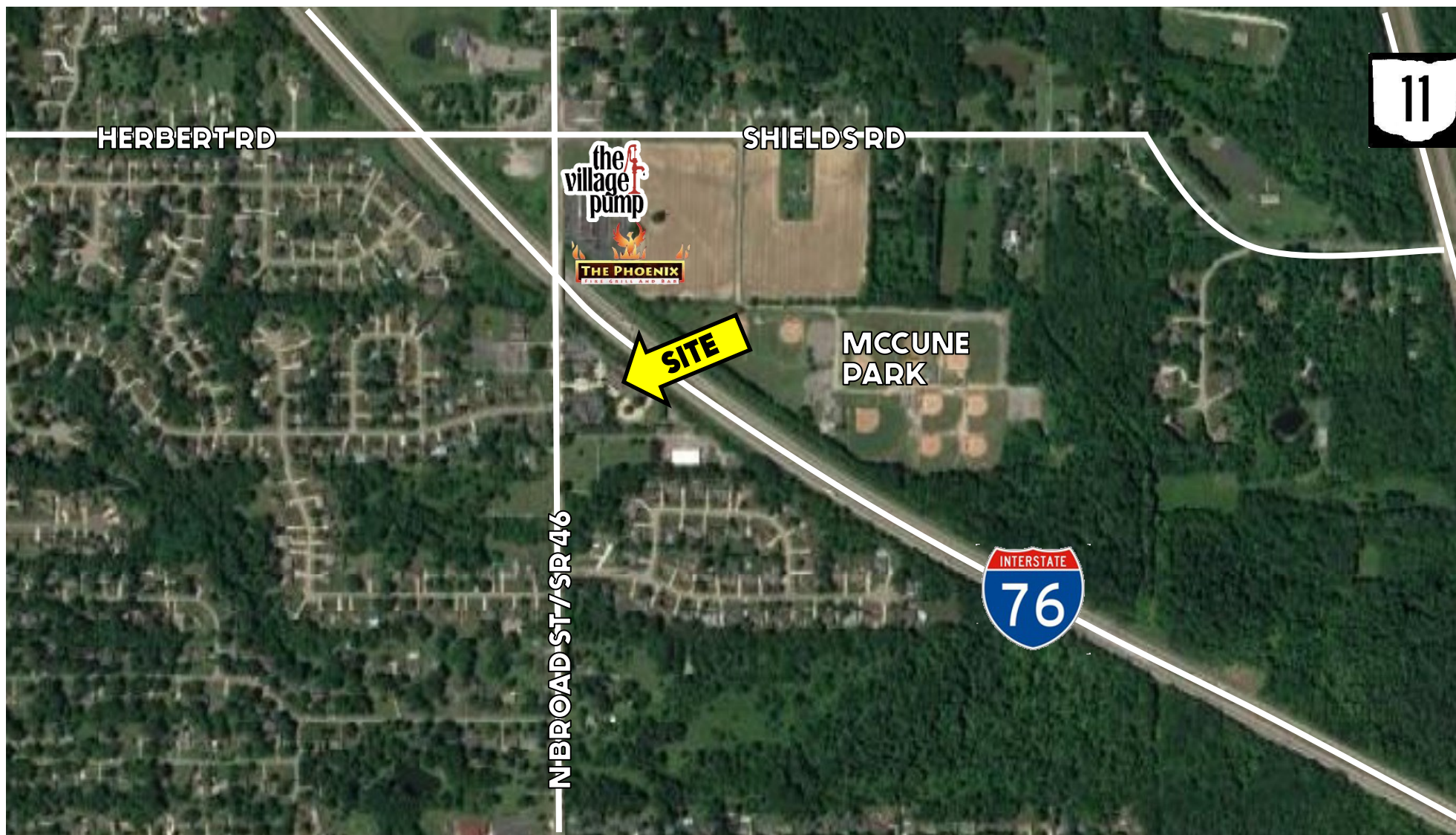

Office: 330.757.4889 | Fax: 330.294.5622 | 3768 Boardman Canfield Rd, Canfield, OH 44406

[www.PLATZREALTYGROUP.com](http://www.PLATZREALTYGROUP.com)

The information presented was obtained from sources believed to be true and reliable. The Platz Realty Group makes no warranties or guarantees to the accuracy of the information.

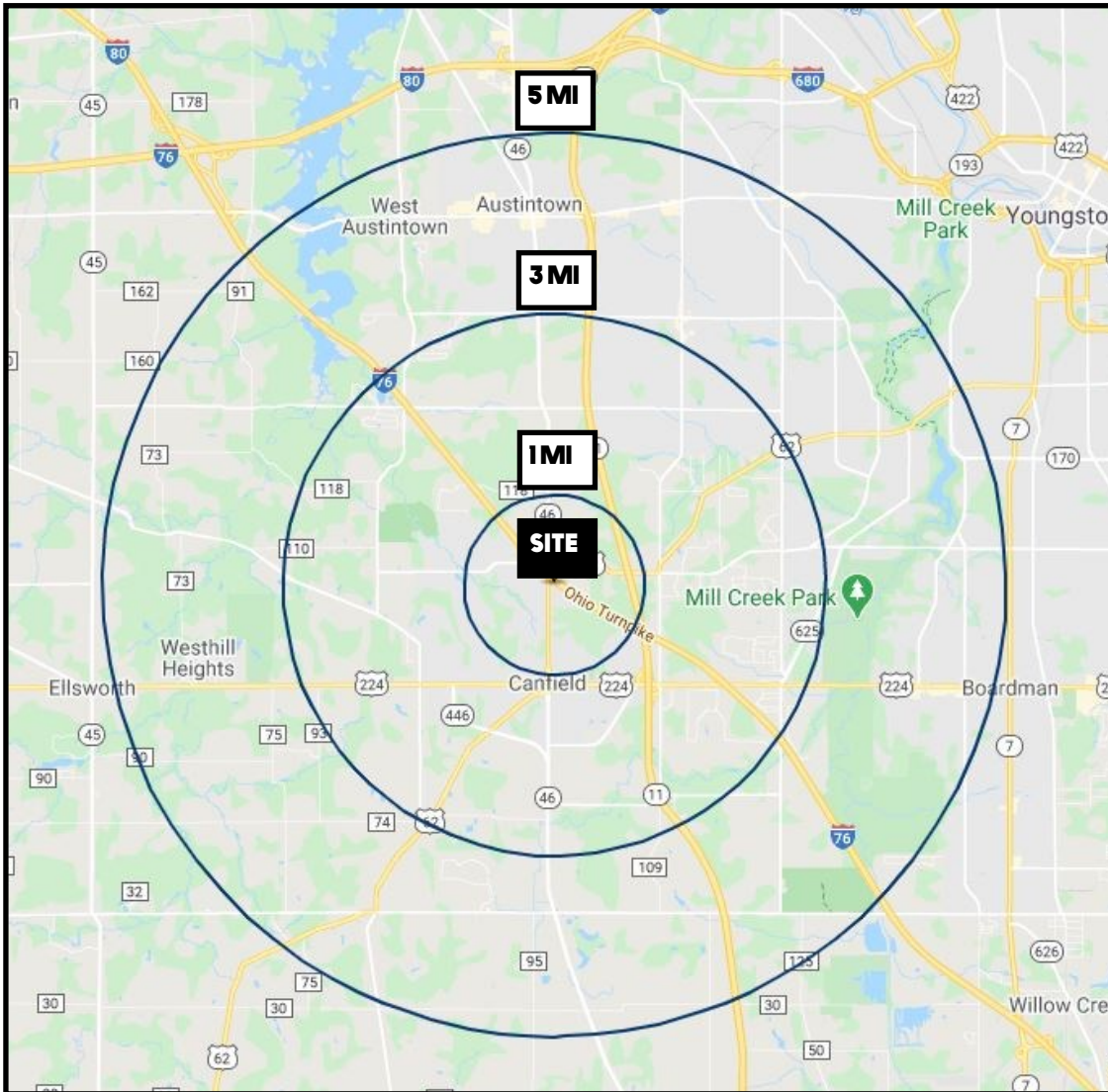

DEMOGRAPHICS	1 MI	3 MI	5 MI
<b>POPULATION</b>	3,607	26,942	77,331
<b>HOUSEHOLDS</b>	1,406	10,926	33,284
<b>MEDIAN AGE</b>	47	46	45
<b>AVERAGE HH INCOME</b>	\$106,816	\$95,105	\$74,405

**SITE INFORMATION**

<b>LOCATION</b>	Canfield City Mahoning County
<b>PROPERTY TYPE</b>	Office
<b>PARKING</b>	Ample on site parking
<b>YEAR BUILT</b>	1997
<b>AVAILABLE</b>	Unit 2: 1,700 SF Unit 5: 2,500 SF
<b>UTILITIES</b>	Gas and electric are separately metered
<b>GROSS RENT</b>	2: \$14.00/SF 5: \$13.00/SF

Office: 330.757.4889 | Fax: 330.294.5622 | 3830 Starr Centre Dr, Suite 2, Canfield, OH 44406