

# MEDICAL OFFICE SUITE AVAILABLE FOR LEASE



81 SPRINGSIDE DRIVE  
AKRON, OH 44333

LEASE RATE: \$5,000/MO + UTILITIES



## PROPERTY HIGHLIGHTS

- Approximately: 3,000 SF
- Price per SF: \$20.00/SF
- **Suite A** - Consists of 8 Private Offices, Waiting Area, Reception Area, Kitchenette, 2 Handicap Accessible Restroom, Washer/Dryer Room, and Storage
- The Suite is Move-in Ready, Clean, and has Great Functionality for a Medical User
- Tenant Pays Gas, Electric, Water, and Sewer
- Signage Available on Marquee Board
- Parking: 52± Spaces in the Front of the Building
- Close to I-77 Expressway with Exposure from West Market Street and Across from the New Sheetz Development



## LISTING AGENT

**Sam Tecca**

Sam@GerspacherGroup.com

**330.722.5002**



# MEDICAL OFFICE SUITE AVAILABLE FOR LEASE



81 SPRINGSIDE DRIVE  
AKRON, OH 44333

LEASE RATE: \$5,000/MO + UTILITIES



## PROPERTY OVERVIEW

81 Springside Drive is a 3,000 SF former Cryotherapy Plus & Luxury Spa space. Upon entering the suite there is a reception area which leads to a circular pathway of 8 private offices and a kitchenette. Other tenants within the plaza include Trained by Trav and Nails 90 & Spa. Please contact Sam Tecca for additional information and to set up a showing.

## LOCATION OVERVIEW

Close to I-77 expressway with exposure from West Market Street.

### DEMOGRAPHICS

	1 MILE	3 MILES	5 MILES
Total Households	1,767	12,063	25,539
Total Population	3,676	29,754	59,419
Average HH Income	\$165,782	\$164,080	\$137,571

*The information contained herein is from sources deemed reliable but no warranty or representation is made to the accuracy thereof.*



# MEDICAL OFFICE SUITE AVAILABLE FOR LEASE



81 SPRINGSIDE DRIVE  
AKRON, OH 44333

LEASE RATE: \$5,000/MO + UTILITIES

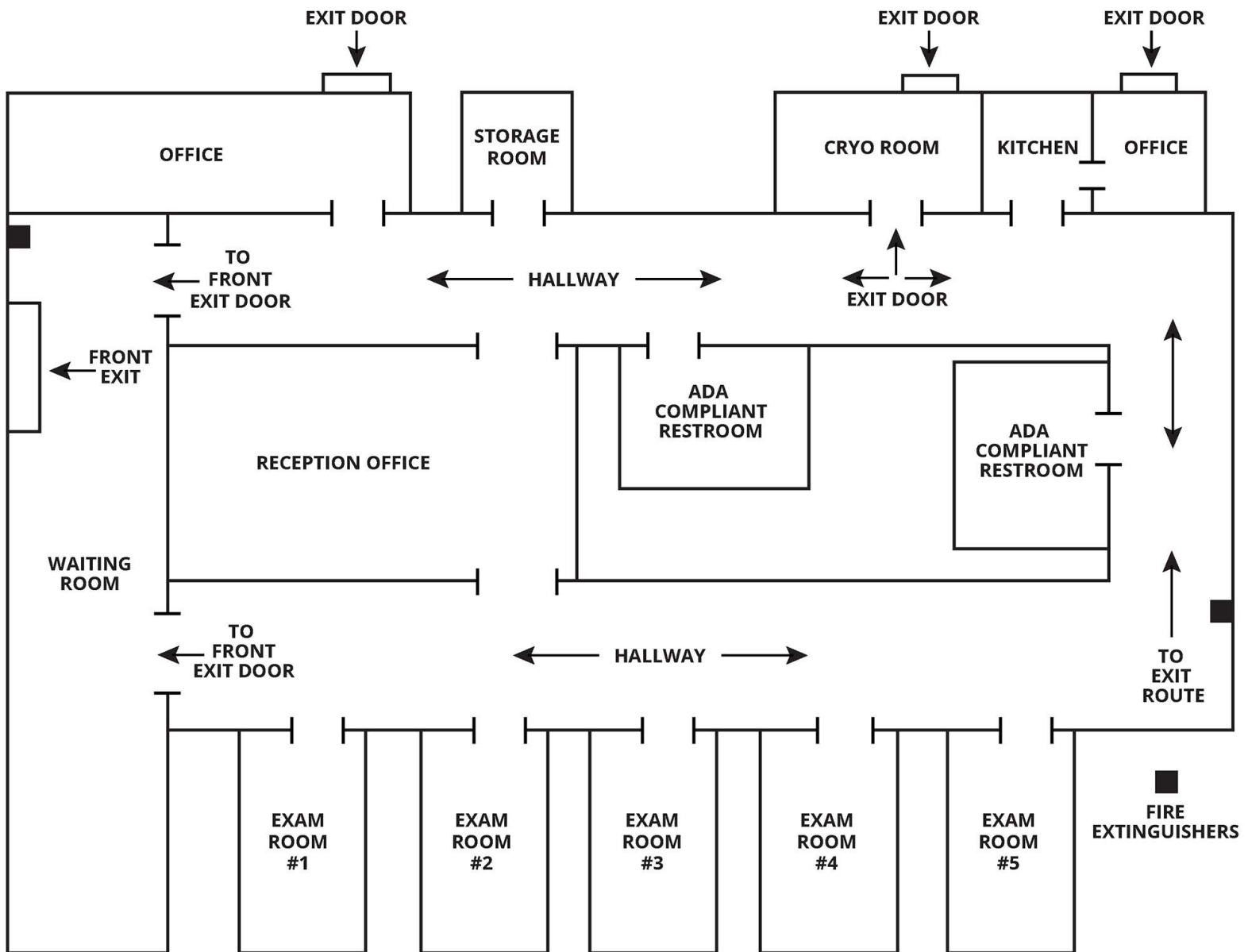

# MEDICAL OFFICE SUITE AVAILABLE FOR LEASE



81 SPRINGSIDE DRIVE  
AKRON, OH 44333

**LEASE RATE: \$5,000/MO + UTILITIES**

