

## Restaurant / Retail Storefront on Film Row (Sheridan Ave.) w/ Plumbing & Grease Trap

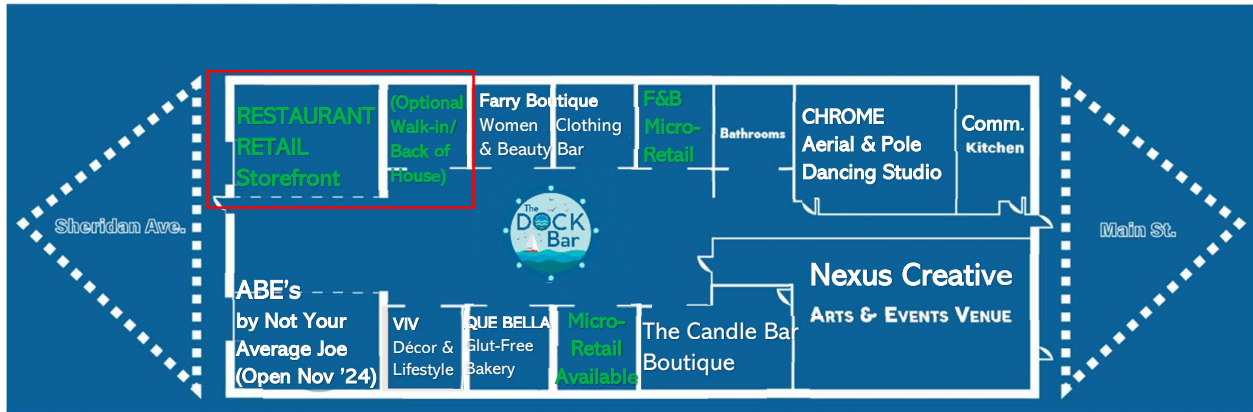

This space offers excellent exposure on Sheridan Ave. (FILM ROW) in Downtown OKC (just 2 blocks west of Myriad Botanical Gardens) with an efficient yet flexible layout for retail/restaurant. With very large display window & operational glass overhead door, it is ideal for outdoor seating option/activation.

It has existing built-in electrical and will come finished w. plumbing and grease trap for a variety of food & beverage concepts. Landlord is open to build-out a vent-hood structure and amortize into lease.

Total square footage including the common areas load factor can range between 1,355 and 1,955 SqFt, including space for walk-in & back of house area. Base Rent starting at \$2470 (\$21.88 PSF) + General CAMs (Approx \$5.5 PSF) \*

### Sheridan Ave / Film Row - Downtown OKC High Exposure Storefront

-Food & Beverage / Restaurant w. Glass Rollup Door & Outdoor Seating Option

-1,355-1,995 SqFt Contiguous Available

-Grease Trap Plumbing & Existing Outlets Available

-Custom Signage Option\*

-Jan-2025 Occupancy



*Pricing does not include building service/op. expenses such as Utilities, Trash Service/Wi-Fi etc.*

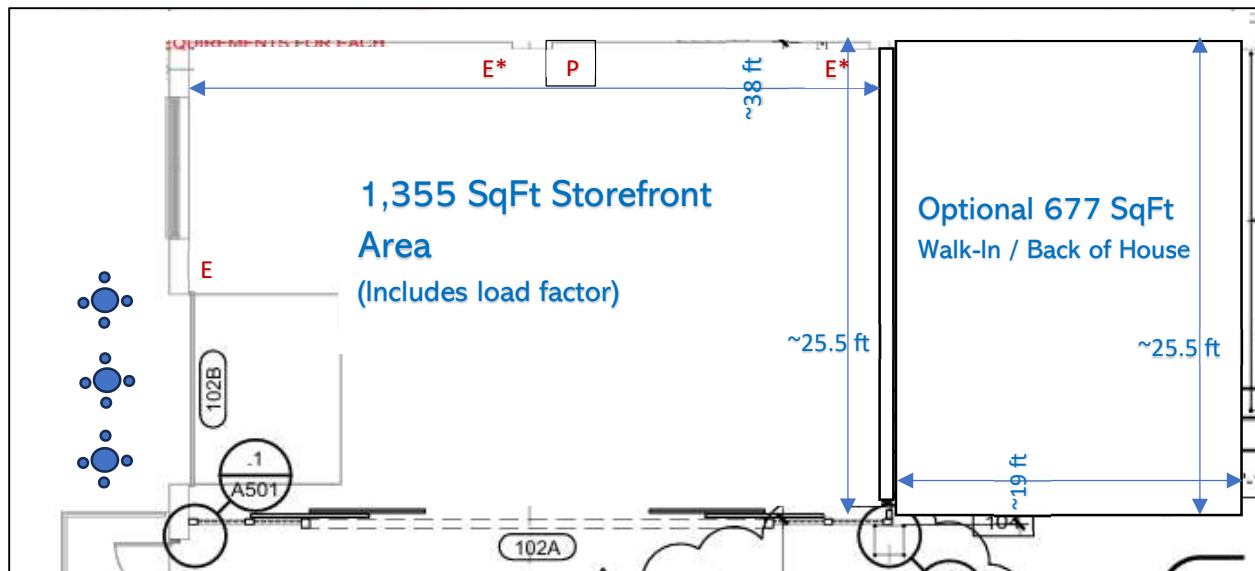

- E** 110 Electrical outlet box
- E\*** 110 Electrical outlet box on dedicated circuit
- P** Plumbing: Water/Sewer/Grease Trap

*Pricing does not include building service/op. expenses such as Utilities, Trash Service/Wi-Fi etc.*

## Proposed future seating plan:

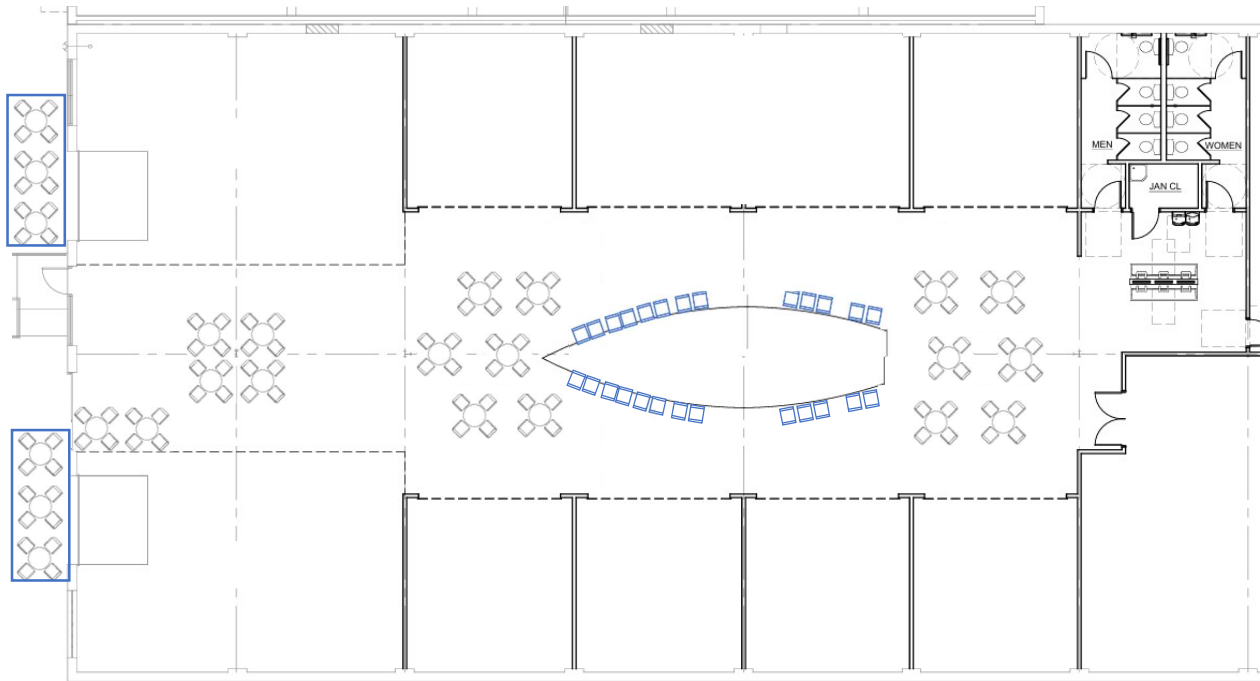

Outdoor seating may be required to be brought in at night, unless permitted.



Ample bar (central sailboat) seating also available during bar hours afternoon/evening.

## Food & Beverage / Micro-Retail Restaurant Space:

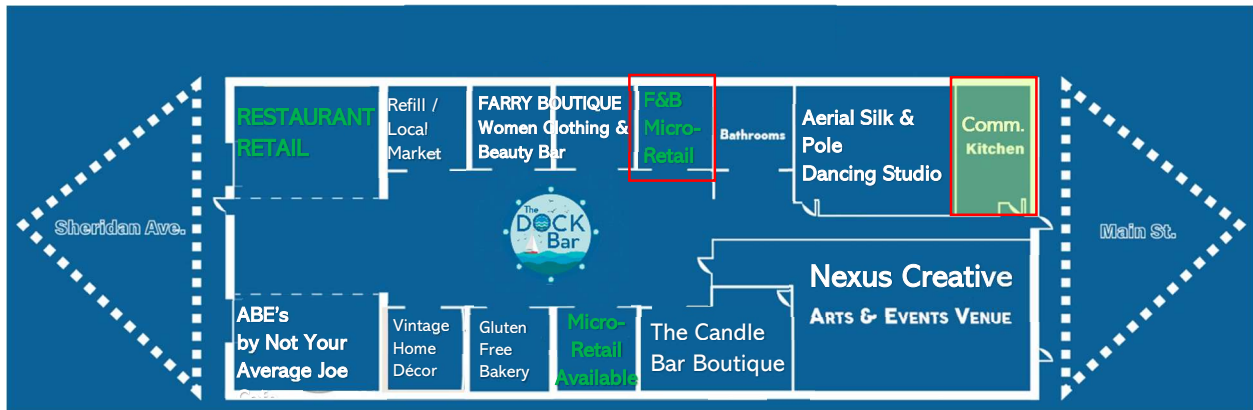

This space is perfect turn-key space for any small efficient F&B restaurant concept. It comes turn-key with plumbing & grease trap (above ground), triple sinks, multiple electrical outlets, and more. Access to back-of house COMMESARY KITCHEN w/ Vent Hood also may be available for small additional cost.

Total square footage including the common areas load factor is 570 SqFt.

Base Rent \$1296 + \$258 General CAMs\*.

**(DISCOUNTS OFFERED ON 2 YR+ Lease)**



*Pricing does not include building service/op. expenses such as Utilities, Trash Service/Wi-Fi etc.*

## Micro-Retail Space:

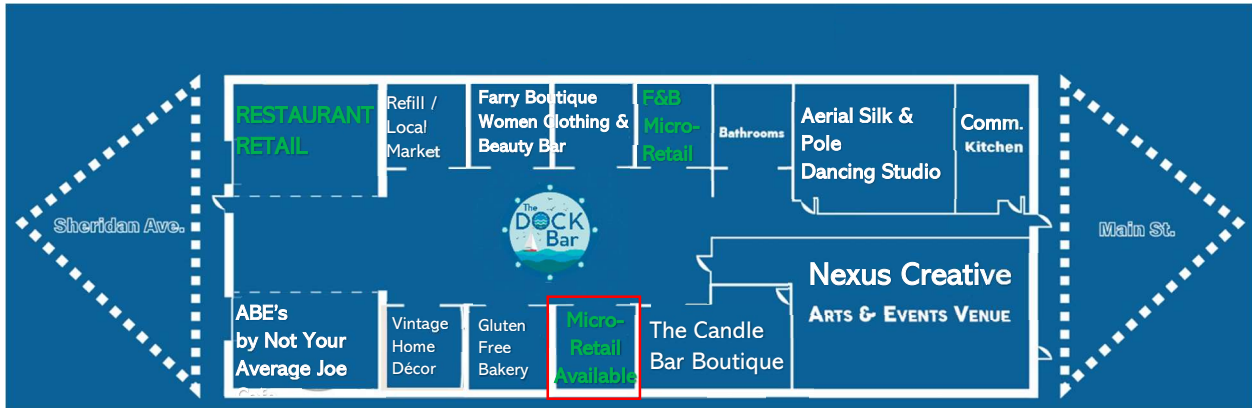

This space is perfect turn-key space for any retail concept. Total square footage including the common areas load factor is 570 SqFt. Base Rent \$1046 + \$258 General CAMs\*.

**(DISCOUNTS OFFERED ON 2 YR+ Lease)**



*Pricing does not include building service/op. expenses such as Utilities, Trash Service/Wi-Fi etc.*