

Office Building for Sublease

1824 East 7th Street • Charlotte, NC 28204

FOR SUBLEASE



Professional + Charming +/- 2,585sf Setting in Elizabeth

Fantastic Opportunity for a Business who Requires a Notable Street Presence!



Clay Durkin

704-858-4508
cd@claydurkin.com



FEATURES

- 6 Privates, Work Rm., Large multi-funct. Rm., 12 parks, 3 Baths, Kitchen, Side Entrance, Lockable 2nd Fl. Suite.
- Sublease ends 5/31/28.
- Excellent walkability to many neighboring shops and restaurants, Conveniently located near the on-ramp for Independence Blvd. (Hwy 74) and less than 1 mile to Uptown Charlotte. Close proximity to Novant Presbyterian & Mercy Hospitals, I-77 & I-277 and Retail & Restaurants along 7th Street, Elizabeth Avenue and Central Avenue.
- Adjacent to the CityLYNX Gold Line Trolley (2 Stops Close by on Hawthorne Ave. = 5th St. + Sunnyside Ave.)
- The Elizabeth Neighborhood is Charlotte's second oldest streetcar suburb and is best known for its historic charm, tree-lined streets and close knit community. The neighborhood is also known for its Craftsman-Style bungalow homes, locally owned businesses, Restaurants & Music Halls.

Every effort has been made to provide accurate and reliable information, but no liability is assumed for errors and omissions. It is your responsibility to conduct a careful investigation of the property to verify this information and determine to your satisfaction the suitability of the property to your needs.

For more info, please visit our "Properties" section at: www.DurkinCommercial.com

Office Building for Lease

1824 East 7th Street • Charlotte, NC 28204

FOR LEASE

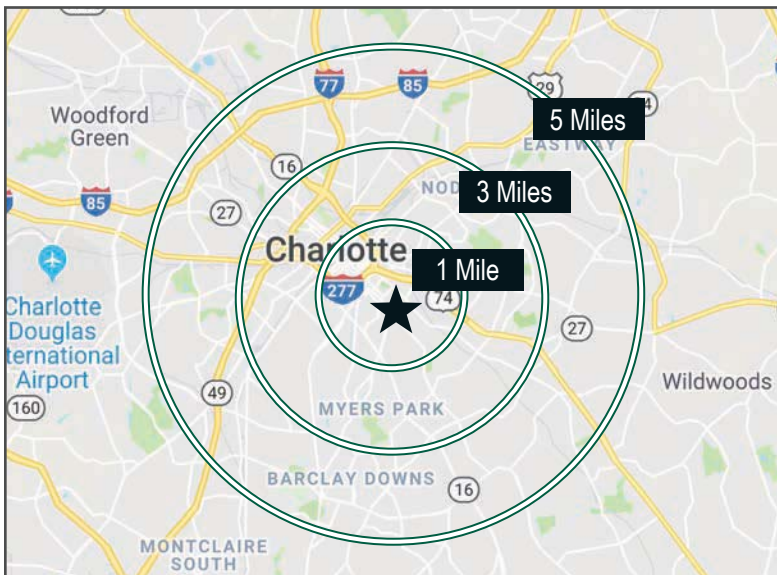
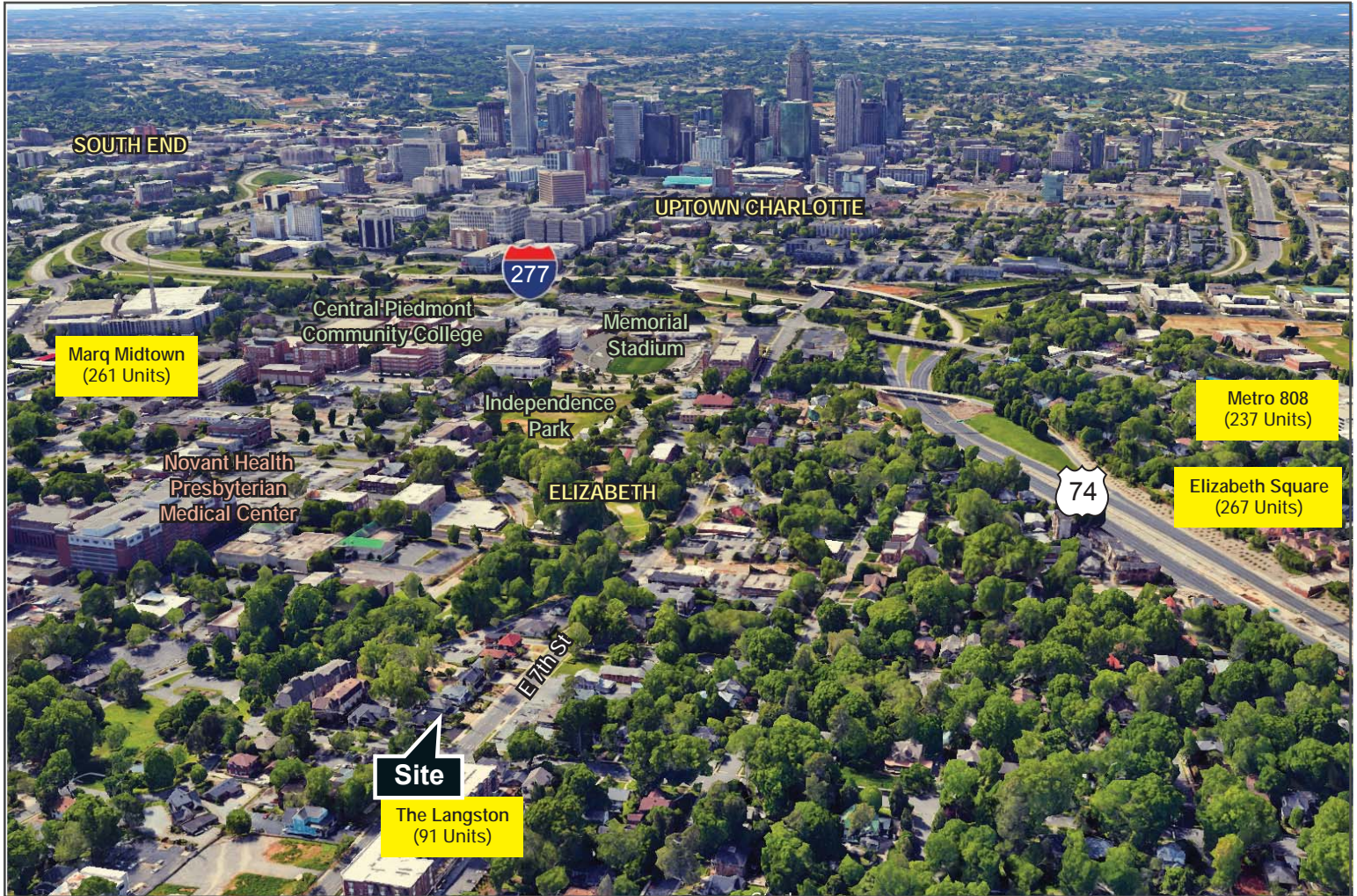

DEMOGRAPHICS			
	1 Mile	3 Miles	5 Miles
2019 Population	20,981	141,380	308,280
2024 Population	23,675	157,546	339,275
Pop. Growth 2019-2024	12.84%	11.43%	10.05%
Average Age	35.30	35.70	36.20
2019 Total Households	10,244	65,439	130,472
HH Growth 2019-2024	13.17%	11.72%	10.17%
Median HH Income	\$71,882	\$68,791	\$53,416
Average HH Size	1.90	2.00	2.30
Median Home Value	\$395,257	\$359,828	\$257,325
Median Year Built	1991	1983	1976

For more info, please visit our "Properties" section at: www.DurkinCommercial.com

Office Building for Lease

1824 East 7th Street • Charlotte, NC 28204

FOR LEASE



LOCAL AMENITIES

- | | |
|--------------------------|-----------------------------|
| 1 MADabolic | 16 Organic Nails by Adriana |
| 2 Unique Boutique | 17 Cajun Queen |
| 3 Sunflour Baking Compan | 18 Hawthorne's NY Pizza |
| 4 Pet Supplies Plus | 19 Visualite Theatre |
| 5 Bang Bang Burgers | 20 Sabor Latin Street Grill |
| 6 Jersey Mike's | 21 The UPS Store |
| 7 Oasis Day Spa | 22 Viva Chicken |
| 8 Showmars | 23 Earl's Grocery |
| 9 Caswell Station | 24 1900 Mexican Grill |
| 10 Starbucks | 25 Fig Tree |
| 11 The Stanley | 26 The Spoke Easy |
| 12 8th Street Studio | 27 Jones Dry Cleaning |
| 13 The Crunkleton | 28 Devil's Logic Brewing |
| 14 Burn Boot Camp | 29 Camille's Sidewalk Cafe |
| 15 2001 Cleaners Inc. | 30 Autobell Car Wash |

LOCATION HIGHLIGHTS

- Excellent walkability to neighboring shops and restaurants, Conveniently located near the on-ramp for Independence Blvd. (Hwy 74) and less than 1 mile to Uptown Charlotte. Close proximity to Novant Presbyterian & Mercy Hospitals, I-77 & I- 277 and Retail & Restaurants along 7th Street, Elizabeth Avenue and Central Avenue.
- The Elizabeth Neighborhood is Charlotte's second oldest streetcar suburb and is best known for its historic charm, treelined streets and close knit community. The neighborhood is also known for its Craftsman-Style bungalow homes, locally owned businesses, Restaurants & Music Halls. The Elizabeth community is a mixture of urban vitality + historic heritage.
- The Neighborhood also Borders prominent Plaza Midwood, Eastover + the Myers Park residential neighborhoods, is 10 minutes from Cotswold and MoRA, 20 minutes from SouthPark and less than 2 miles from Charlotte's Central Business District.
- Property is Just down the street from the CityLYNX Gold Line Trolley + is on a CATS route.

For more info, please visit our "Properties" section at: www.DurkinCommercial.com

Office Building for Lease

1824 East 7th Street • Charlotte, NC 28204

FOR LEASE

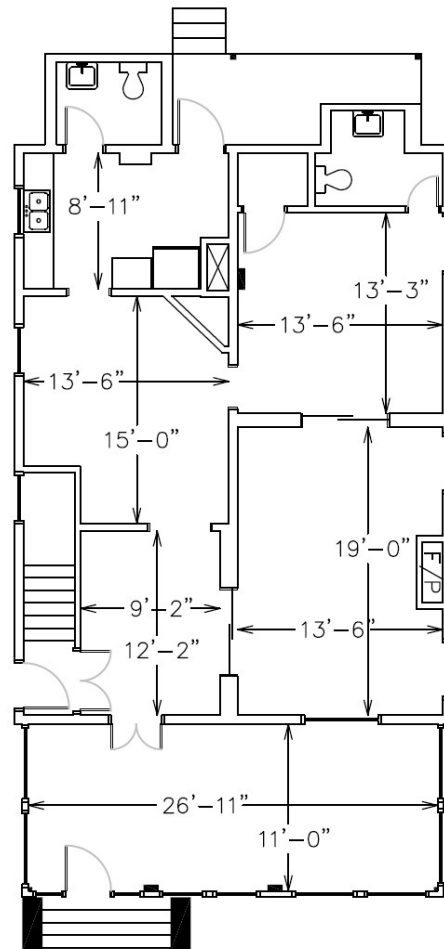
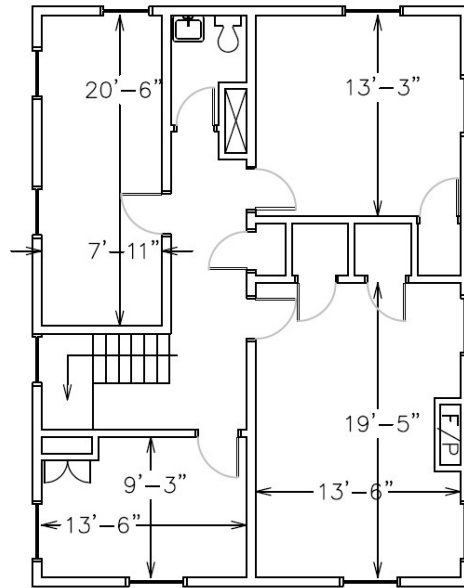

1824 E. 7TH ST
CHARLOTTE NC
2,585 TOTAL GROSS SF

For more info, please visit our "Properties" section at: www.DurkinCommercial.com

Office Building for Lease

1824 East 7th Street • Charlotte, NC 28204

FOR LEASE



For more info, please visit our "Properties" section at: www.DurkinCommercial.com



