



RETAIL SPACE

LONG BEACH, NY

120-134 E PARK AVENUE

SIZE

1,179 SF

ASKING RENT

Upon Request

CO-TENANTS

Margarita's Cafe, Paulina's Hair Salon, Core95, Sue's Nail & Spa, Little Bites Play Cafe, Cover Girl Fashion, Active Life

NEIGHBORS

Stop & Shop, Starbucks, Dunkin', Rite Aid, Subway, Citibank, CrossFit, Baskin Robbins, Burger King, Five Guys, Curves, The Chop Shop, Fresco Creperie & Cafe, Gentle Brew Coffee

COMMENTS

ALL USES CONSIDERED

Former Salon Space

1/4 mile from LIRR Station

Ample Parking

CONTACT EXCLUSIVE AGENTS

JASON SOBEL

jsobel@ripcony.com

516.933.8880

JULIANA CHIARELLI

jchiarelli@ripcony.com

516.933.8880

RIPCO
REAL ESTATE

1000 Woodbury Road
Suite 100
Woodbury, NY 11797
516.933.8880

Please visit us at ripcony.com for more information

This information has been secured from sources we believe to be reliable, but we make no representations as to the accuracy of the information. References to square footage are approximate. Buyer must verify the information and bears all risk for any inaccuracies.

PHOTOS



FLOOR PLAN

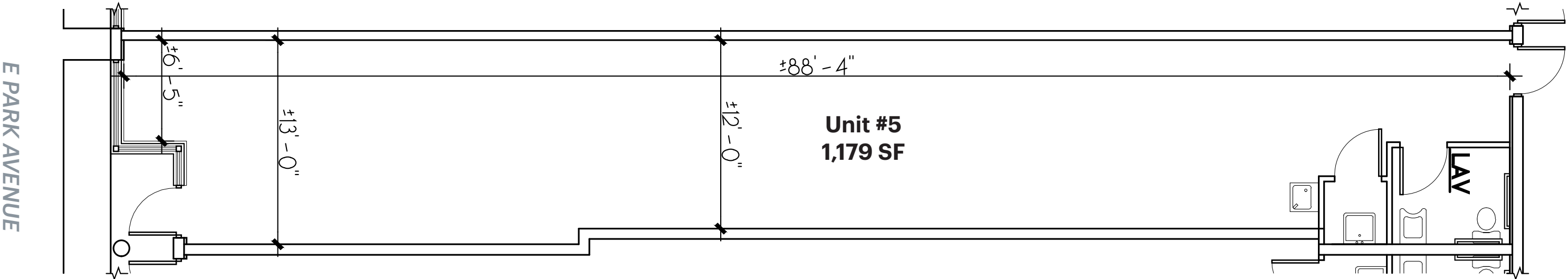

MARKET AERIAL

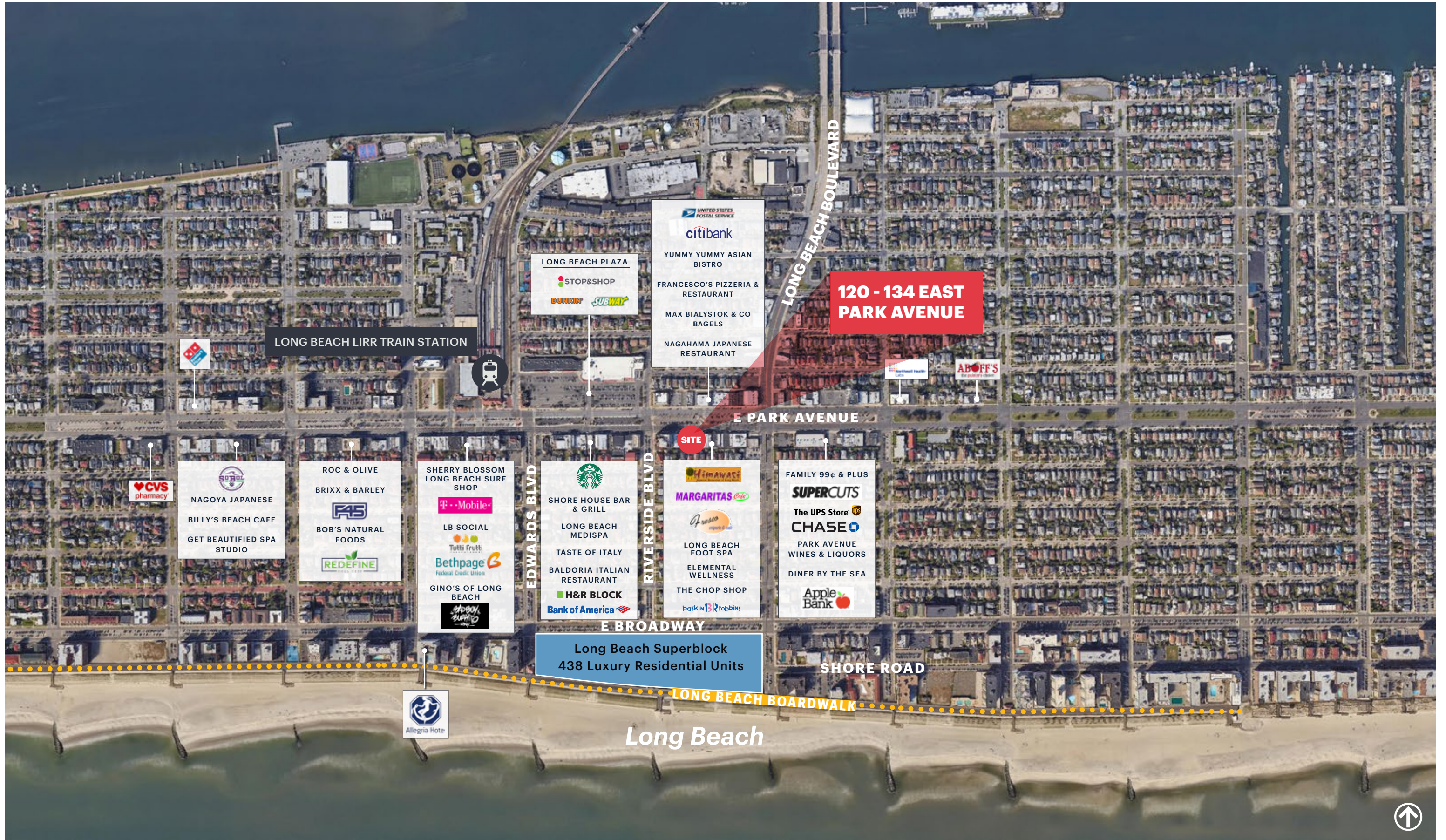

120 - 134 EAST PARK AVENUE

UNITED STATES POSTAL SERVICE
citibank
 YUMMY YUMMY ASIAN BISTRO
 FRANCESCO'S PIZZERIA & RESTAURANT
 MAX BIALYSTOK & CO BAGELS
 NAGAHAMA JAPANESE RESTAURANT

LONG BEACH PLAZA
 STOP&SHOP
 DUNKIN' SUBWAY

LONG BEACH LIRR TRAIN STATION

E PARK AVENUE

SITE

CVS pharmacy

NAGOYA JAPANESE
 BILLY'S BEACH CAFE
 GET BEAUTIFIED SPA STUDIO

ROC & OLIVE
 BRIXX & BARLEY
 F45
 BOB'S NATURAL FOODS
 REDEFINE

SHERRY BLOSSOM LONG BEACH SURF SHOP
 T-Mobile
 LB SOCIAL
 Tutti Frutti
 Bethpage Federal Credit Union
 GINO'S OF LONG BEACH

STARBUCKS
 SHORE HOUSE BAR & GRILL
 LONG BEACH MEDISPA
 TASTE OF ITALY
 BALDORIA ITALIAN RESTAURANT
 H&R BLOCK
 Bank of America

HIMAWASE
 MARGARITAS
 Fresco
 LONG BEACH FOOT SPA
 ELEMENTAL WELLNESS
 THE CHOP SHOP
 baskin robbins

FAMILY 99¢ & PLUS
 SUPERCUTS
 The UPS Store
 CHASE
 PARK AVENUE WINES & LIQUORS
 DINER BY THE SEA
 Apple Bank

Long Beach Superblock
 438 Luxury Residential Units

SHORE ROAD

LONG BEACH BOARDWALK

Long Beach

Allegria Hotel



AREA DEMOGRAPHICS

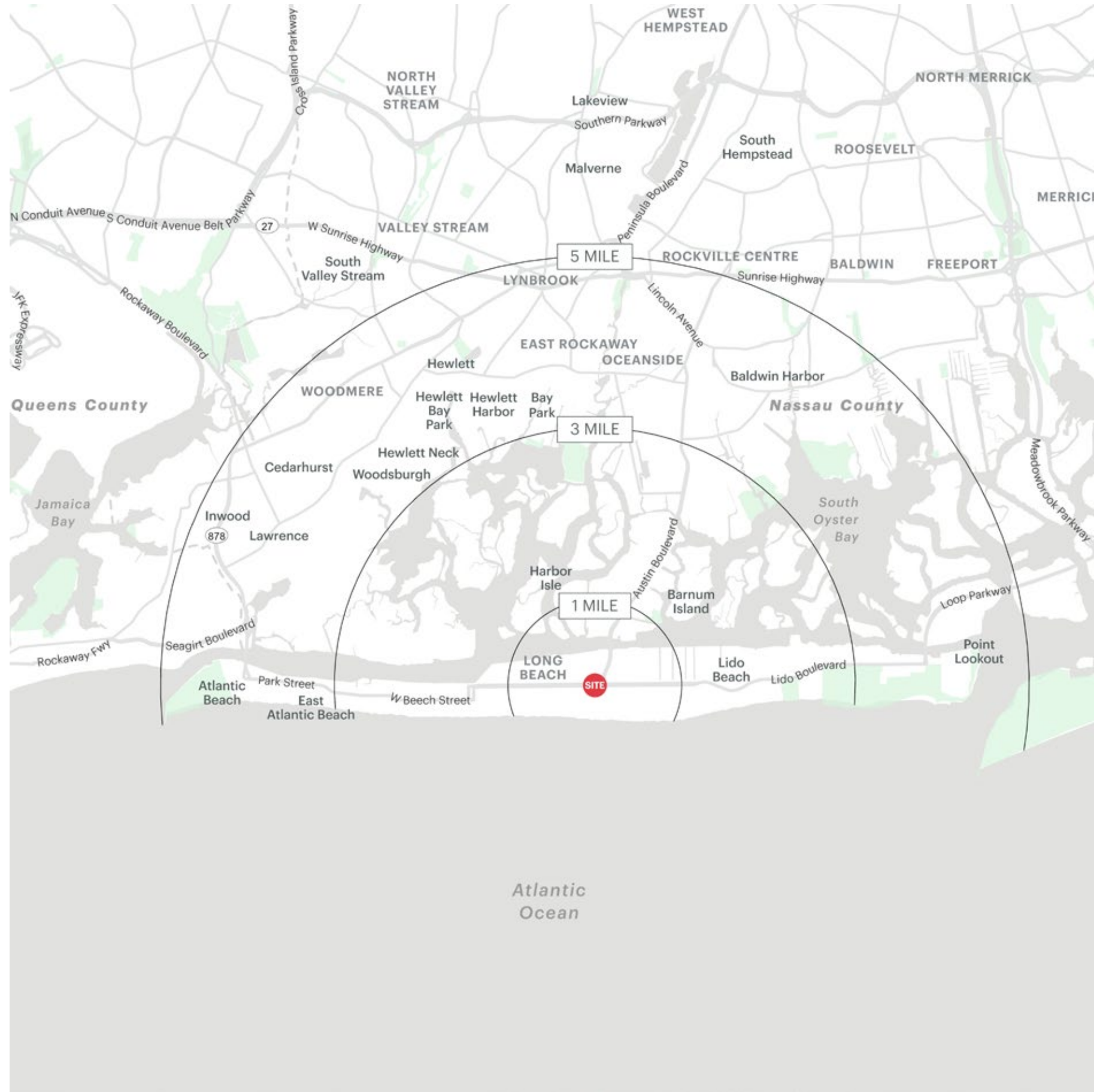

1 MILE RADIUS

POPULATION

27,366

HOUSEHOLDS

11,663

AVERAGE HOUSEHOLD INCOME

\$160,171

MEDIAN HOUSEHOLD INCOME

\$118,215

COLLEGE GRADUATES (BACHELOR'S +)

10,612 - 50.0%

TOTAL BUSINESSES

860

TOTAL EMPLOYEES

7,455

DAYTIME POPULATION (W/ 16 YR +)

19,388

3 MILE RADIUS

POPULATION

57,783

HOUSEHOLDS

23,872

AVERAGE HOUSEHOLD INCOME

\$170,126

MEDIAN HOUSEHOLD INCOME

\$124,447

COLLEGE GRADUATES (BACHELOR'S +)

22,310 - 50.0%

TOTAL BUSINESSES

1,996

TOTAL EMPLOYEES

18,330

DAYTIME POPULATION (W/ 16 YR +)

44,212

5 MILE RADIUS

POPULATION

210,977

HOUSEHOLDS

76,233

AVERAGE HOUSEHOLD INCOME

\$169,252

MEDIAN HOUSEHOLD INCOME

\$120,541

COLLEGE GRADUATES (BACHELOR'S +)

74,186 - 50.0%

TOTAL BUSINESSES

8,704

TOTAL EMPLOYEES

74,941

DAYTIME POPULATION (W/ 16 YR +)

182,543

AREA DEMOGRAPHICS

