

# FOR LEASE - Lab / Office / Industrial

410 Sackett Point Road • North Haven, CT

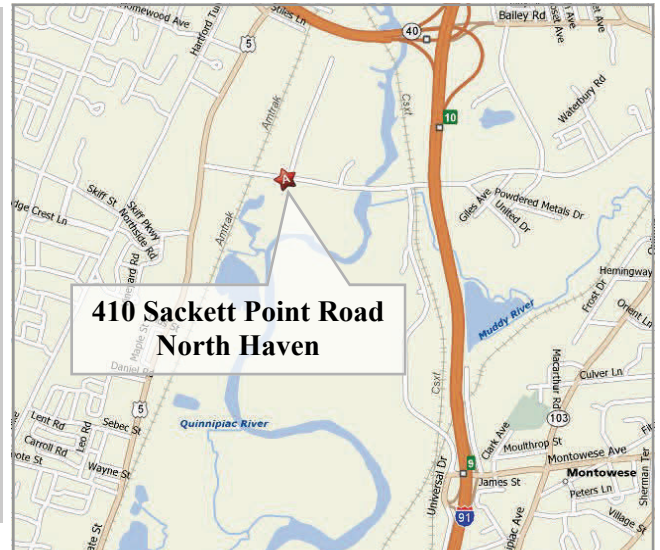

PHOENIX RESEARCH PARK



State Street (North Haven) to Sackett Point Road

<b><u>Buildings</u></b>	5 Buildings
<b>Total Building</b>	104,000 SF
<b>Stories</b>	1
<b>Available SF</b>	63,570 SF
25,270 SF	Warehouse / Flex / Mfg.
38,300 SF	Lab / Mixed Office
<b>Minimum</b>	2,500 SF
<b>Ceiling Height</b>	12' to 20' (varies)
<b>Construction</b>	Masonry
<b>Year Built</b>	1975
<b>Overhead Doors</b>	3
<b>Drive-in Doors</b>	2
<b>Docks</b>	1
<b><u>Mechanicals</u></b>	
<b>Type of Heat</b>	Gas
<b>Sprinklered</b>	Yes
<b>Electric Service</b>	Heavy Power Available / 3 Phase

<b><u>Site</u></b>	
<b>Acres</b>	14
<b>Zoning</b>	IG-80
<b>Parking</b>	Open
<b>Highway Access</b>	I-91, Exits 9 or 10 and Wilbur Cross Parkway
<b><u>Utilities</u></b>	City water and sewers / Gas

<b><u>Assessment</u></b>	
<b>Total Assessment</b>	\$2,635,640
<b>Taxes</b>	\$77,541
<b>Assessment Year</b>	2015
<b>Mill Rate</b>	29.42

**Lease Rates**  
**\$5.00/SF NNN Warehouse Space**  
**Lab Space from \$8.50/SF NNN**

**Remarks:** AVAILABLE SPACE - 25,270 SF of warehouse / flex / manufacturing and 38,300 SF of lab / mixed office. Convenient to I-91, Exit 10 and Wilbur Cross Parkway (8 miles from New Haven and Yale University). Wet laboratory space available, heavy power and rail access possible.

For additional information contact:

**Joel Nesson, Senior Advisor**  
**203.288.1900, x131**  
**jnesson@presscuozzo.com**

2751 Dixwell Avenue • Hamden, Connecticut 06518 • 203-288-1900 • Fax 203-288-0100  
Email: info@presscuozzo.com  
[www.presscuozzo.com](http://www.presscuozzo.com)

**Press|Cuozzo**  
REALTORS  
Commercial Services

The information above is offered subject to errors, omissions, price change, prior sale, lease or withdrawal from market.

# PHOENIX RESEARCH PARK

## Building Layout

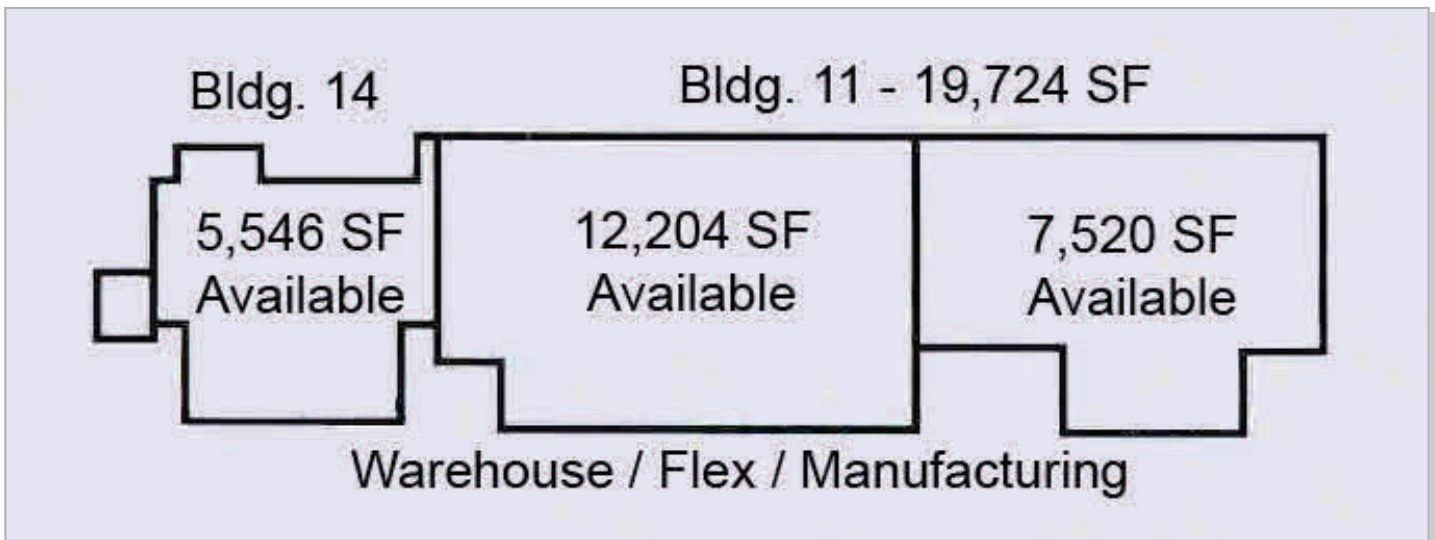
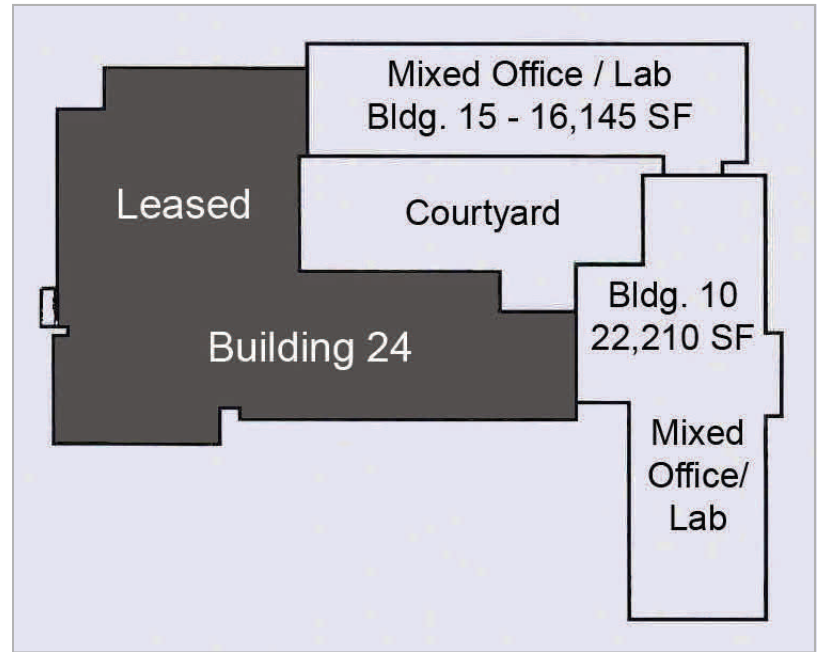

**Joel Nesson**  
203.288.1900, x131  
jnesson@presscuozzo.com