



FOR LEASE

GARLINGTON PARK: 2 UNITS ±832 - 1,184 SF FLEX SPACE

319 Garlington Road
Greenville, SC 29615



LEE & ASSOCIATES
GREENVILLE/SPARTANBURG

Kevin Bentley, SIOR
EVP/Principal
864.444.1196
kbentley@lee-associates.com

Justin Bentley
Associate
864.449.1059
jbentley@lee-associates.com

Interactive PDF 

864.704.1040
LeeUpstate.com

PRICING/RATE:
\$13/SF

- Under New Management
- Prime Location
- Easy Highway Access
- 2 Units Available
D-9 ±1,184 SF, and D-12 ±832 SF

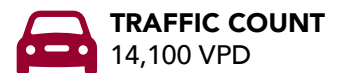
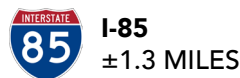
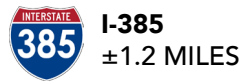

PROPERTY OVERVIEW & PHOTOS

PROPERTY NAME	Garlington Park
TYPE	Flex
TOTAL AVAILABLE SF	D-9 ±1,184 SF D-12 ±832 SF
TOTAL BUILDING SF	±20,000 SF
TAX MAP #	0547030100138
COUNTY	Greenville
CITY LIMITS	Greenville
ZONING	IX
YEAR BUILT	2004
CONSTRUCTION TYPE	Masonry
OFFICE SF	±2,848 SF
UTILITIES	All
PARKING	1.13 Per 1,000 SF
SPRINKLERS	Wet



LOCATION OVERVIEW

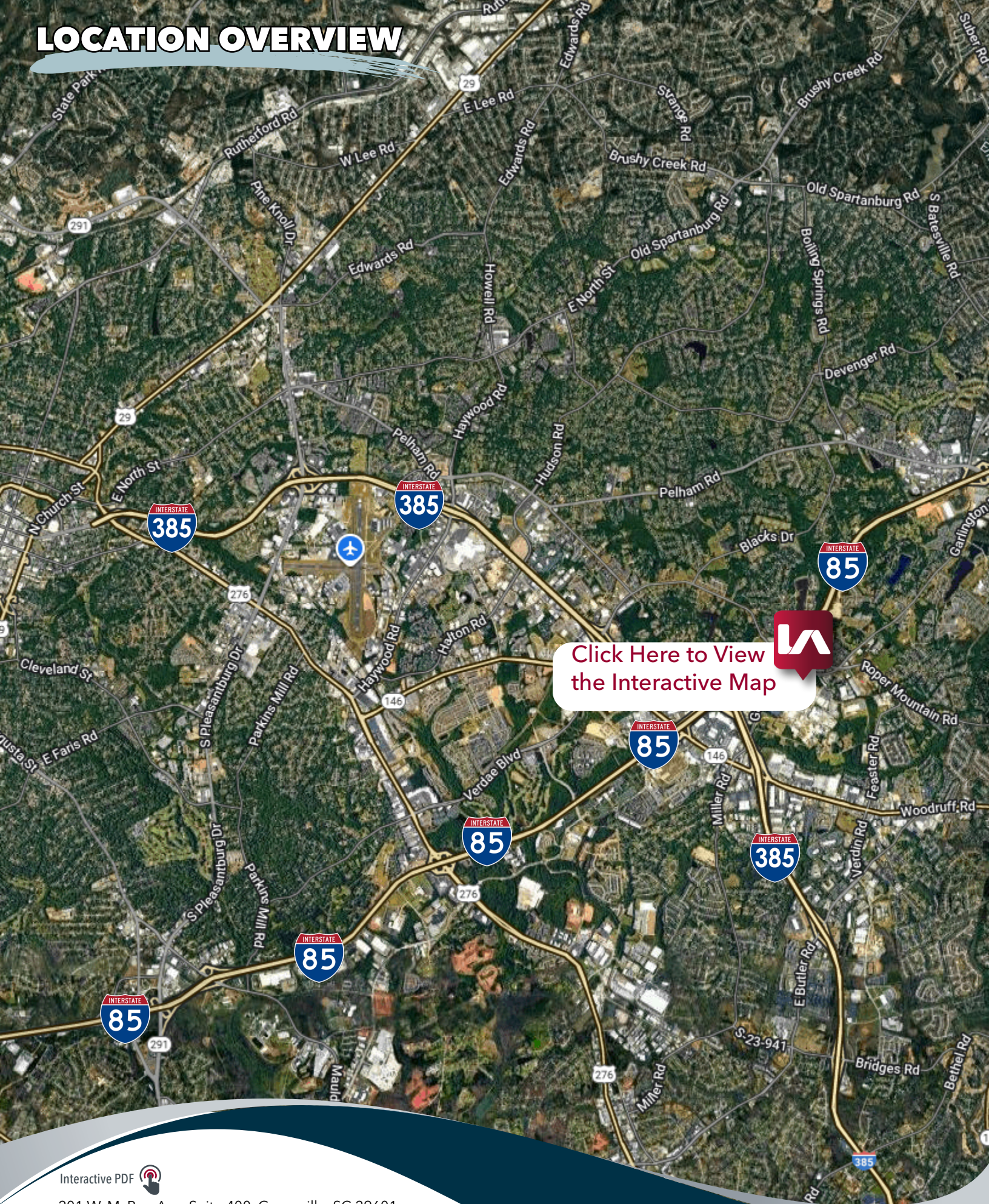

Interactive PDF 

201 W. McBee Ave, Suite 400, Greenville, SC 29601
320 E. Main Street, Suite 430, Spartanburg, SC 29302
LeeUpstate.com | 864.704.1040

FLOOR PLANS

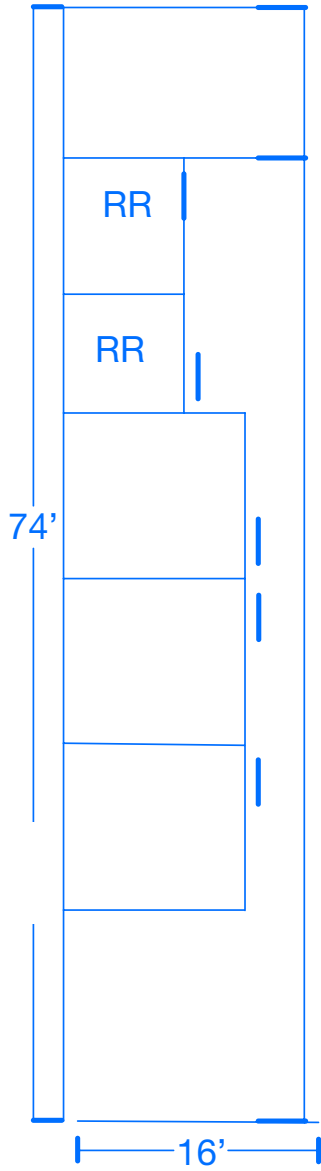

1,184 SF

D-9

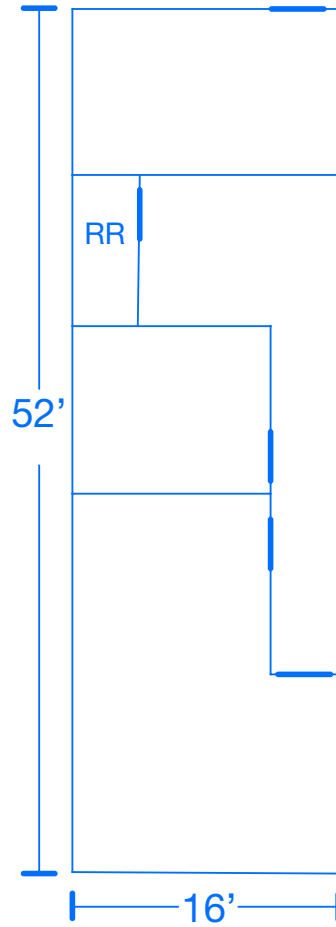

832 SF

D-12





LEARN MORE CALL TODAY



LEE & ASSOCIATES
GREENVILLE/SPARTANBURG

864.704.1040
LeeUpstate.com

GREENVILLE OFFICE
201 W. McBee Ave, Suite 400
Greenville, SC 29601

SPARTANBURG OFFICE
320 E. Main Street, Suite 430
Spartanburg, SC 29302

All information furnished regarding the properties and information in this packet is from sources deemed reliable, but no warranty or representation is made to the accuracy thereof and same is submitted to errors, omissions, change of price, rental or other conditions prior to sale, lease or financing or withdrawal without notice. No liability of any kind is to be imposed on the broker herein.



Kevin Bentley, SIOR



 **864.444.1196**

EVP/Principal
kbentley@lee-associates.com

Interactive PDF 



Justin Bentley



 **864.449.1059**

Associate
jbentley@lee-associates.com