

LEASE

PRIME TWO-STORY RETAIL WITH PARKING IN ULTRA-DESIRABLE WALTHAM

205 Lexington Wlatham, MA 02452



PROPERTY DESCRIPTION

Rarely available high visibility two-story retail space in prime Waltham location with parking. Huge windows and signage along busy Lexington Street surrounded by major local and national shopping and dining and minutes away from top ranked Bently University with 4,000+ students. Excellent width and depth.

PROPERTY HIGHLIGHTS

- High visibility location with excellent windows and signage.,
- Minutes to major highways and surrounded by strong retail

OFFERING SUMMARY

Lease Rate:	\$6,500.00 per month (NNN)
Number of Units:	3
Available SF:	3,500 SF
Lot Size:	7,288 SF
Building Size:	5,380 SF

DEMOGRAPHICS	0.3 MILES	0.5 MILES	1 MILE
Total Households	537	2,087	9,109
Total Population	1,213	4,779	22,004
Average HH Income	\$105,475	\$117,954	\$138,426

Todd Glaskin
Sales Associate
617 843 5685

Richard Dore
617 285 5044



COLDWELL BANKER
COMMERCIAL
REALTY

LEASE

PRIME TWO-STORY RETAIL WITH PARKING IN ULTRA-DESIRABLE WALTHAM

205 Lexington Wlatham, MA 02452



Todd Glaskin
Sales Associate
617 843 5685

Richard Dore
617 285 5044



COLDWELL BANKER
COMMERCIAL
REALTY

LEASE

PRIME TWO-STORY RETAIL WITH PARKING IN ULTRA-DESIRABLE WALTHAM

205 Lexington Waltham, MA 02452



Todd Glaskin
Sales Associate
617 843 5685

Richard Dore
617 285 5044



205 LEXINGTON STREET, WALTHAM

FIRST FLOOR

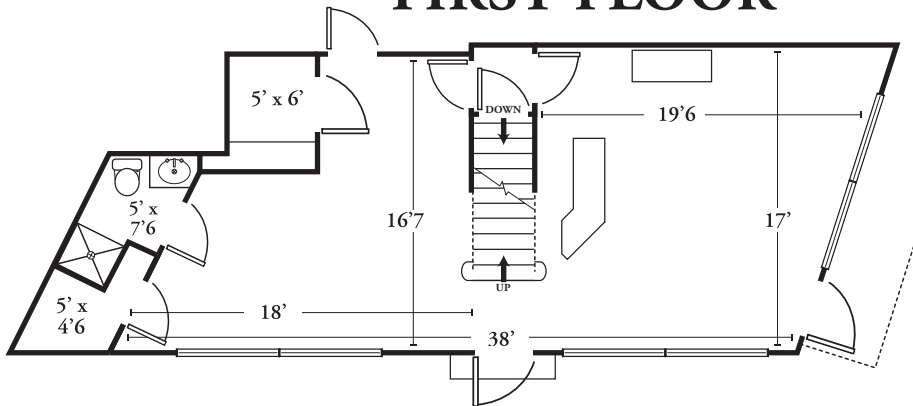

SECOND FLOOR

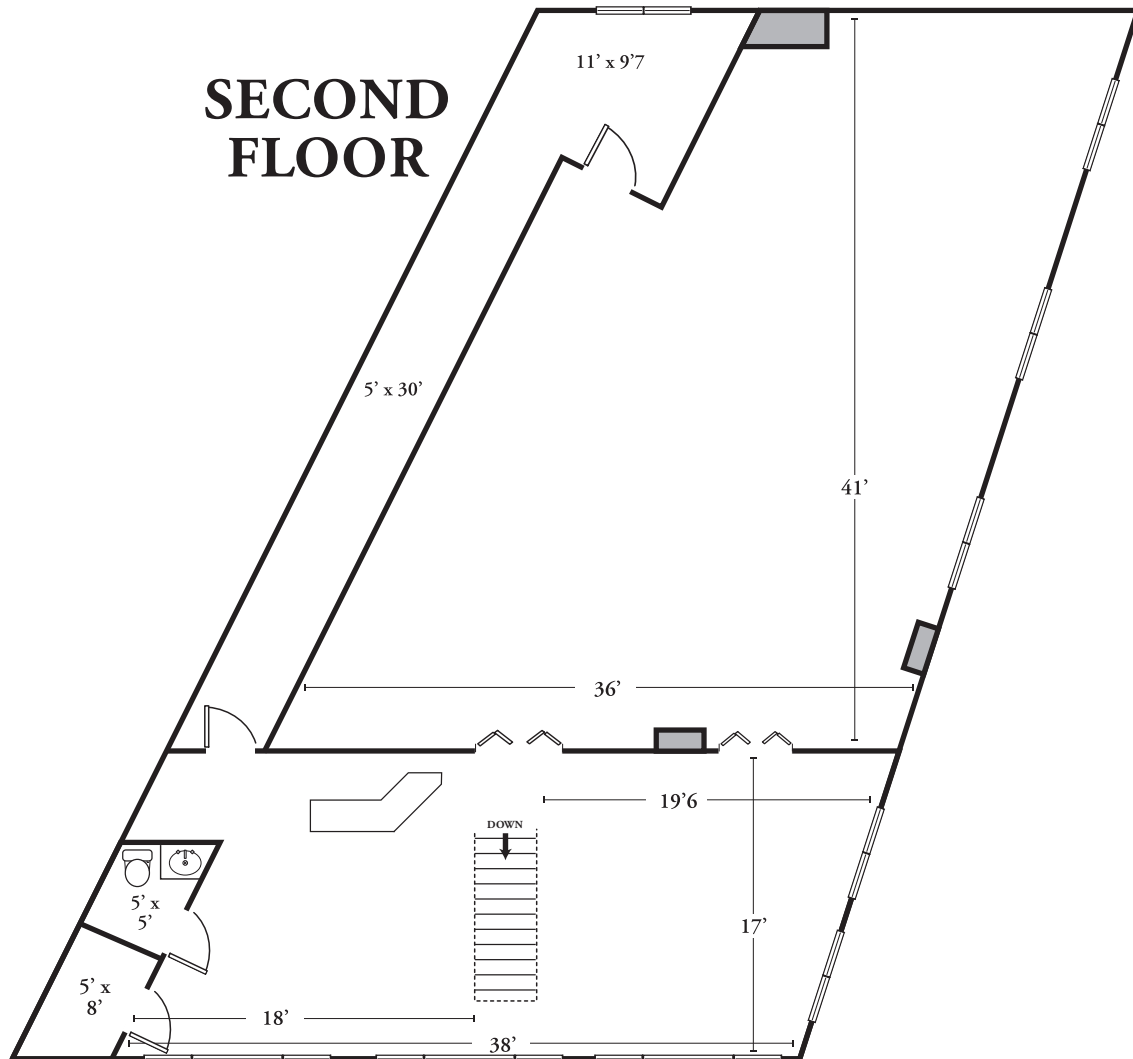

© 2019

David Ward | thecreativeward.com | 617-828-3171
These plans are for marketing purposes only and to provide general information.
Floor plans and dimensions are approximate.

LEASE

PRIME TWO-STORY RETAIL WITH PARKING IN ULTRA-DESIRABLE WALTHAM

205 Lexington Wlatham, MA 02452



Todd Glaskin
Sales Associate
617 843 5685

Richard Dore
617 285 5044



COLDWELL BANKER
COMMERCIAL
REALTY

LEASE

PRIME TWO-STORY RETAIL WITH PARKING IN ULTRA-DESIRABLE WALTHAM

205 Lexington Wlatham, MA 02452

POPULATION	0.3 MILES	0.5 MILES	1 MILE
Total Population	1,213	4,779	22,004
Average Age	41	41	40
Average Age (Male)	0	0	0
Average Age (Female)	0	0	0

HOUSEHOLDS & INCOME	0.3 MILES	0.5 MILES	1 MILE
Total Households	537	2,087	9,109
# of Persons per HH	2.3	2.3	2.4
Average HH Income	\$105,475	\$117,954	\$138,426
Average House Value	\$760,118	\$784,192	\$755,315

Demographics data derived from AlphaMap

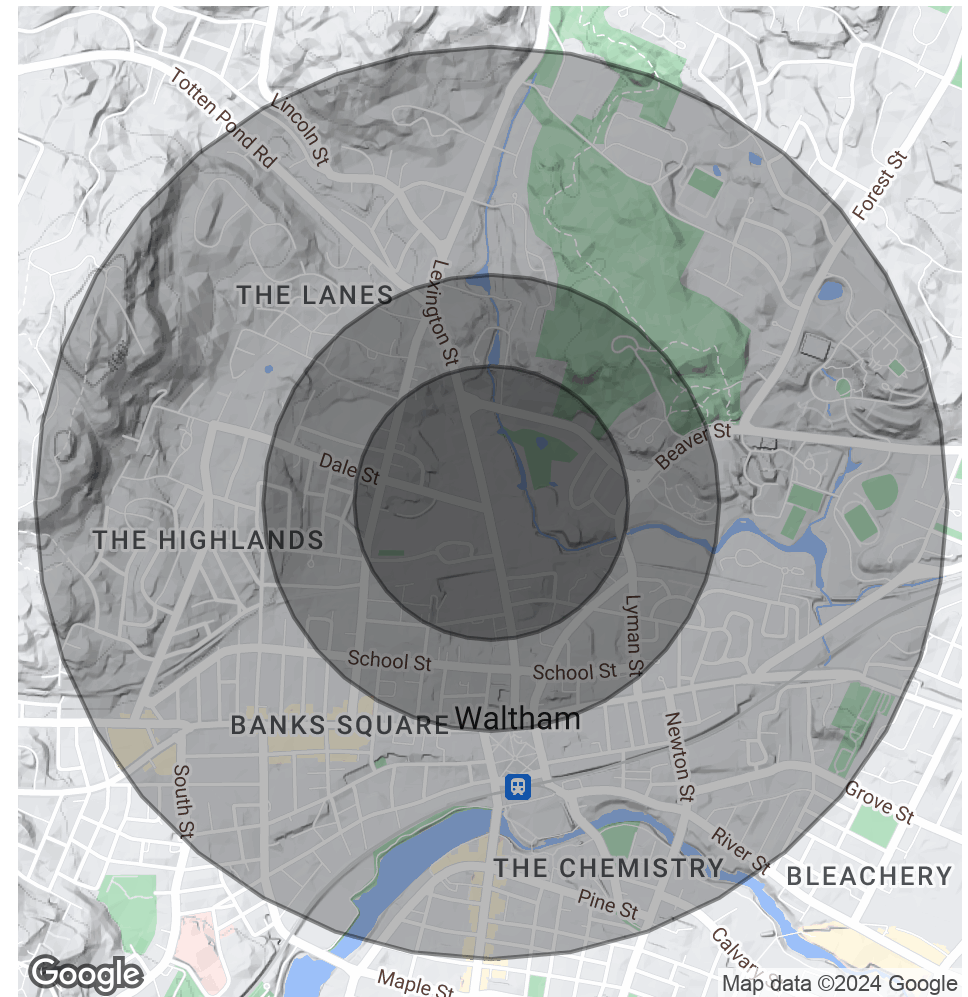

Todd Glaskin
Sales Associate
617 843 5685

Richard Dore
617 285 5044



COLDWELL BANKER
COMMERCIAL
REALTY