



Métro de l'Église à 1 minute à pied
1-minute walk to de l'Église metro station

4028-4030, rue Wellington, Montréal (Québec) H4G 1V3

Espace commercial de 2 084 pi² au rez-de-chaussée, situé directement sur l'artère principale de Verdun
2,084 ft² ground-floor retail space, located directly on Verdun's main thoroughfare

Aucune demande de restauration ne sera considérée
No catering requests will be considered

Pour plus d'informations contactez :
For more information contact :

Richard Sauvé, CCIM, SIOR

Vice-président principal
Courtier immobilier agréé - Commercial
Immobilier Richard Sauvé inc.

☎ 514 866 3333 x234

☎ 514 212 0133

✉ rsauve@naiterramont.ca

Anne-Marie B. Sauvé, BAA

Vice présidente
Courtier immobilier - Commercial
Immobilier Anne-Marie B Sauvé inc.

☎ 514 866 3333 x263

☎ 514 779 4453

✉ amsauve@naiterramont.ca

Caractéristiques de l'espace | Space Features



Superficie (pi²) | Area (ft²)
Rez-de-chaussée | Ground Floor

2 084

Disponibilité | Availability

Immédiate | Now

Possibilité de louer | Possibility of leasing
2^e étage | 2nd Floor*

2 571



Taux de location net net net (\$|pi²) | Net net net rental rate (\$|ft²)
Frais d'exploitation estimés 2023 (\$|pi²)
Estimated operating expenses 2023 (\$|ft²)

34,00 \$
8,00 \$



Hauteur libre | Clear height
10' - 12'



Entrée électrique
Electric entry
200 A



stm
Autobus | Bus: 12, 37, 58, 61, 350
Métro | Metro: De l'Église, Verdun



Air climatisé | Air conditioning
Oui | Yes



Stationnement | Parking
Stationnement à étages Éthel
Éthel multi-storey car park



*Système d'alarme | Alarm system
Oui | Yes
*Appartient au locataire actuel
Belongs to the current tenant

Indice de marche
Walk Score
97

Indice de transport
Transit Score
85

Indice de vélo
Bike Score
97

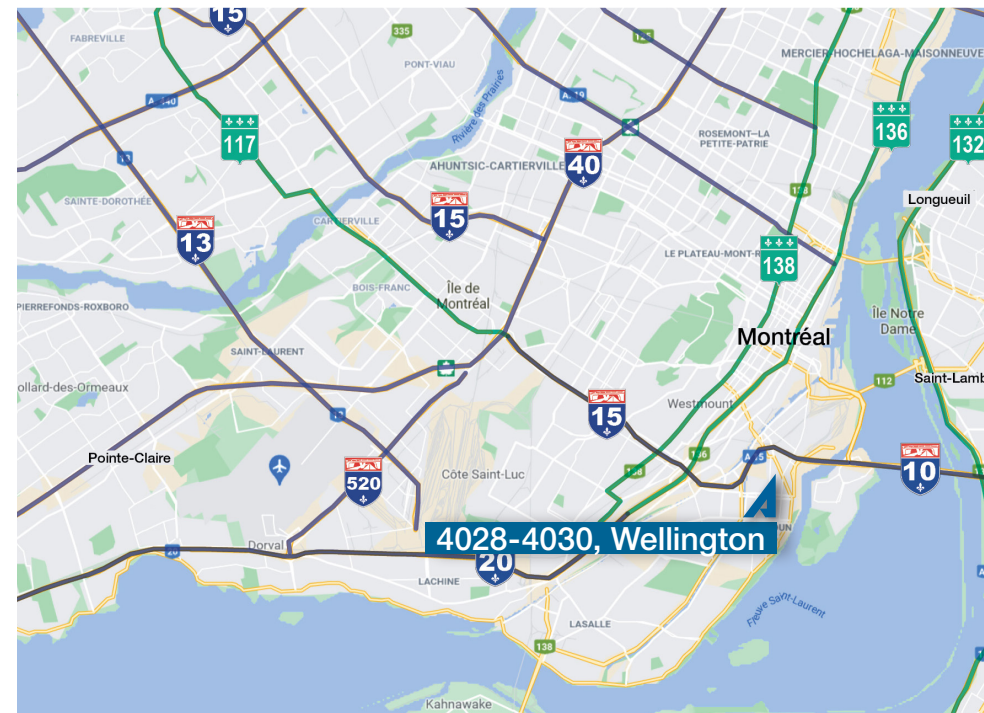

Faits saillants | Highlights



- Bâtiment en excellente condition | Building in excellent condition
- Excellente visibilité | Excellent visibility
- Enseigne sur façade | Sign on facade
- Possibilité d'un système d'alarme aux frais du locataire
Possibility of an alarm system at the tenant's expense
- Rue hautement piétonnière | Highly pedestrianized street
- Face à une aire de stationnements étagés de la ville (179 espaces)
Facing the city's multi-storey car parks (179 spaces)
- Façade complètement vitrée | Fully glazed facade
- Espace lumineux | Luminous space
- Espace d'entreposage additionnel au sous-sol
Additional basement storage space





Plan du rez-de-chaussée | Ground Floor Plan

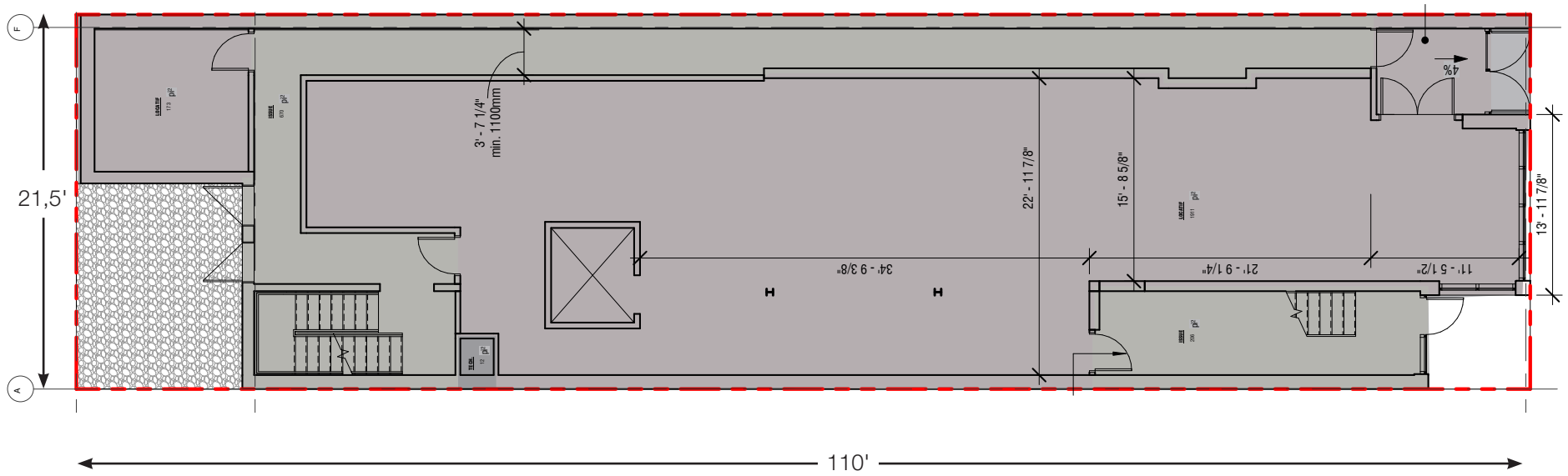

Plan au certificat de localisation | Survey Plan



RUE WELLINGTON

