

security vault works
 980 Western Drive
 Indianapolis, IN 46241
 Phone 317/271.1130
 Fax 317/271.1596

Huntington Bank-Tallmadge
 505 South Ave.
 Tallmadge, OH 44278

Site Plan

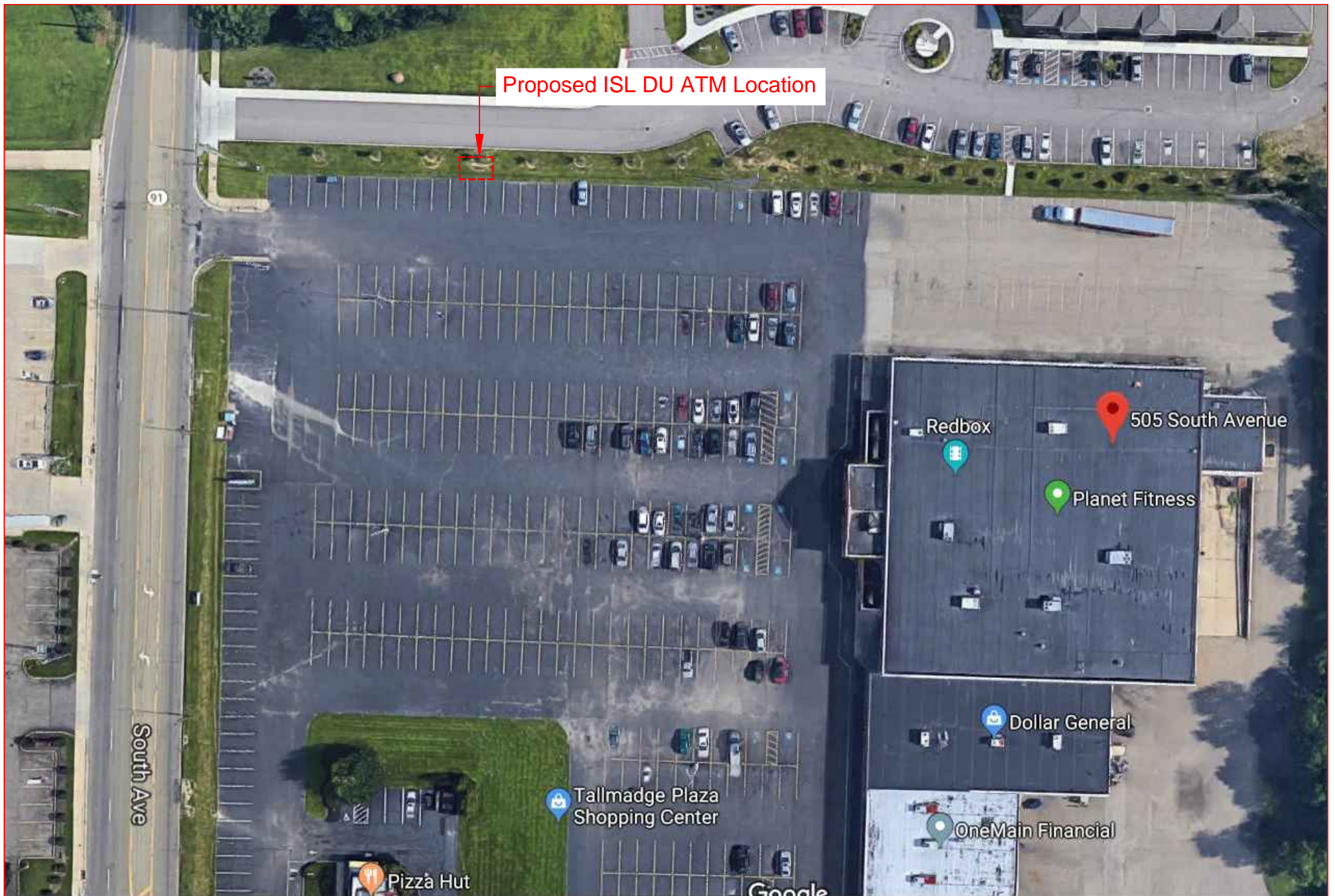

Proposed ISL DU ATM Location

Redbox

505 South Avenue

Planet Fitness

Dollar General

Tallmadge Plaza Shopping Center

OneMain Financial

Pizza Hut

South Ave

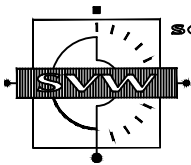

security vault works

980 Western Drive
Indianapolis, IN 46241
Phone 317/271.1130
Fax 317/271.1596

Huntington Bank-Tallmadge
505 South Ave.
Tallmadge, OH 44278

Aerial Photo



(E) Power and Data Location

(E) Landscape

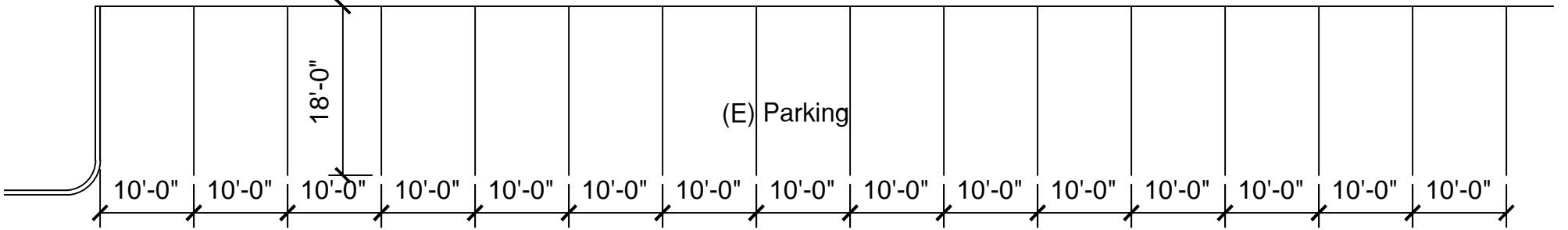

(E) Parking

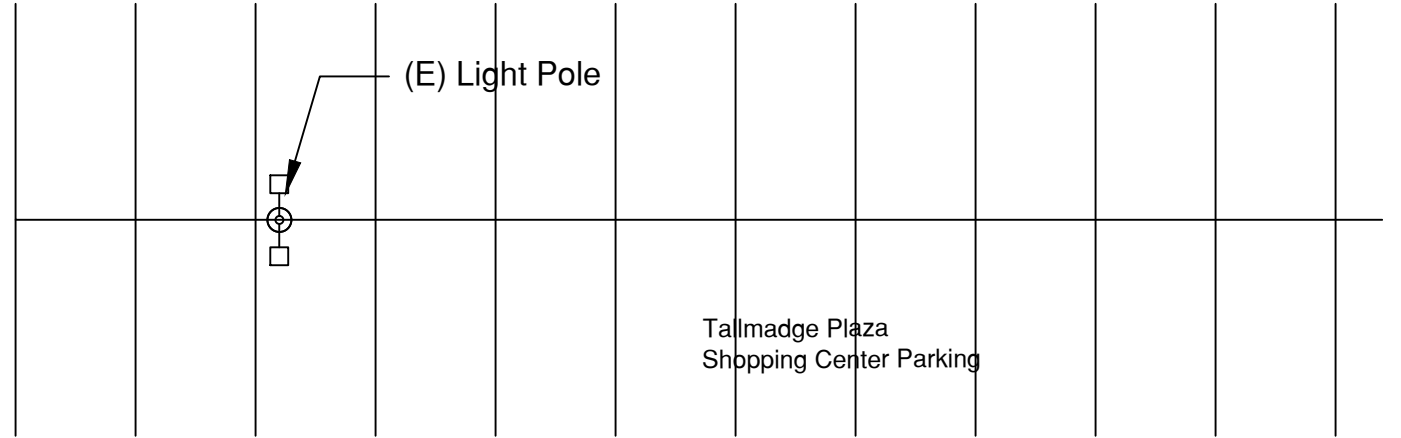
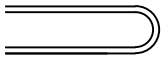

(E) Light Pole

Tallmadge Plaza
Shopping Center Parking

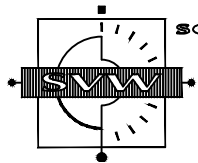

security vault works

980 Western Drive
Indianapolis, IN 46241
Phone 317/271.1130
Fax 317/271.1596

Huntington Bank-Lafayette Square
4618 W. 38th Street
Indianapolis, Illinois 46254

Existing Plan

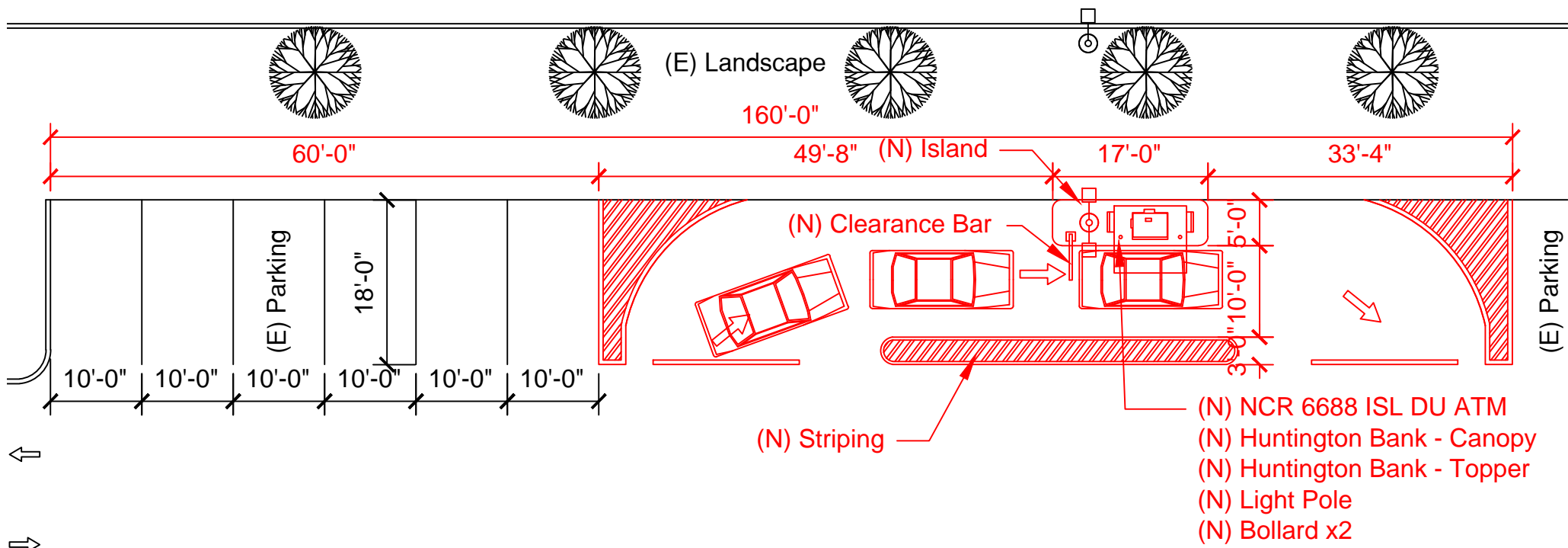

10 Parking Spaces to be removed
to accommodate New Island and ATM lane

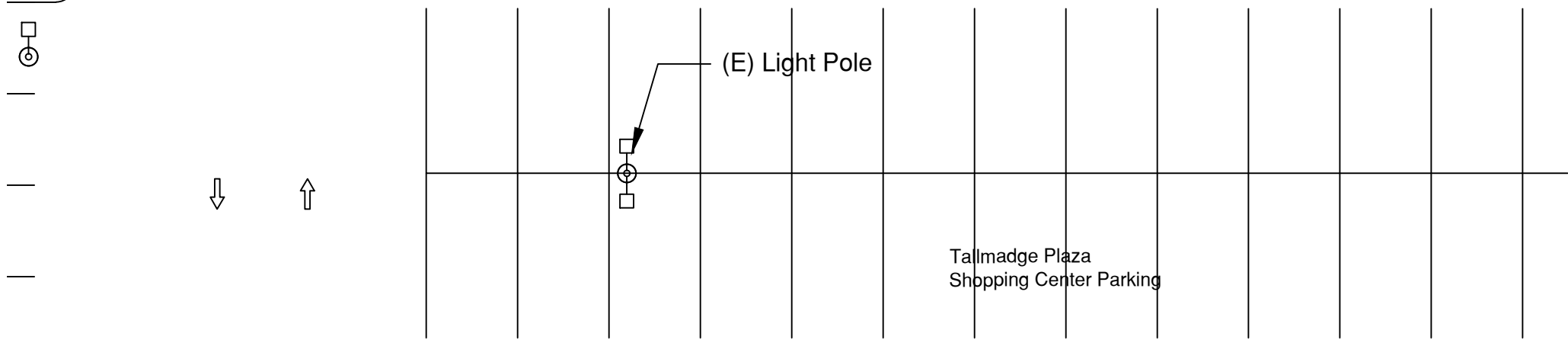

security vault works

980 Western Drive
Indianapolis, IN 46241
Phone 317/271.1130
Fax 317/271.1596

Huntington Bank-Tallmadge
505 South Ave.
Tallmadge, OH 44278

Proposed Plan

(E) Asphalt/ Parking

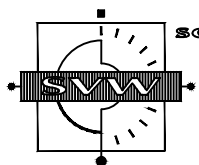
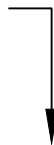

**security vault
works**

980 Western Drive
Indianapolis, IN 46241
Phone 317/271.1130
Fax 317/271.1596

Huntington Bank-Tallmadge
505 South Ave.
Tallmadge, OH 44278

Existing Elevation

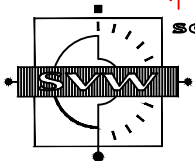
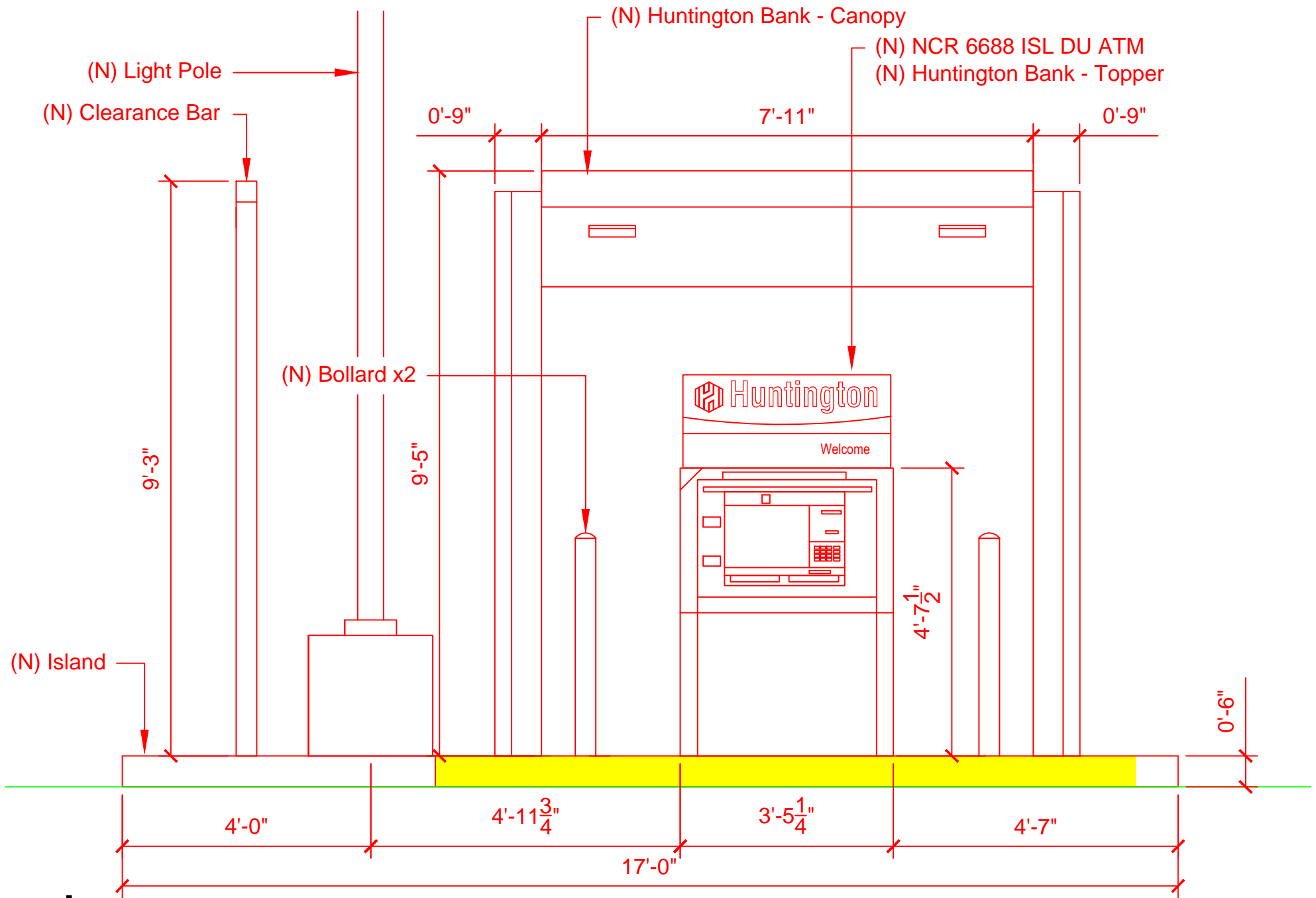

security vault works

980 Western Drive
 Indianapolis, IN 46241
 Phone 317/271.1130
 Fax 317/271.1596

Huntington Bank-Tallmadge
 505 South Ave.
 Tallmadge, OH 44278

Proposed Elevation

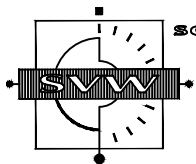

**security vault
works**

980 Western Drive
Indianapolis, IN 46241
Phone 317/271.1130
Fax 317/271.1596

Huntington Bank-Tallmadge
505 South Ave.
Tallmadge, OH 44278

Rendering