

SCALE IN FEET
MAJOR CONTOUR INTERVAL: 10'

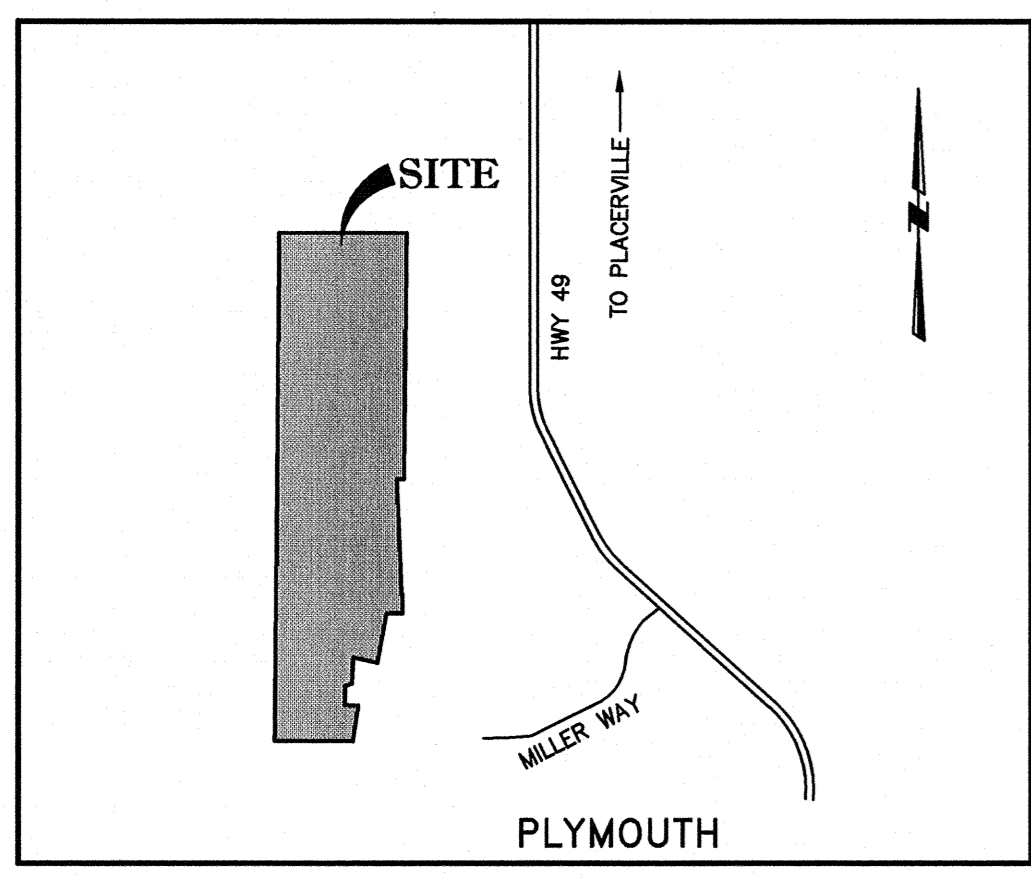

VICINITY MAP

007-090-004
Gansberg, Chris
2003R007411

TENTATIVE SUBDIVISION MAP FOR: "SHENANDOAH RIDGE"

A PLANNED DEVELOPMENT
AUGUST 2006 / REV. FEBRUARY & OCTOBER 2011
BEING A PORTION OF SECTION 3, T.7N., R.10E., M.8M
COUNTY OF AMADOR, STATE OF CALIFORNIA

- GENERAL NOTES:**
- ROADWAY MAY BE SUPER-ELEVATED IF APPROVED BY CITY ENGINEER.
 - ROADWAY MAY BE SPLIT IF APPROVED BY CITY ENGINEER. TWO FOOT SHOULDER TO BE ADDED TO INTERIOR OF ROADWAY WHEN SPLITTING ROADWAY.
 - ALL CUT/FILL SLOPES SHOWN ARE MAXIMUM SLOPES. SLOPES ARE HORIZONTAL TO VERTICAL (H/V).
 - STRUCTURAL SECTION OF ROAD TO BE DESIGNED PER CITY APPROVED STANDARDS.
 - SHOULDER SECTION TO BE DESIGNED TO THE SATISFACTION OF THE CITY.
 - PAVING TO BE ASPHALT CONCRETE PER CITY STANDARD SPECIFICATIONS.
 - JOINT TRENCH TO BE LOCATED UNDER PAVEMENT.
 - ALTERNATE B CONSTRUCTION (WITH CURB AND PAVEMENT ADJACENT TO PAVEMENT) TO BE USED ONLY AT STEEP SLOPE LOCATIONS APPROVED BY THE CITY ENGINEER TO PRESERVE NATURAL FEATURES SUCH AS PROTECTED TREES AND MAJOR ROCK OUTCROPPINGS.
 - CONCRETE CURB & GUTTER TO BE INSTALLED AT CRITICAL DRAINAGE POINTS AS REQUIRED BY THE CITY ENGINEER.


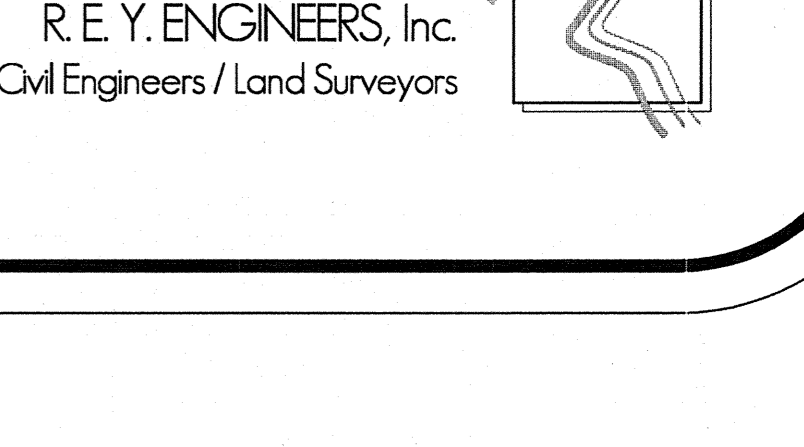
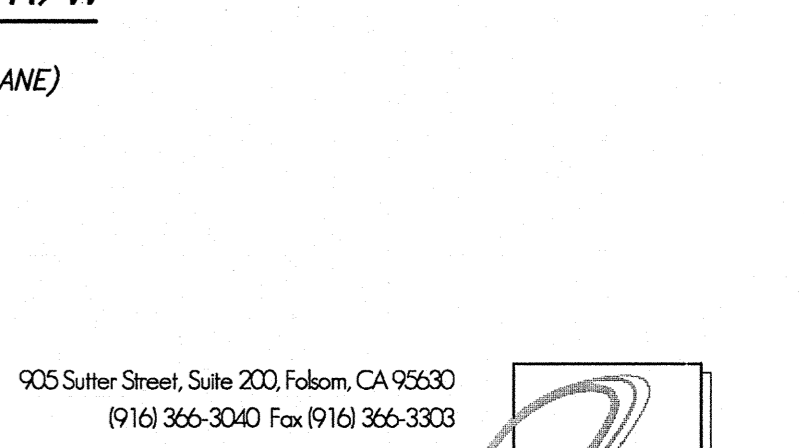
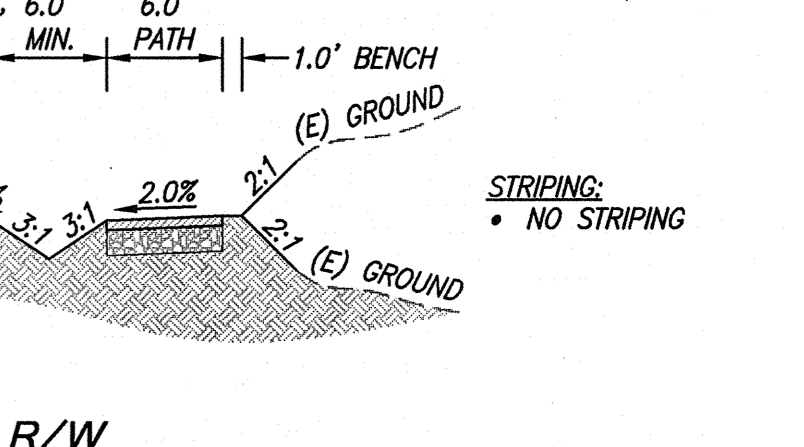
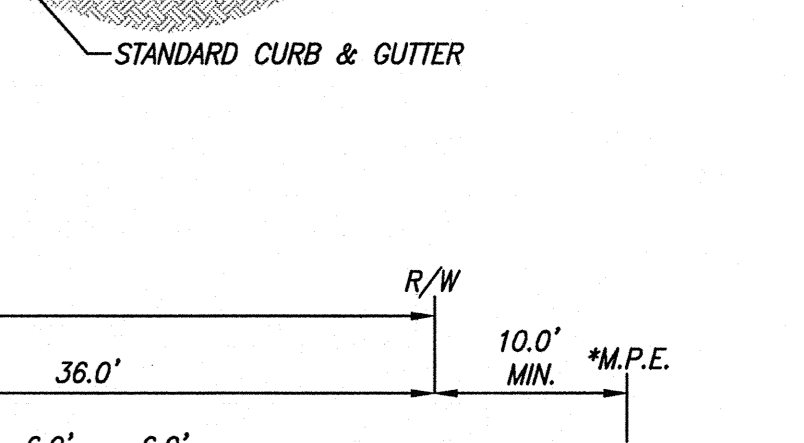
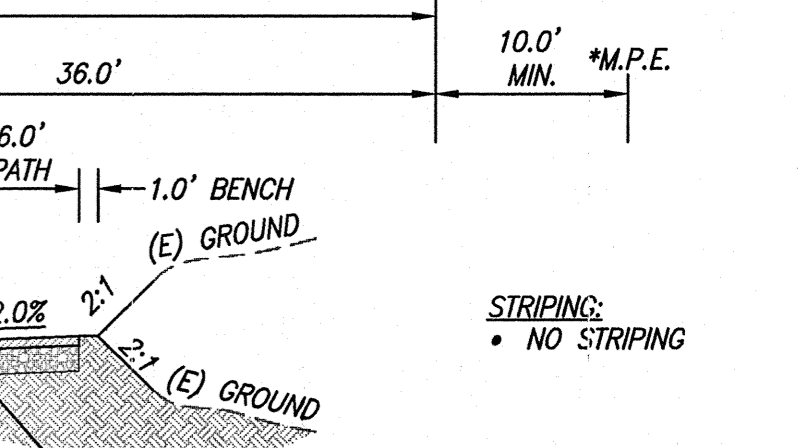
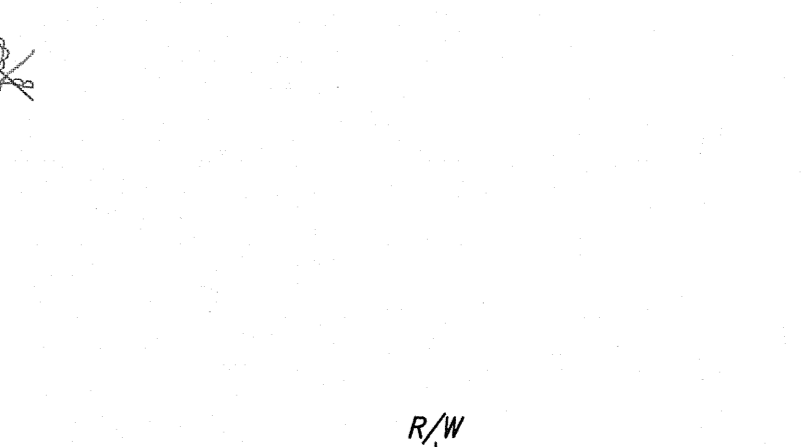
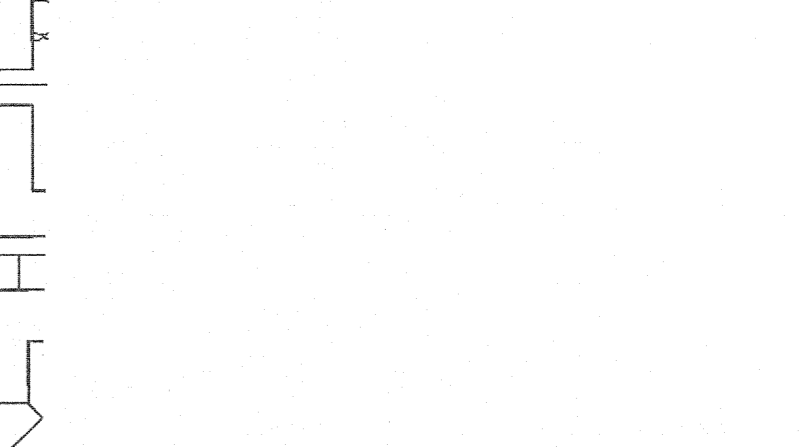
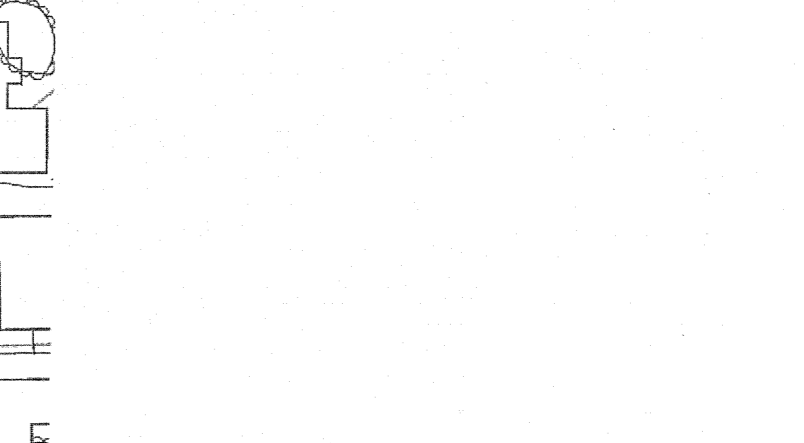
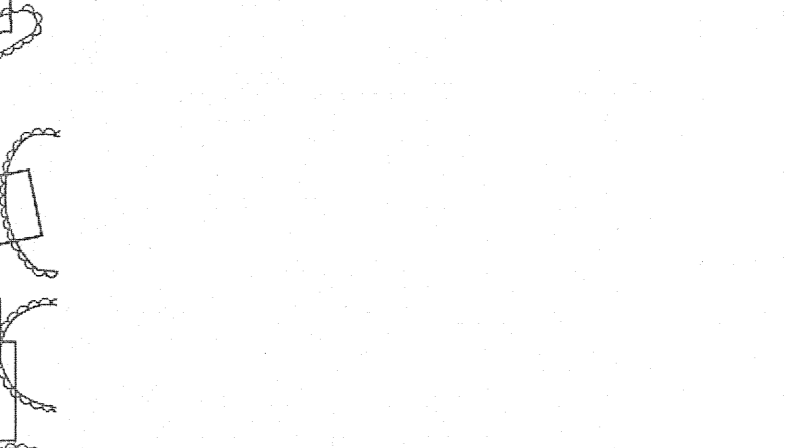
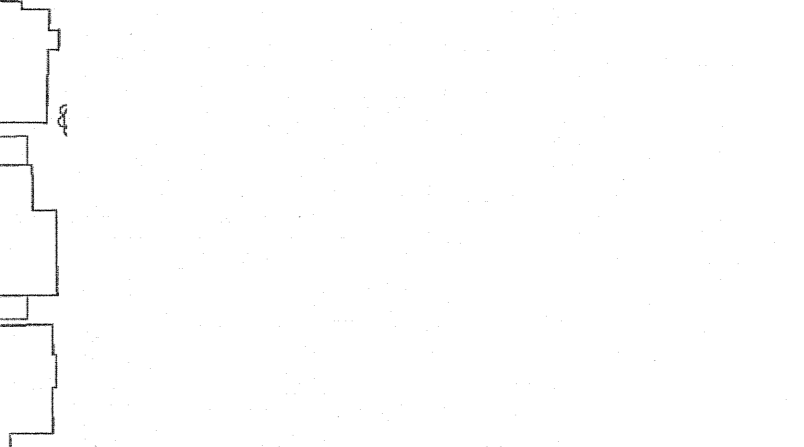
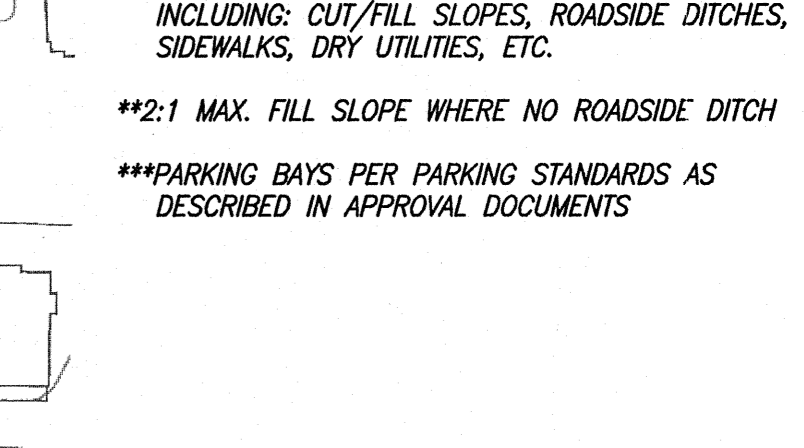
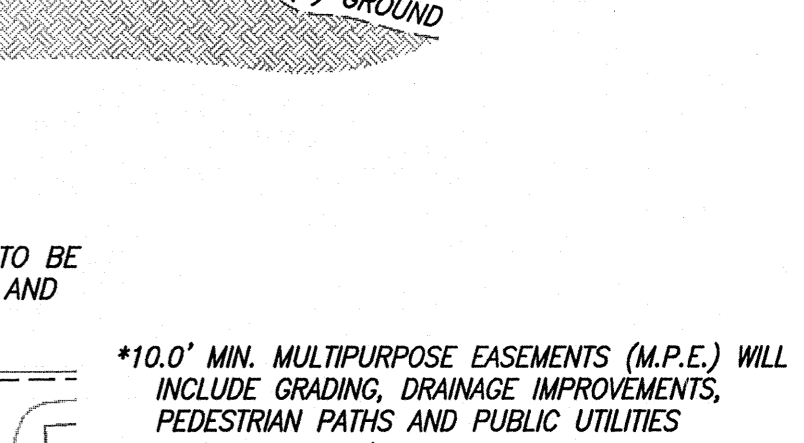
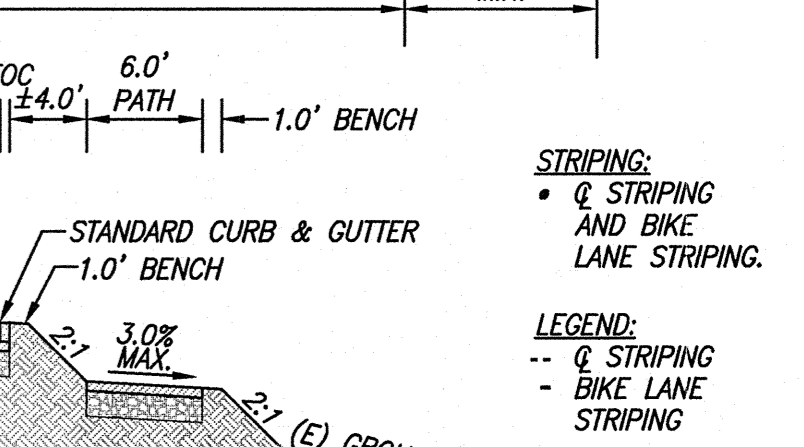
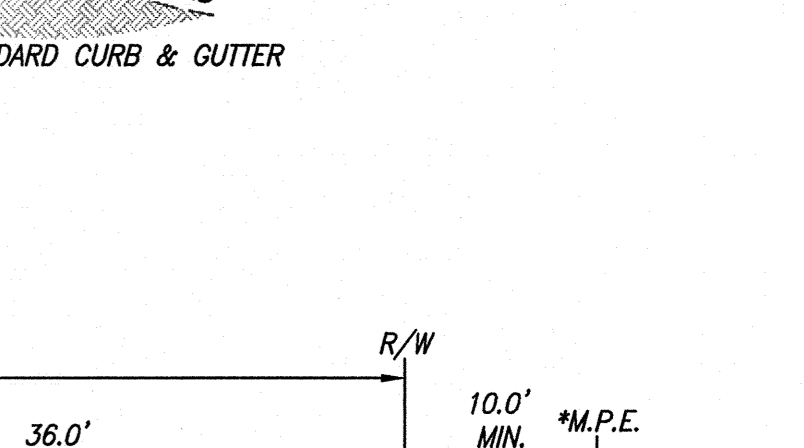
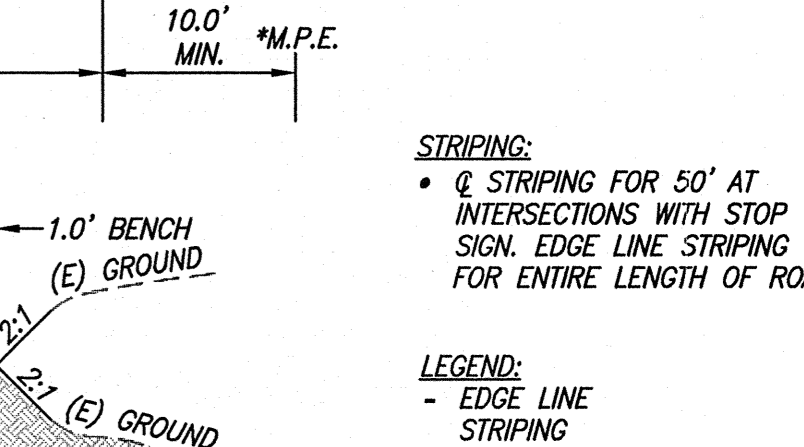
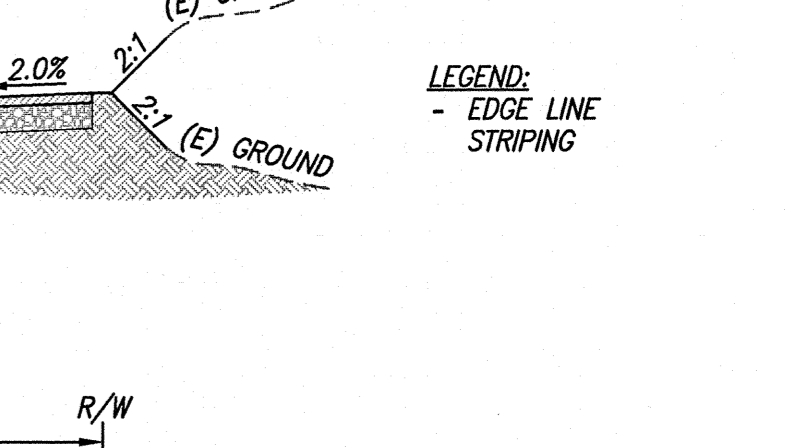
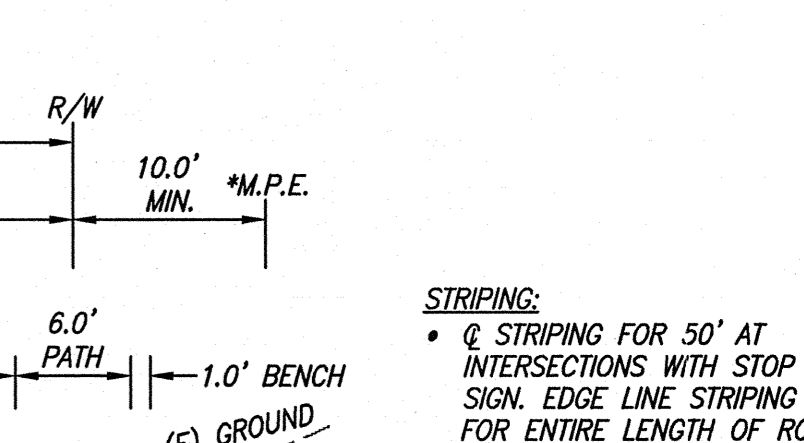
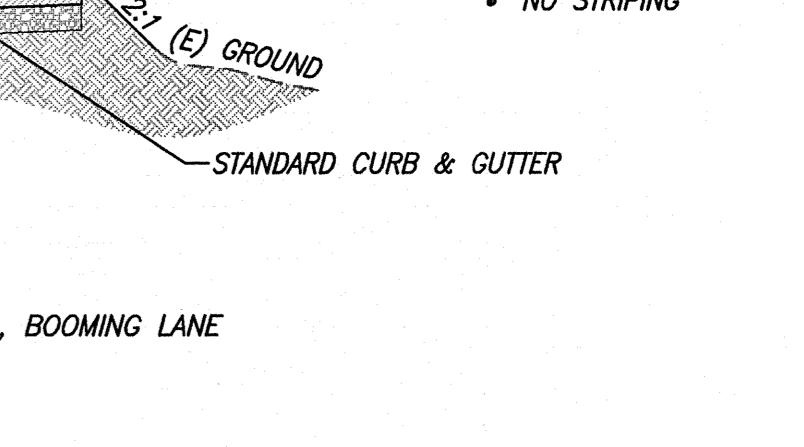
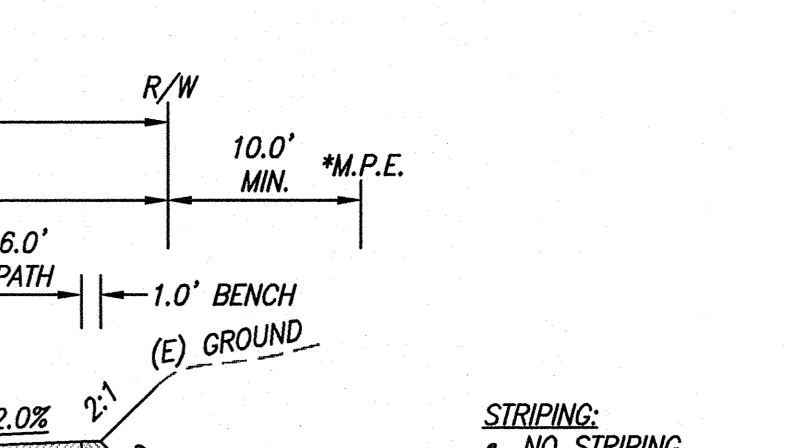
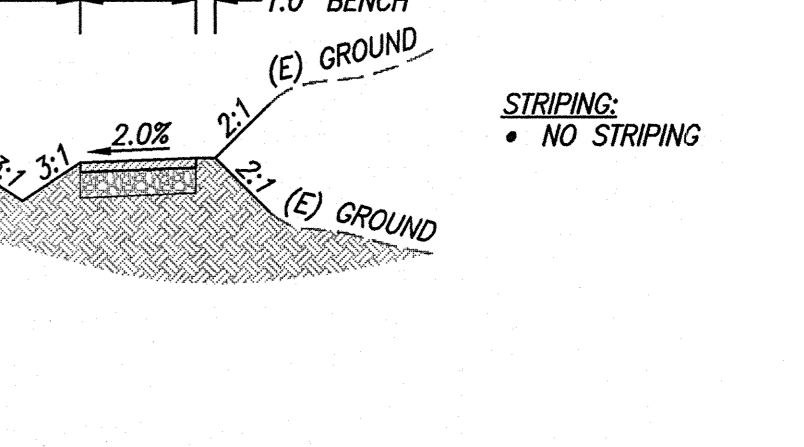
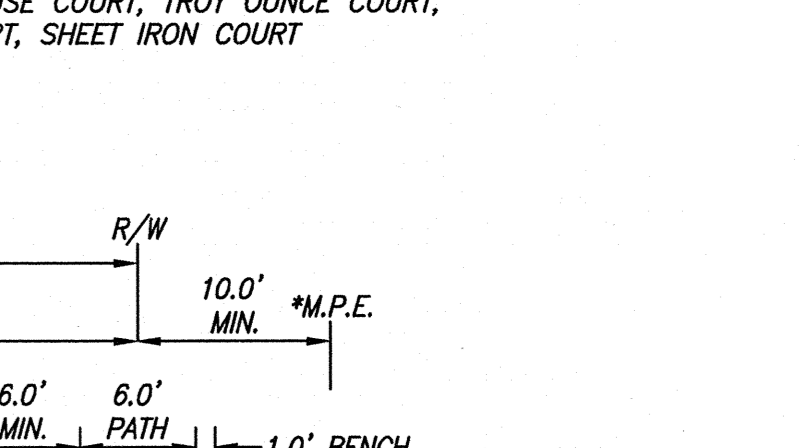
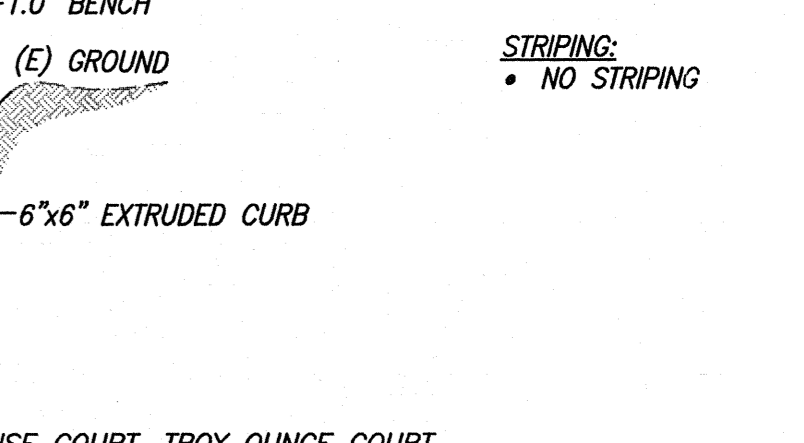
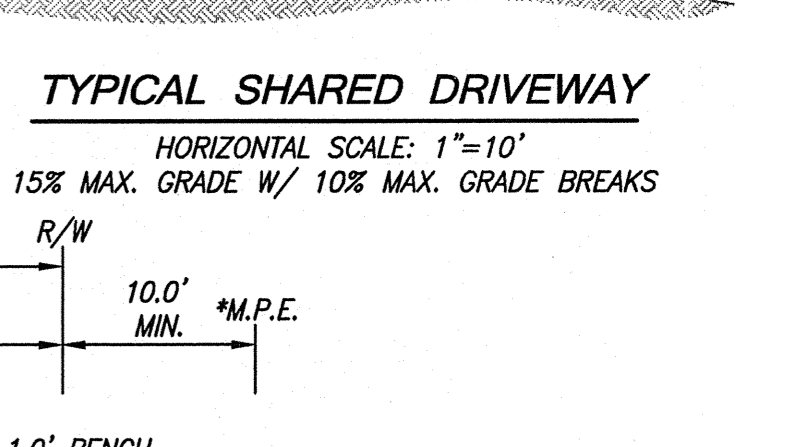
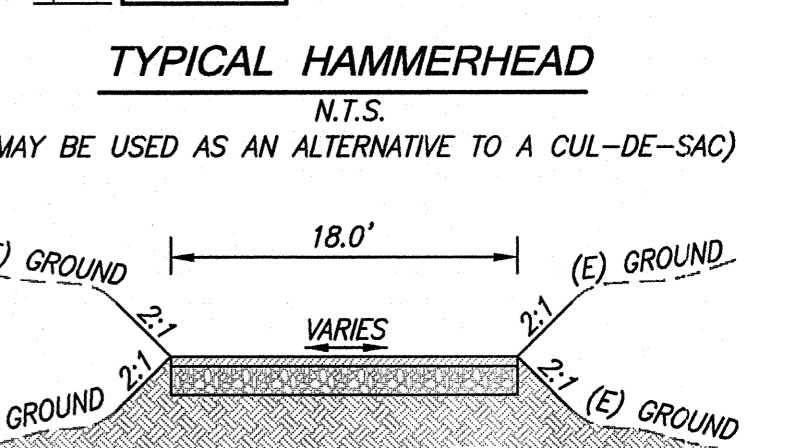
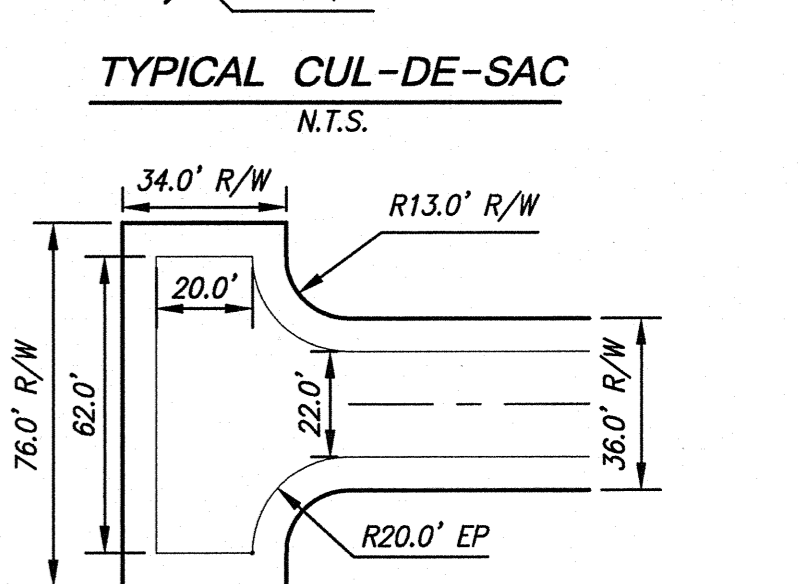
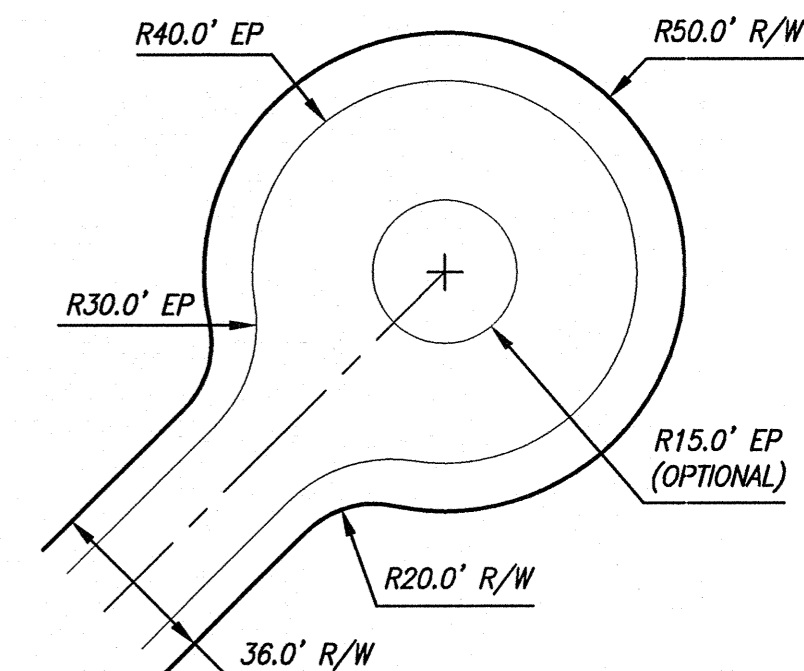

OWNER/SUBDIVIDER

SHENANDOAH RIDGE LLC
5655 RED VALLEY ROAD
DINE, CA 95645 (925) 274-4889

ENGINEER

R.E.Y. ENGINEERS, INC.
906 BUTLER STREET, SUITE 200
FOLSOM, CA 95630

ENGINEER OF WORK

R.E.Y. ENGINEERS, INC.

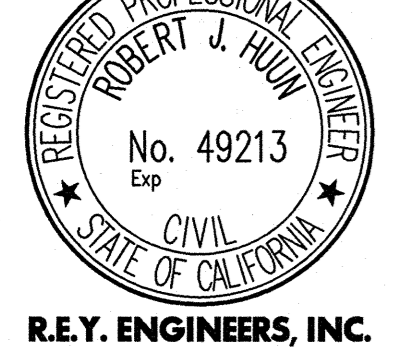

MAP SCALE

1"=100'

SECTION TOWNSHIP & RANGE

FOR SECTION 3, T.7N., R.10E., M.8M

EXISTING/PROPOSED ZONING

EXISTING - R1A
PROPOSED - PD-PLANNED DEVELOPMENT (WEST) & OS-OPEN SPACE

DEED REFERENCE NO.

2007-006322

ASSESSOR'S PARCEL NUMBER

029-028-022

GENERAL PLAN

AMADOR COUNTY AG
CITY OF PLYMOUTH SUBURBAN RESIDENTIAL

PROPERTY SIZE

147.7 ACRES DIVIDED AS SHOWN ON PLANS
137 TOTAL LOTS
PROPOSED DEVELOPMENT - SINGLE FAMILY
(A) 324 ACRES OPEN SPACE & PARKS
(B) 115 ACRES RESIDENTIAL LOTS & STREETS

FIRE PROTECTION

CITY OF PLYMOUTH

LAND USE

PROPOSED - SINGLE FAMILY RESIDENTIAL
EXISTING - CURRENTLY NOT USED FOR ANY PURPOSE / CATTLE GRAZING

UTILITIES

GAS - CENTRALIZED PROPANE (UNDER CITY FRANCHISE)
POWER - P.G. & E.
WATER - CITY OF PLYMOUTH
SEWER - CITY OF PLYMOUTH
TELEPHONE - AT&T
CABLE TV - COMCAST

EASEMENTS

EASEMENTS FOR PUBLIC UTILITIES WILL BE PROVIDED AS NEEDED. EXISTING EASEMENTS AS SHOWN ON TITLE REPORT FROM PLACER TITLE COMPANY ORDER # 90-979. PRIVATE DRAINAGE EASEMENTS WILL BE 20' ALONG ALL NATURAL AND/OR NEWLY REVISED DRAINAGE COURSES AS DETERMINED BY THE IMPROVEMENT PLANS.

PHASING PLAN NOTICE

FINAL MAPS MAY BE SUBMITTED IN MULTIPLE PHASINGS.

SCHOOL DISTRICT

AMADOR COUNTY UNIFIED SCHOOL DISTRICT

FLOOD ZONE

THIS PROJECT IS NOT WITHIN ANY AREA SUBJECT TO FLOOD WATER INUNDATION AND IS WITHIN ZONE "X" AS SHOWN ON THE FLOOD INSURANCE RATE MAP FOR AMADOR COUNTY MAP NO. 900555008P (DATED MAY 20, 2010).

STATEMENTS

A. THE DEVELOPER PLANS TO CONSTRUCT ALL IMPROVEMENTS REQUIRED FOR THE CREATION OF LOTS AND FILING OF FINAL MAPS AS REQUIRED BY ALL APPLICABLE CITY CODES AND THE CONDITIONS OF APPROVAL OF THE TENTATIVE MAP.

B. DEVELOPER MAY EITHER DEVELOP AND OFFER FOR SALE FINISHED LOTS OR BUILD OUT HOMES.

C. COAR'S WILL RESTRICT ANY FURTHER DIVISIONS OF LOTS.

D. LOT A IS FOR CENTRALIZED PROPANE TANK.

E. LOT P1 IS A NEIGHBORHOOD PARK.

F. PROPERTY IS SUBJECT TO THE PUBLIC UTILITY AND INGRESS EGRESS EASEMENTS AS DESCRIBED IN DOC. # 90-9009-000762 AND 2006-000763 (RELOCATABLE).

OWNER'S STATEMENT

I AM THE AGENT OF OWNER OF RECORD AND CONSENT TO THE FILING OF THIS TENTATIVE MAP IN COMPLIANCE WITH THE REQUIREMENTS OF TITLE 16 OF THE PLYMOUTH MUNICIPAL CODE AND TITLE 7, DIVISION 2 OF THE CALIFORNIA GOVERNMENT CODE THE SUBDIVISION MAP ACT.

SHENANDOAH RIDGE LLC
BY: *Bob Reeder* 10/21/11
BOB REEDER, PRESIDENT DATE
REEDER SUTHERLAND INC., MANAGER

APPROVAL DATE: Oct. 27, 2011
RESOLUTION NO.: 2011-17

BY: *Jay Ballwin*
TITLE: Mayor

NOTE:

1. LOTS 36, 70, 80, 82, 83, & 93 HAVE AN OPEN SPACE EASEMENT THAT INCLUDES A PUBLIC PATH. FRONT SETBACKS ARE MEASURED FROM THE EDGE OF THE OPEN SPACE EASEMENT.

LEGEND:

○ TREE COVER
|||| NO VEHICULAR ACCESS

GENERAL NOTES:

- ROADWAY MAY BE SUPER-ELEVATED IF APPROVED BY CITY ENGINEER.
- ROADWAY MAY BE SPLIT IF APPROVED BY CITY ENGINEER. TWO FOOT SHOULDER TO BE ADDED TO INTERIOR OF ROADWAY WHEN SPLITTING ROADWAY.
- ALL CUT/FILL SLOPES SHOWN ARE MAXIMUM SLOPES. SLOPES ARE HORIZONTAL TO VERTICAL (H/V).
- STRUCTURAL SECTION OF ROAD TO BE DESIGNED PER CITY APPROVED STANDARDS.
- SHOULDER SECTION TO BE DESIGNED TO THE SATISFACTION OF THE CITY.
- PAVING TO BE ASPHALT CONCRETE PER CITY STANDARD SPECIFICATIONS.
- JOINT TRENCH TO BE LOCATED UNDER PAVEMENT.
- ALTERNATE B CONSTRUCTION (WITH CURB AND PAVEMENT ADJACENT TO PAVEMENT) TO BE USED ONLY AT STEEP SLOPE LOCATIONS APPROVED BY THE CITY ENGINEER TO PRESERVE NATURAL FEATURES SUCH AS PROTECTED TREES AND MAJOR ROCK OUTCROPPINGS.
- CONCRETE CURB & GUTTER TO BE INSTALLED AT CRITICAL DRAINAGE POINTS AS REQUIRED BY THE CITY ENGINEER.

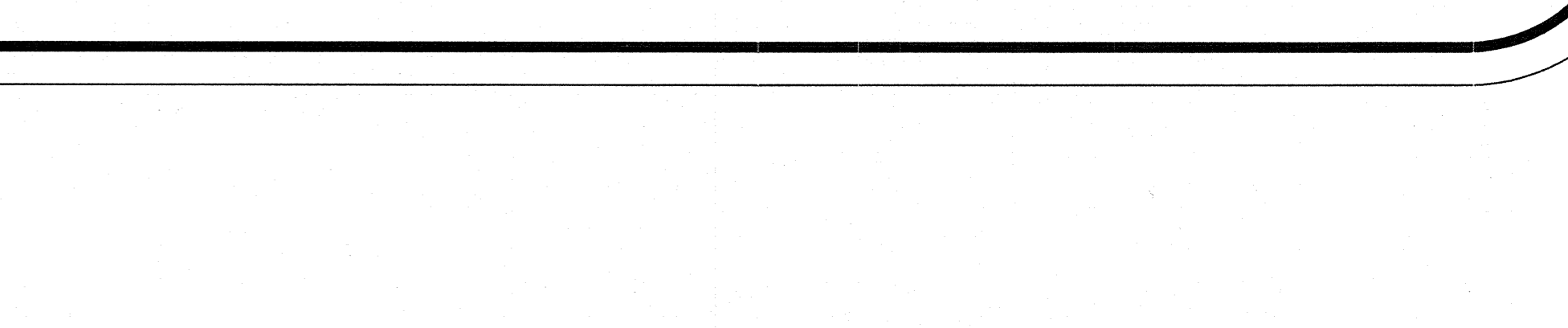
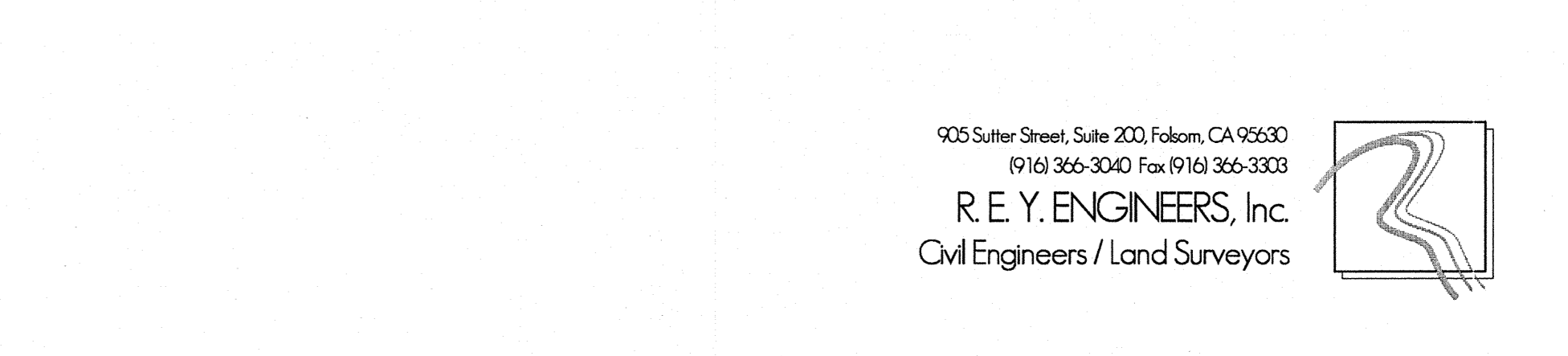
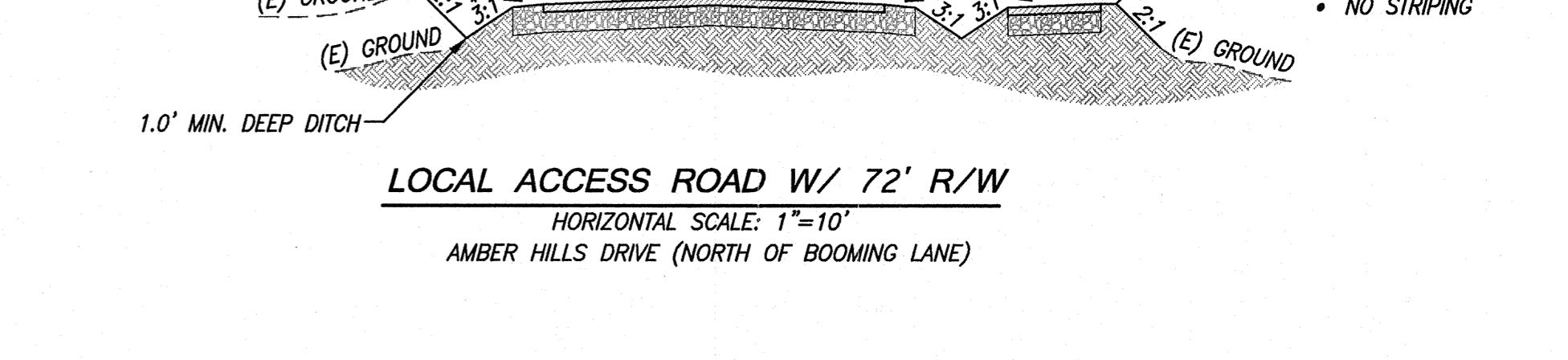
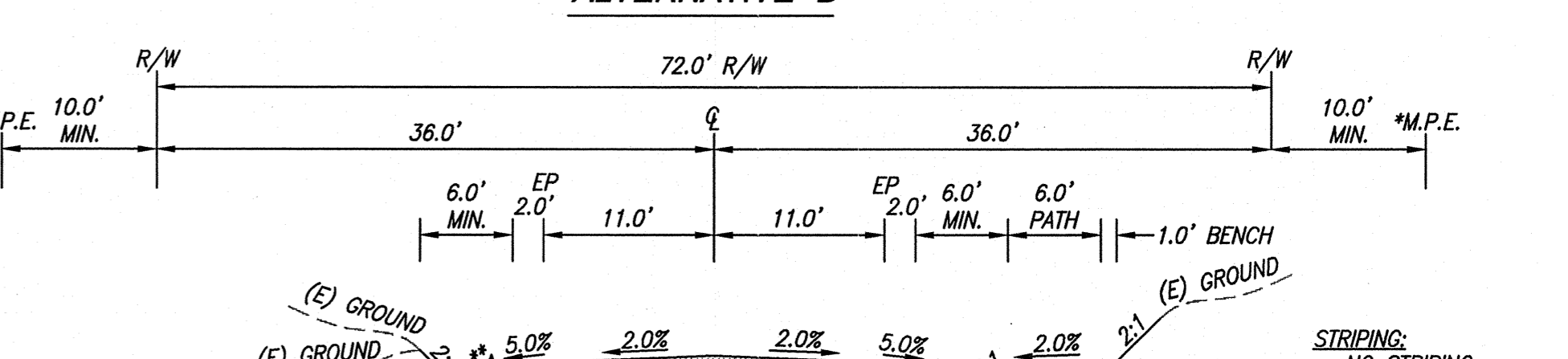
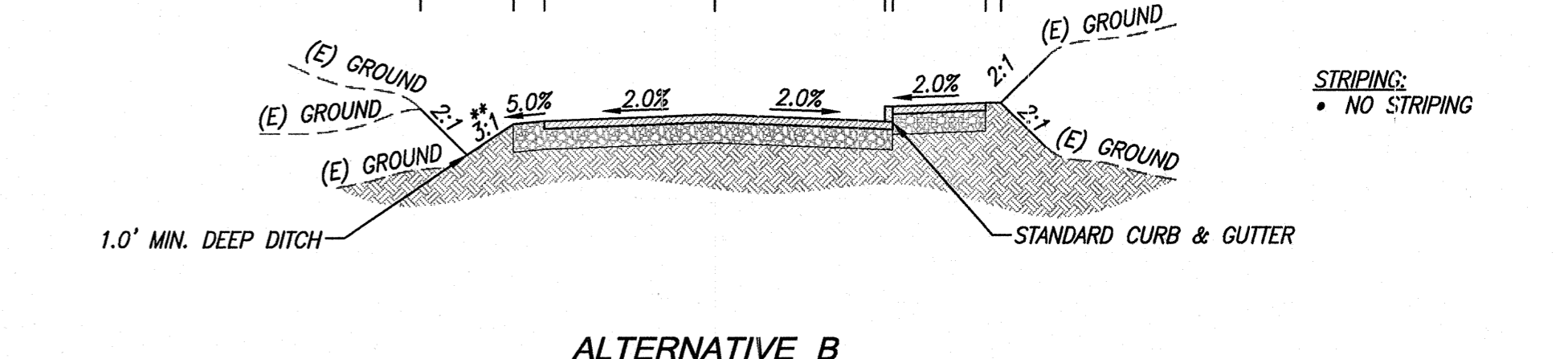
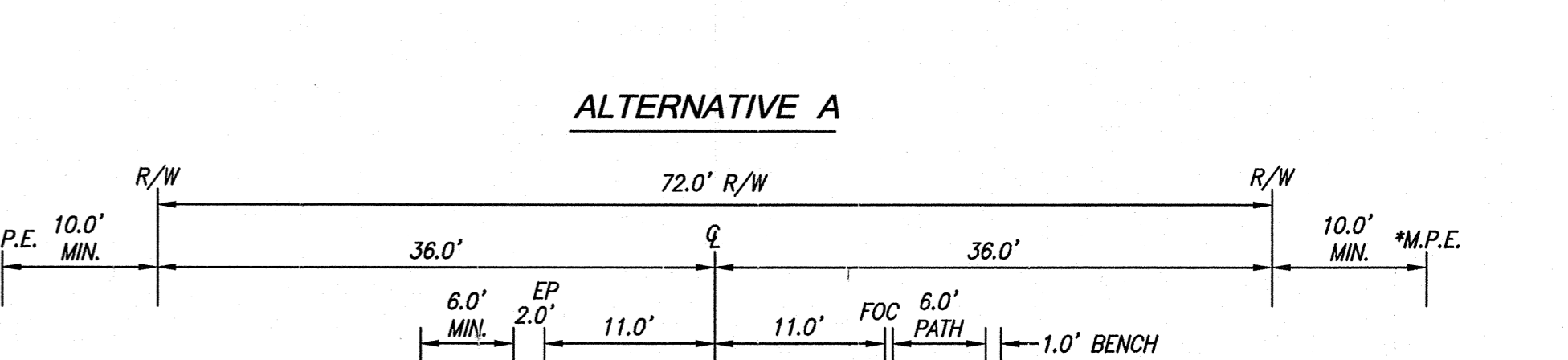
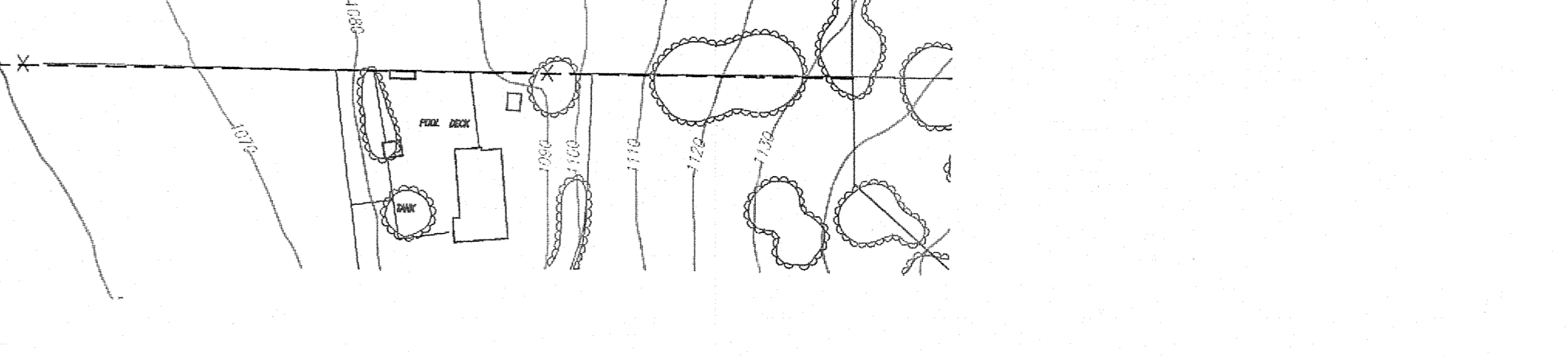
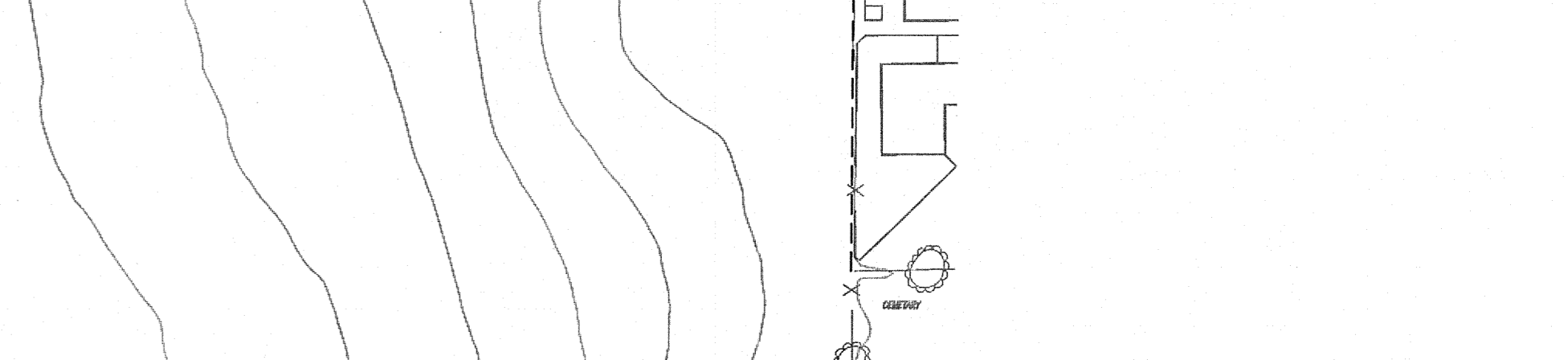
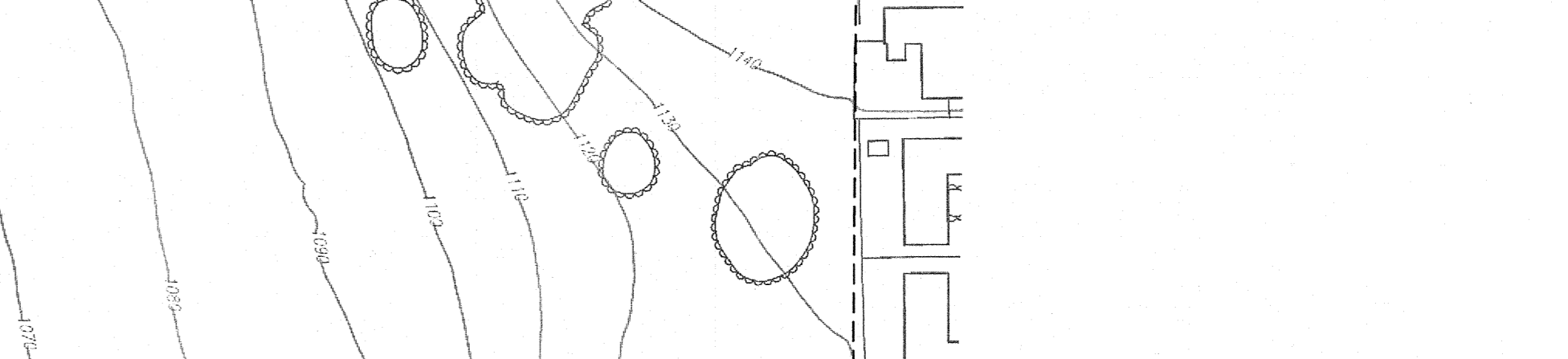
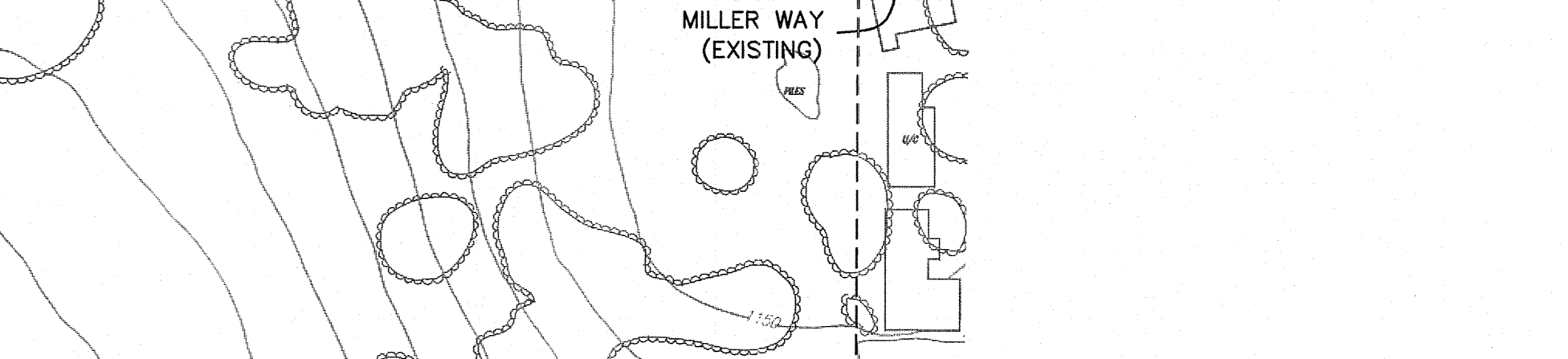
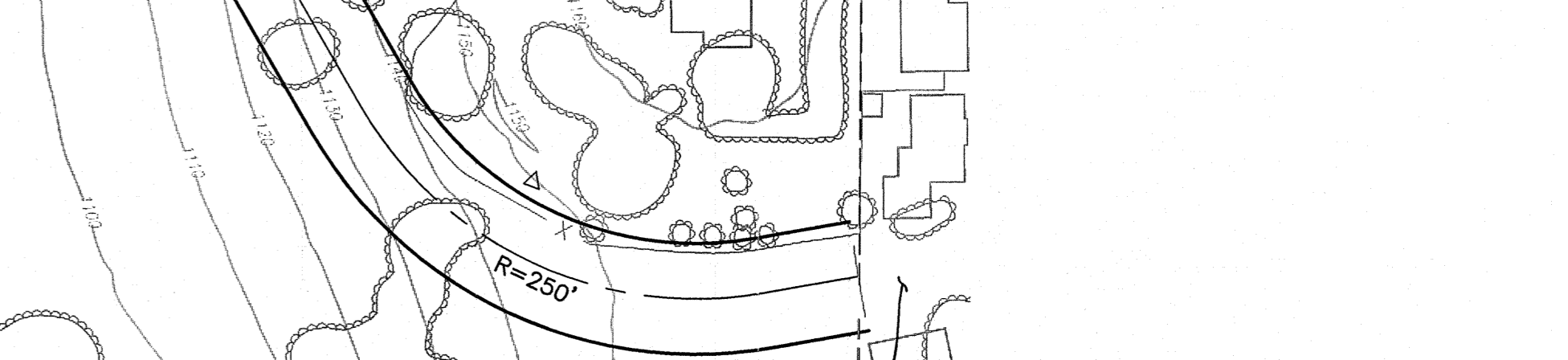
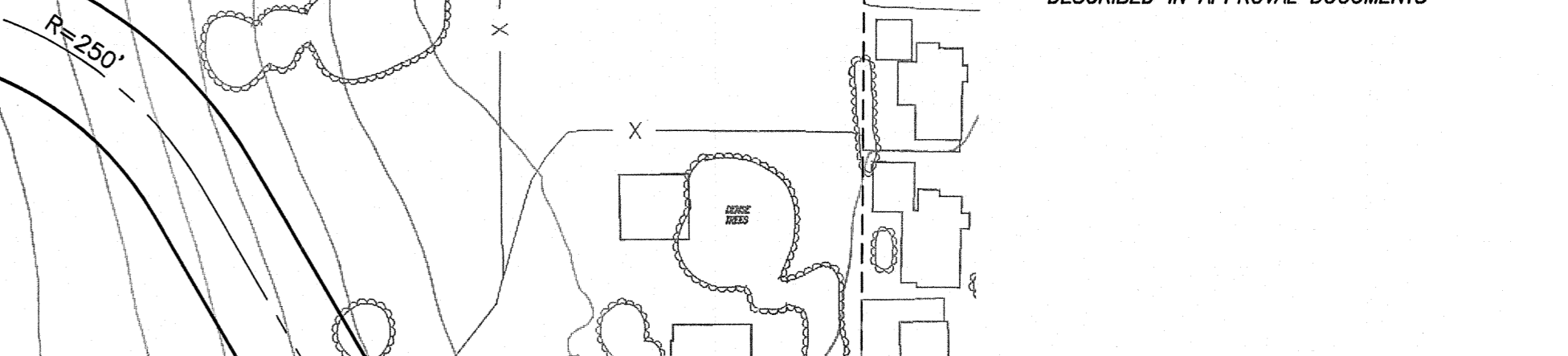
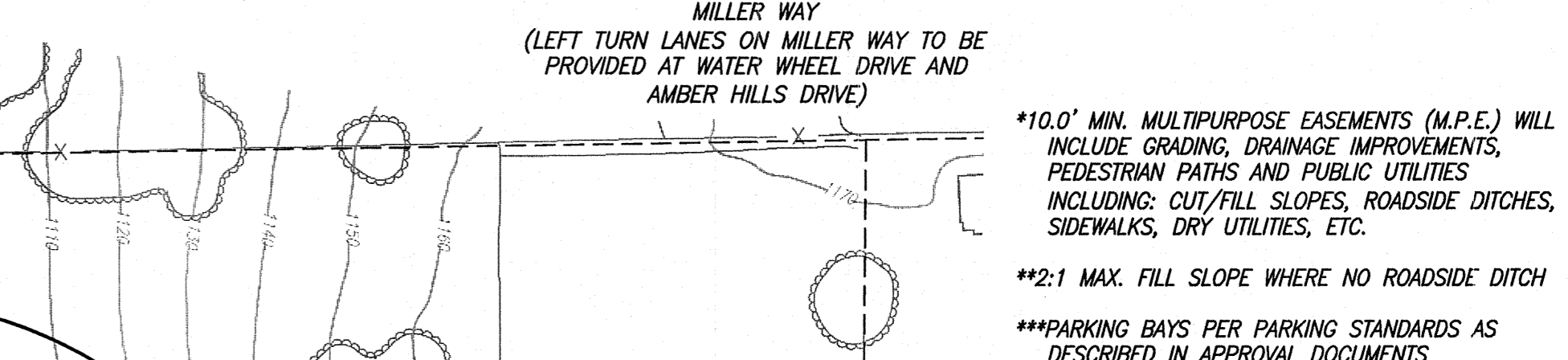
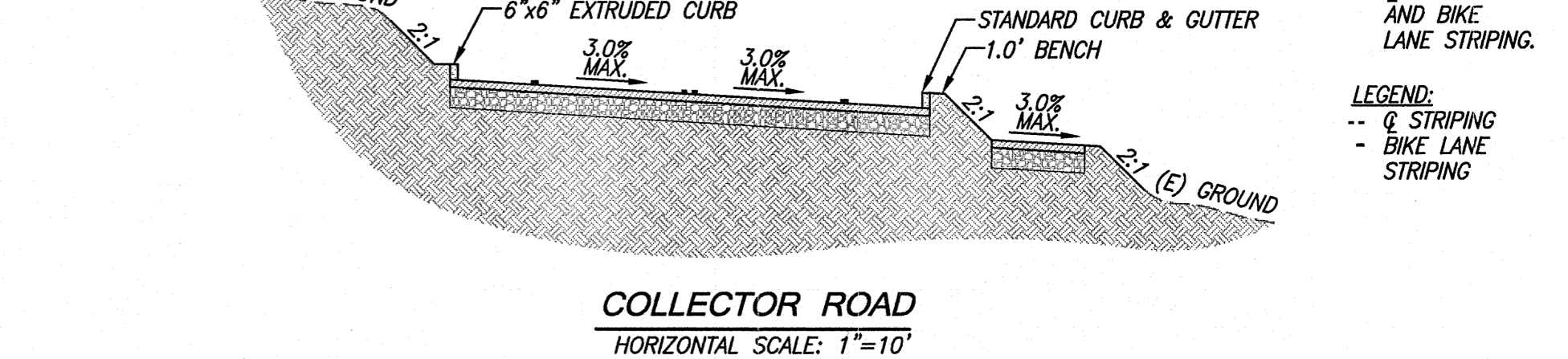
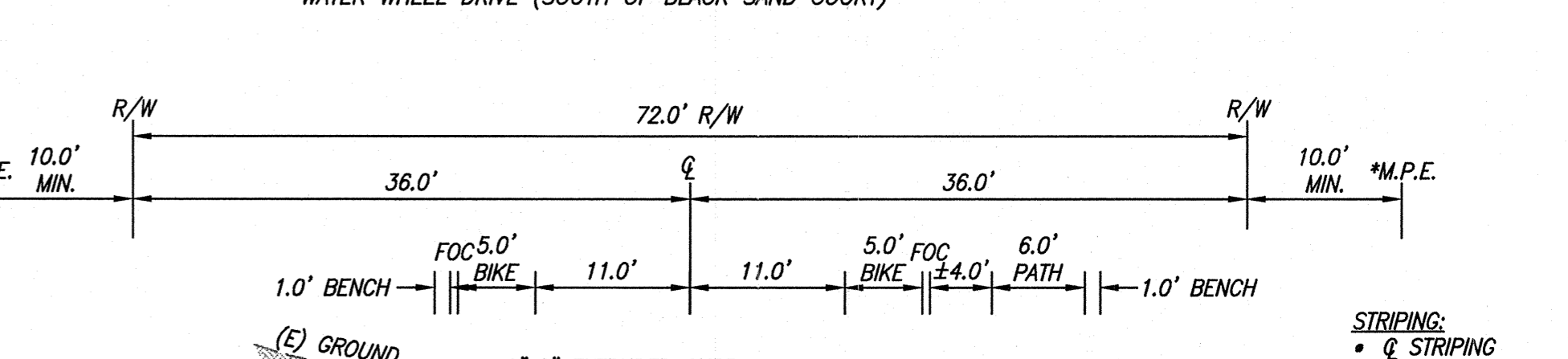
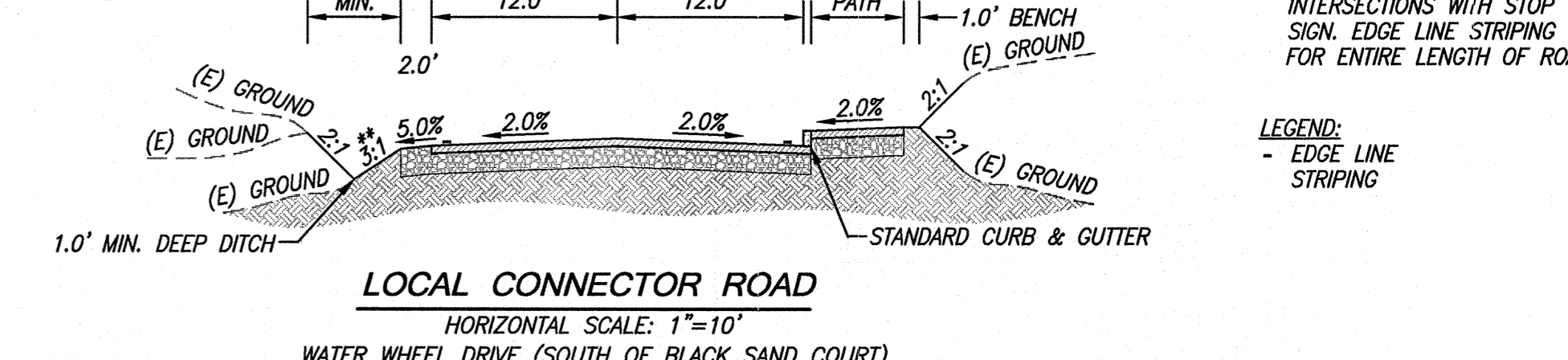
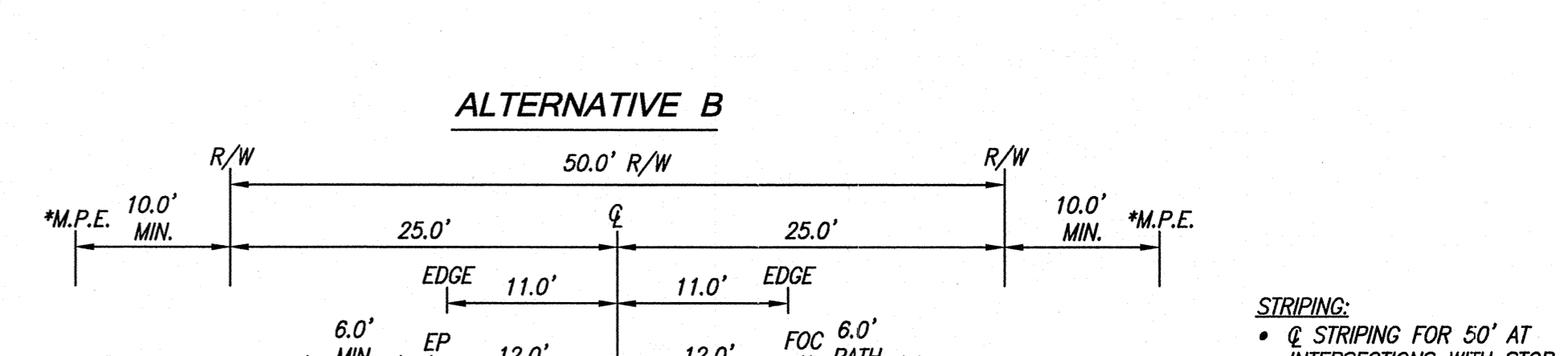
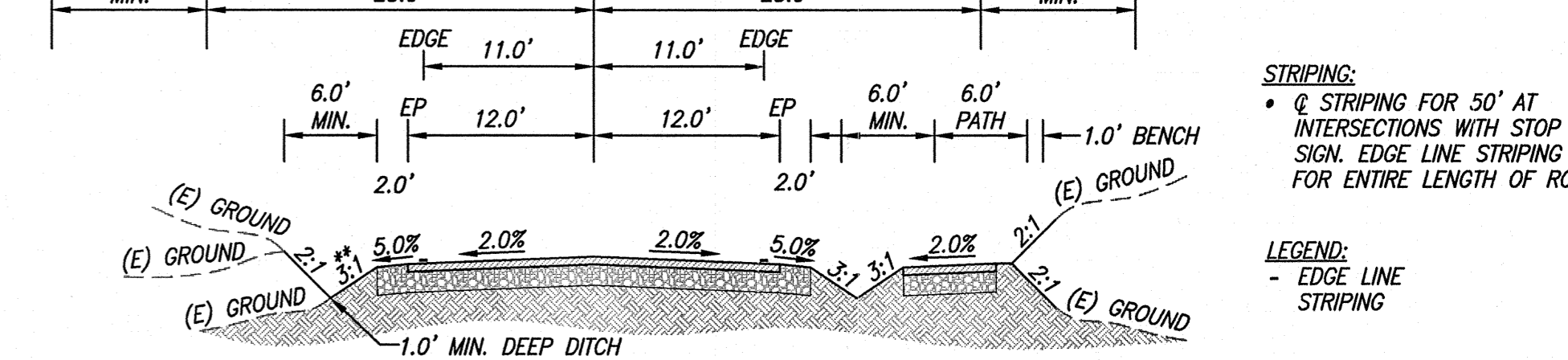
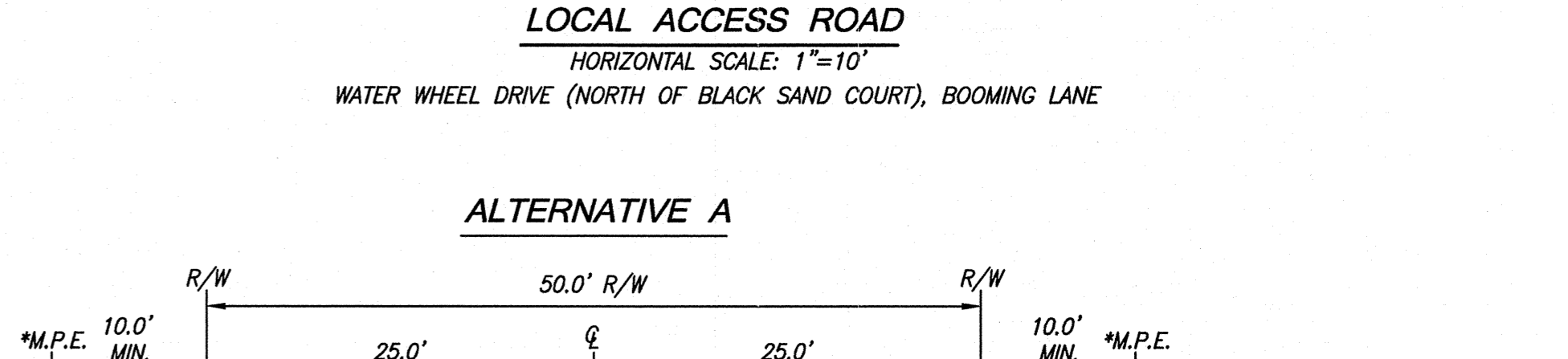
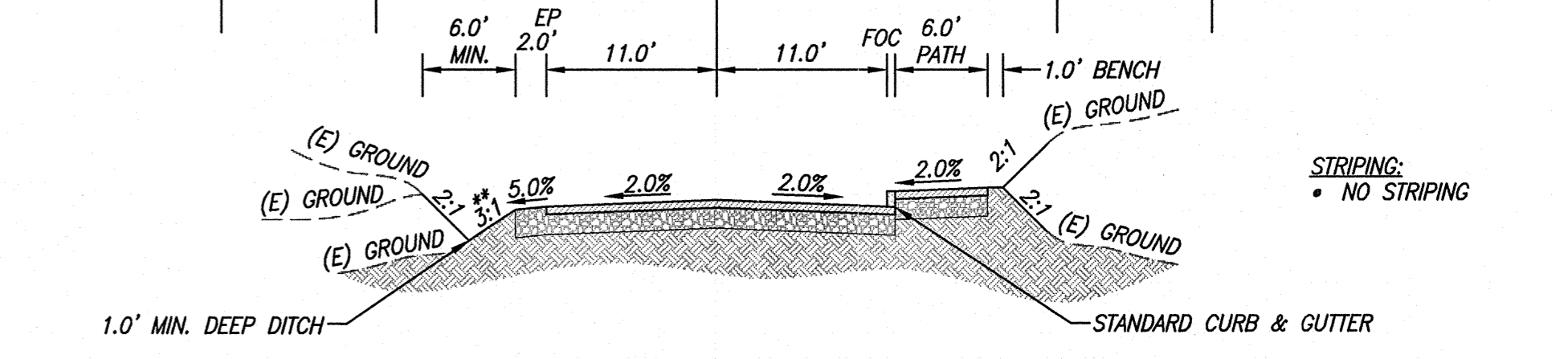
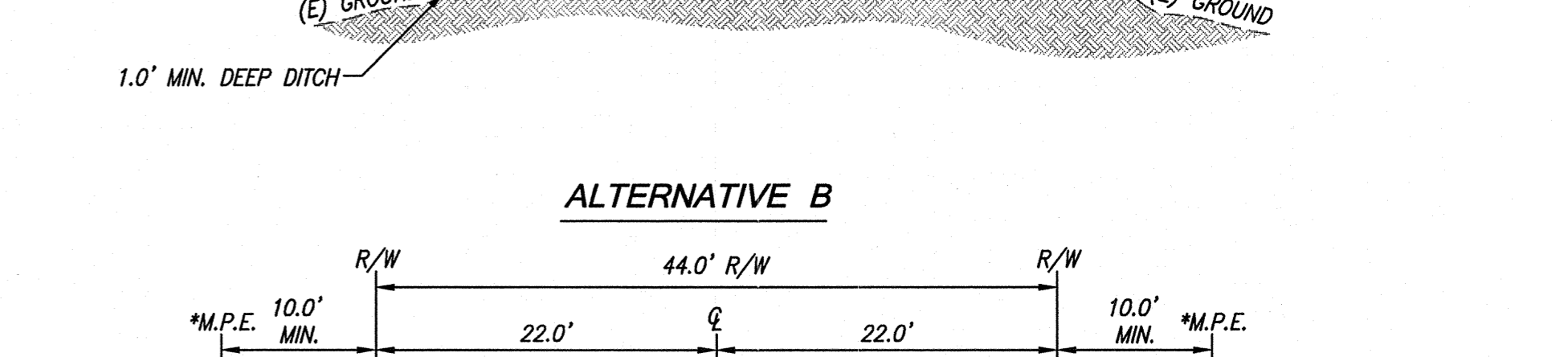
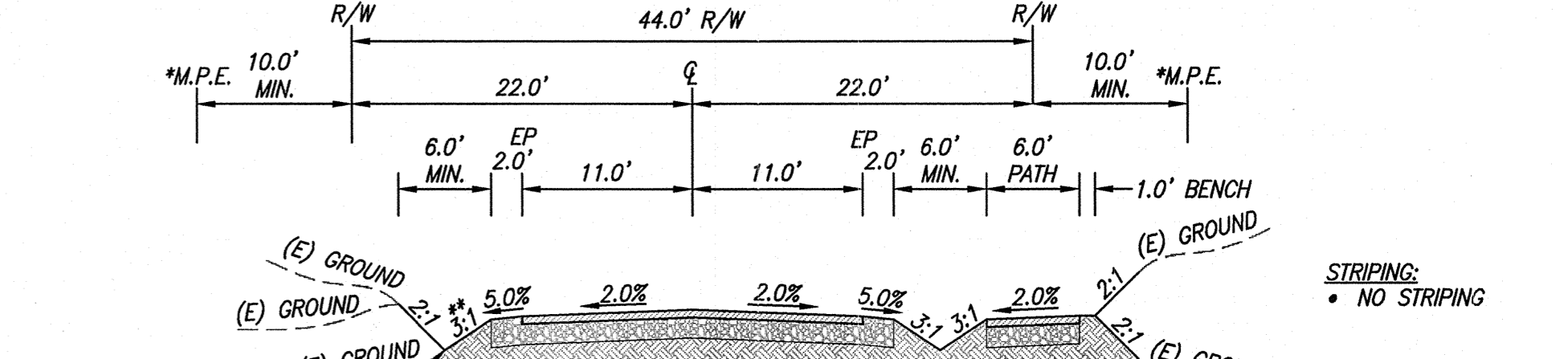
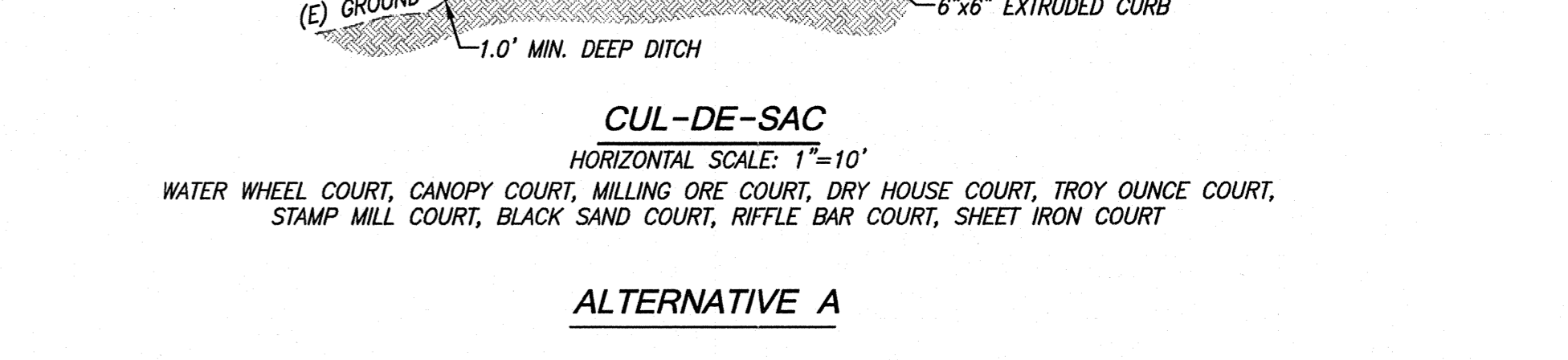
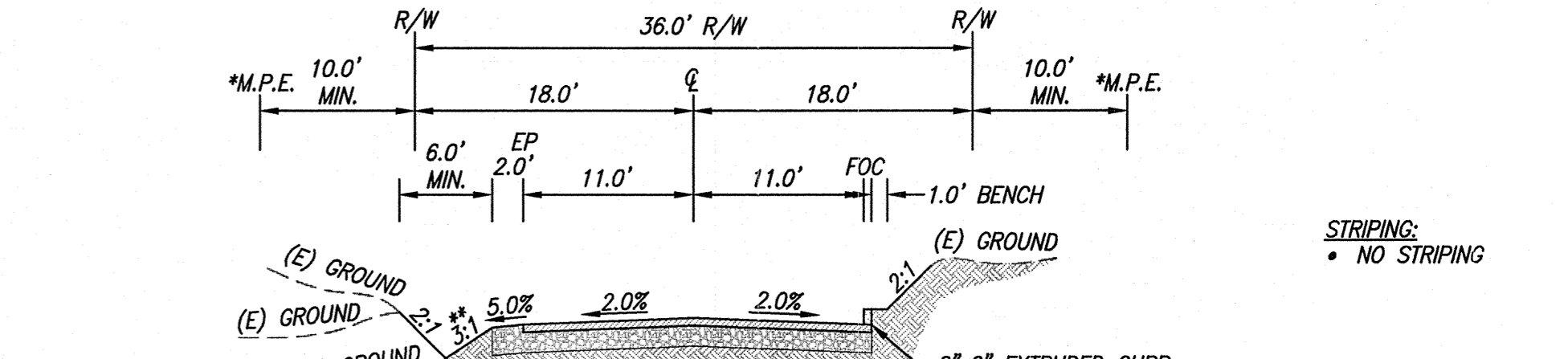
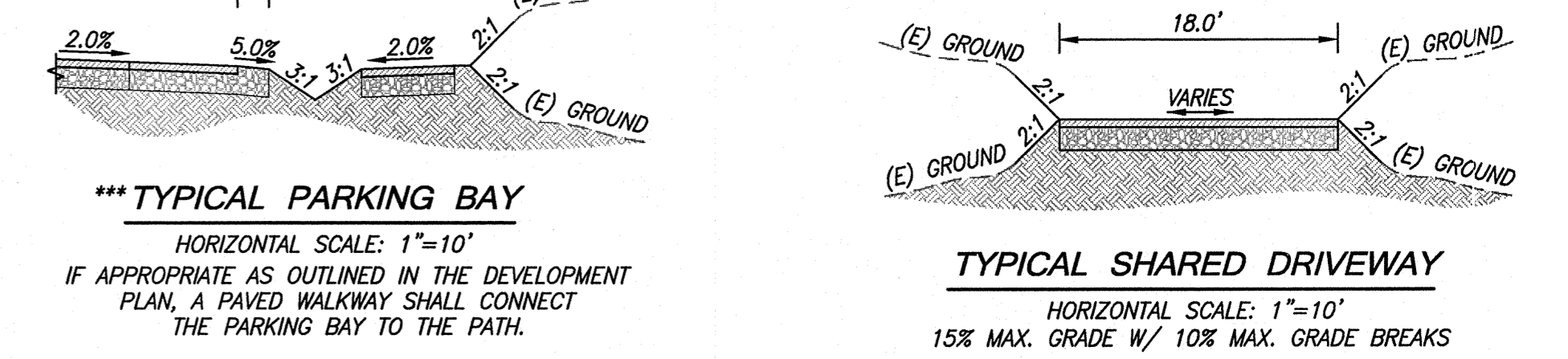
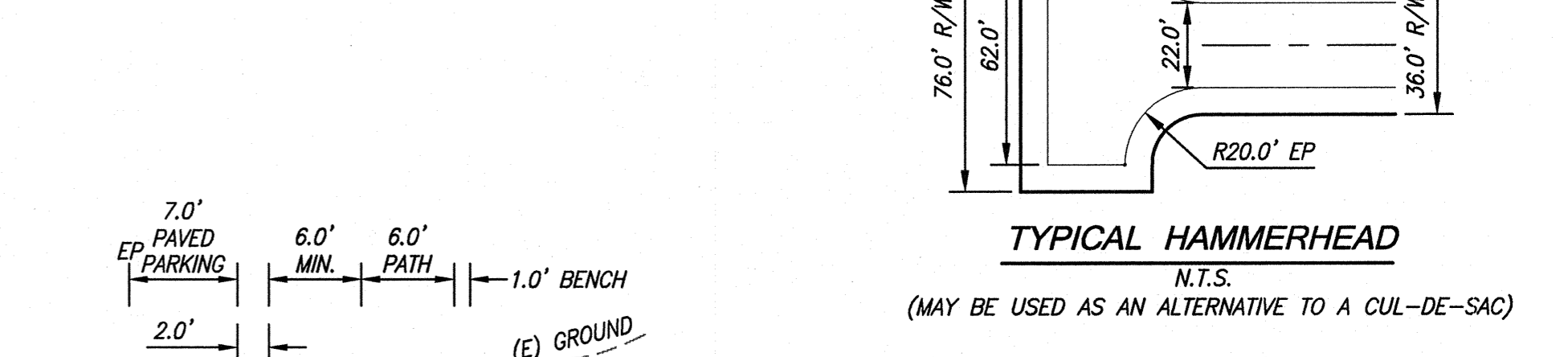

105 Shaw Street, Suite 203, Colton, CA 95320
(916) 366-3434 / (916) 366-3333

R.E.Y. ENGINEERS, Inc.

Civil Engineers / Land Surveyors

