

FLOOR PLAN

Unit 728 - #1

3,800 SF

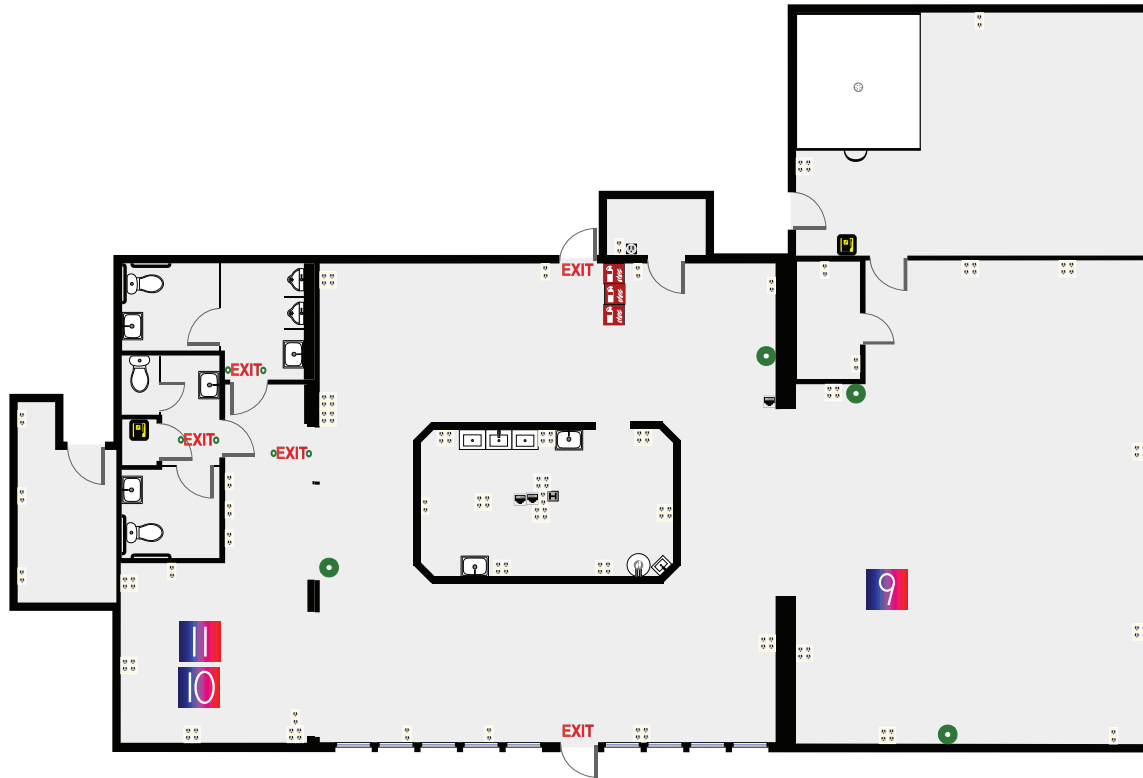

Alex Aydelotte
Partner
T: 772.223.3646
E: alex@florida-commercial.net



151,246 SF
Stuart, FL

FLOOR PLAN

Unit 742 - #8

3,200 SF

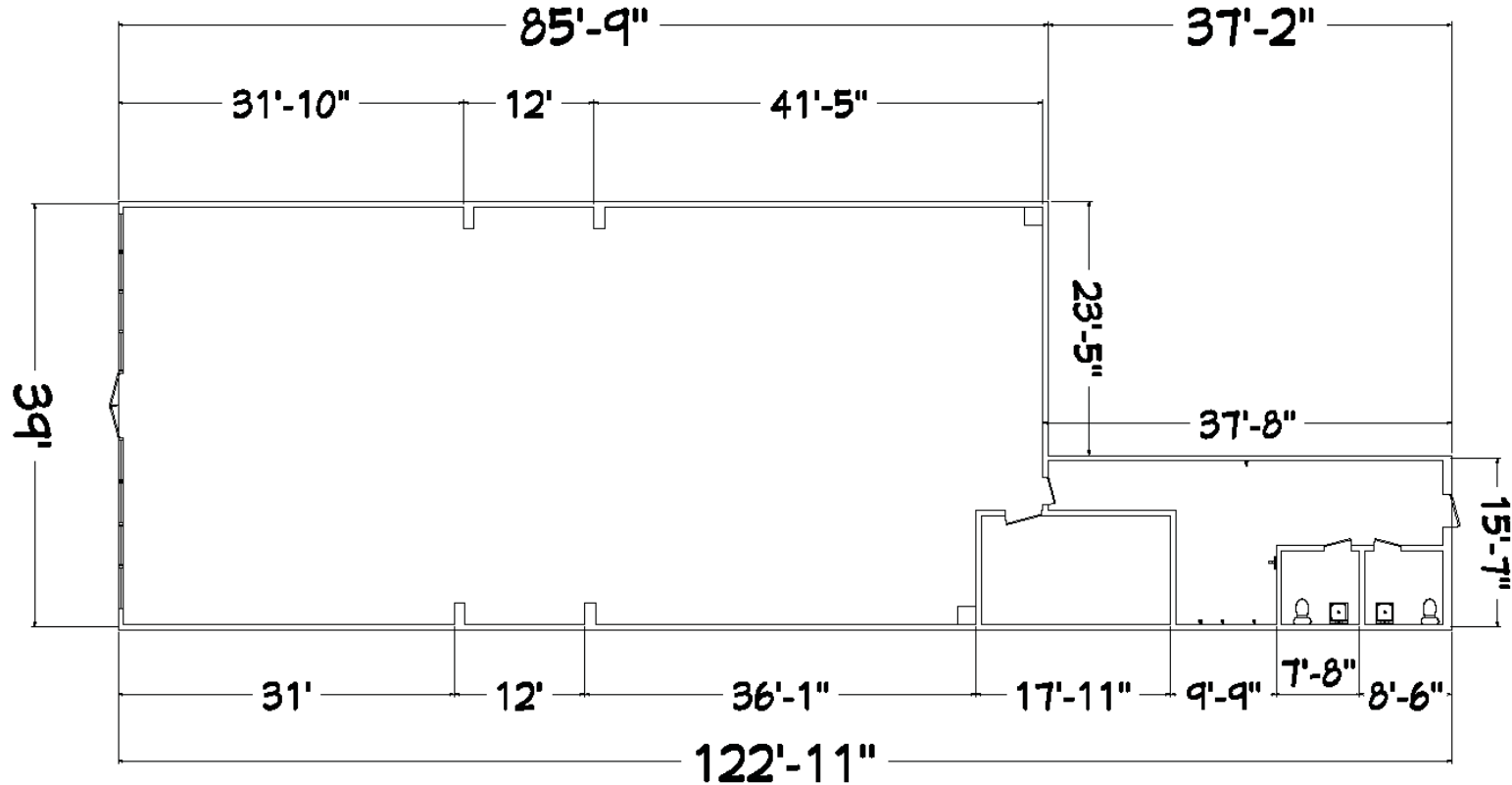

Alex Aydelotte
Partner
T: 772.223.3646
E: alex@florida-commercial.net



151,246 SF
Stuart, FL

FLOOR PLAN

Unit 790 - #13

1,800 SF

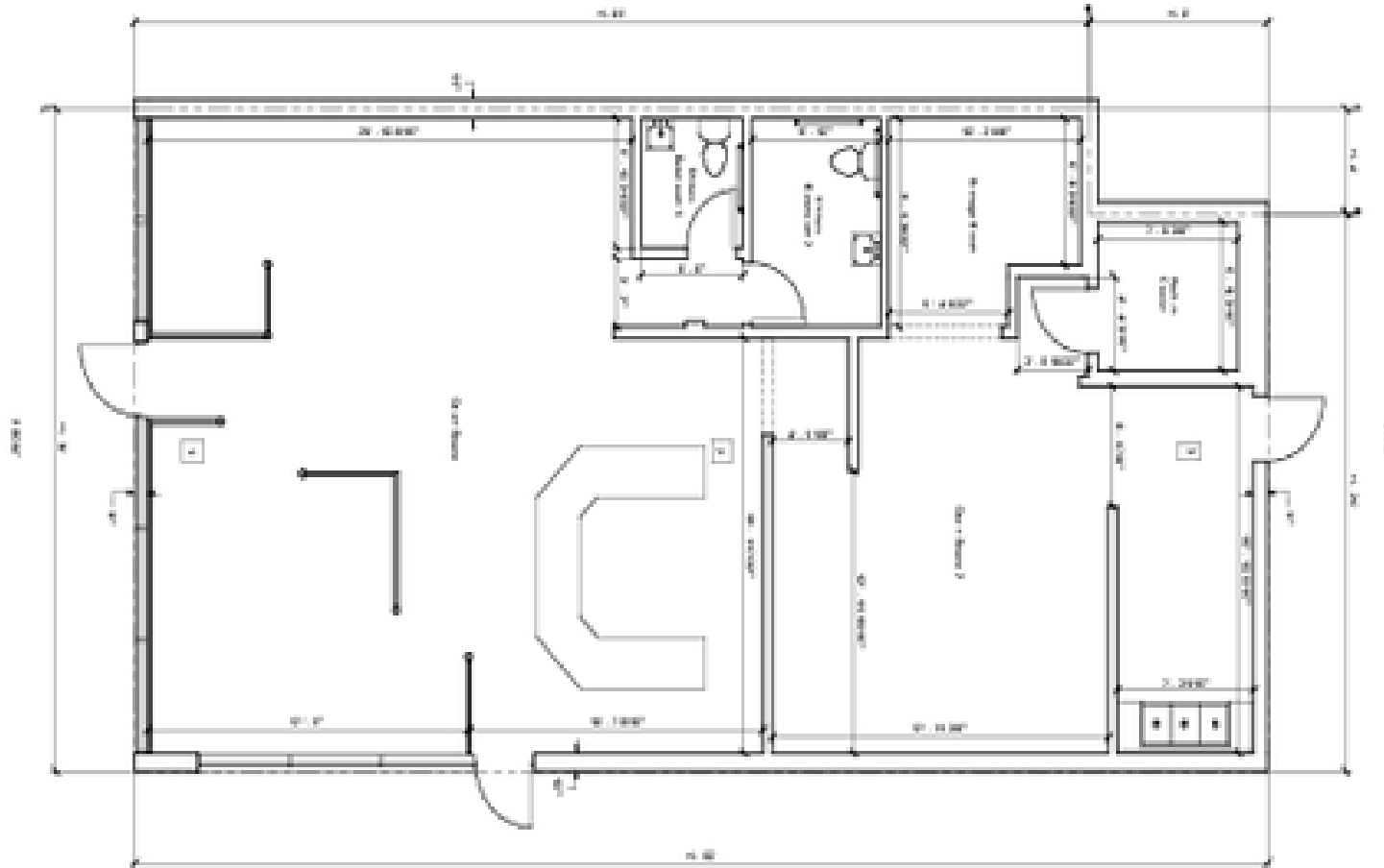

Alex Aydelotte
Partner
T: 772.223.3646
E: alex@florida-commercial.net



151,246 SF
Stuart, FL

FLOOR PLAN

Unit 806 - #16

1,977 SF

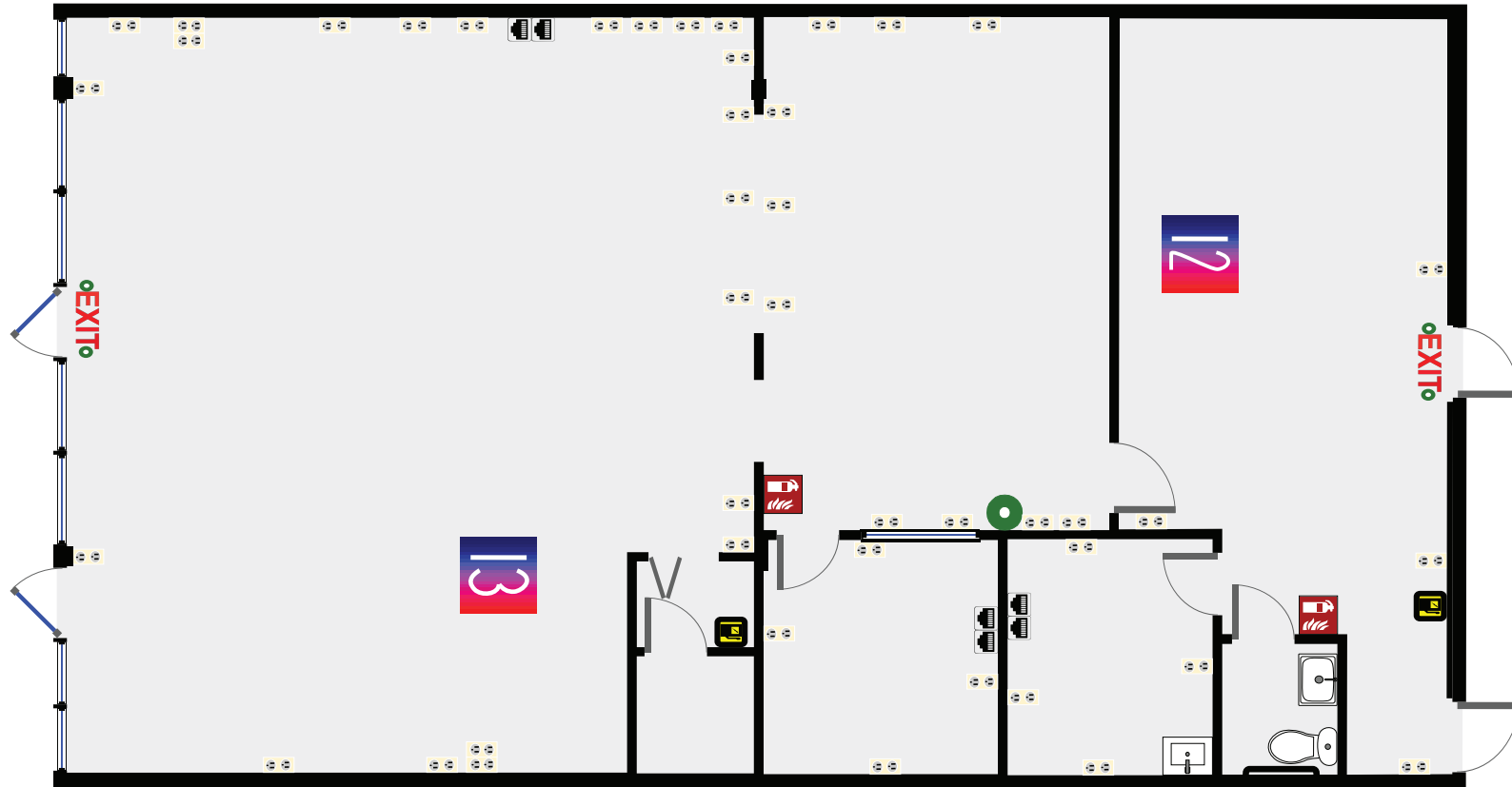

Alex Aydelotte
Partner
T: 772.223.3646
E: alex@florida-commercial.net



151,246 SF
Stuart, FL

309 SE Osceola Street #104 • Stuart, FL 34994 • 772.223.3646 • florida-commercial.net

©Florida Commercial 2021 • This offering is subject to errors, prior to sale/lease, withdrawal, or change in price, terms or conditions without notice.

FLOOR PLAN

Unit 820 - #22

540 SF

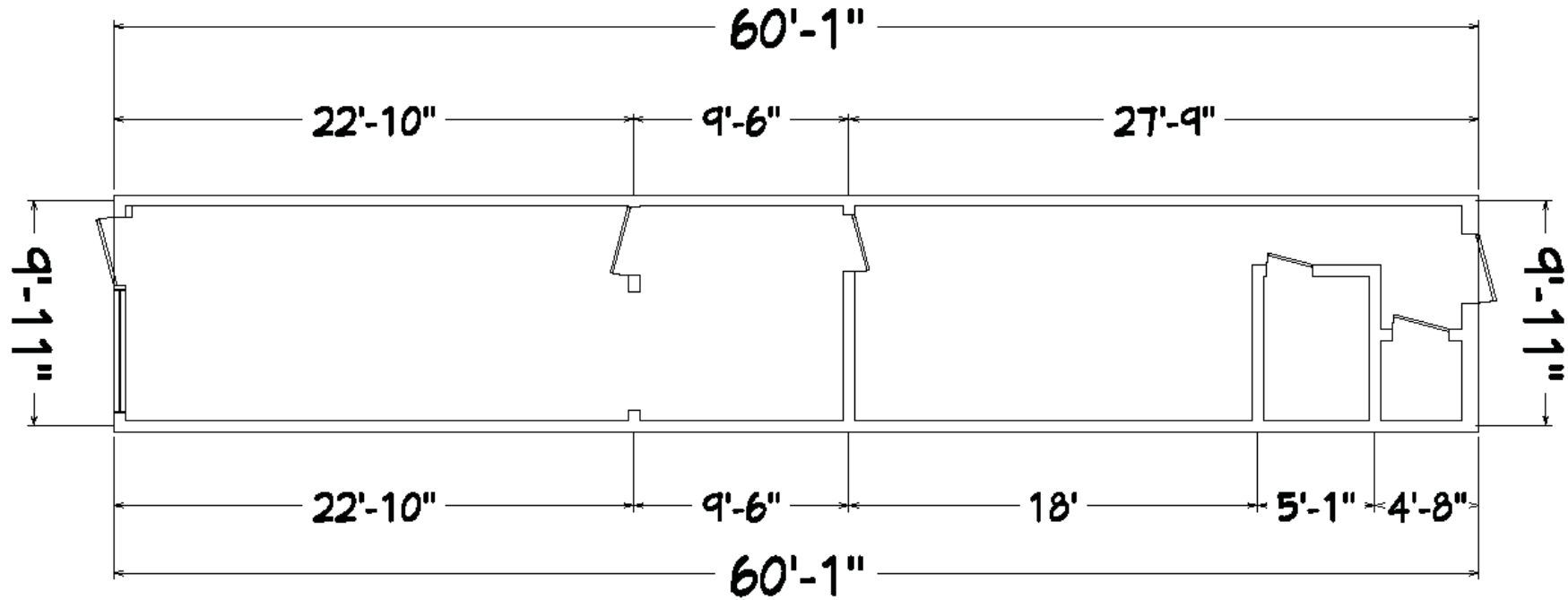

Alex Aydelotte
Partner
T: 772.223.3646
E: alex@florida-commercial.net



151,246 SF
Stuart, FL

FLOOR PLAN

Unit 824 - #24

840 SF

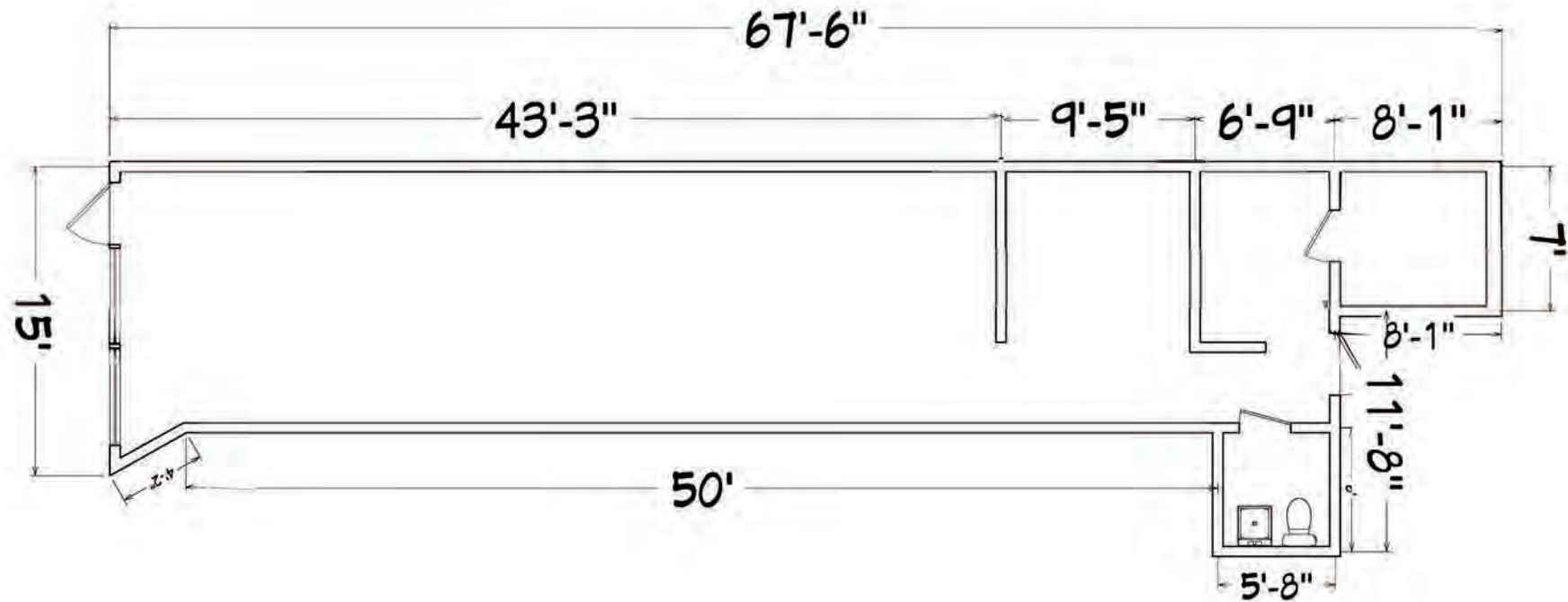

Alex Aydelotte
Partner
T: 772.223.3646
E: alex@florida-commercial.net



151,246 SF
Stuart, FL

FLOOR PLAN

Unit 848 - #29

1,200 SF

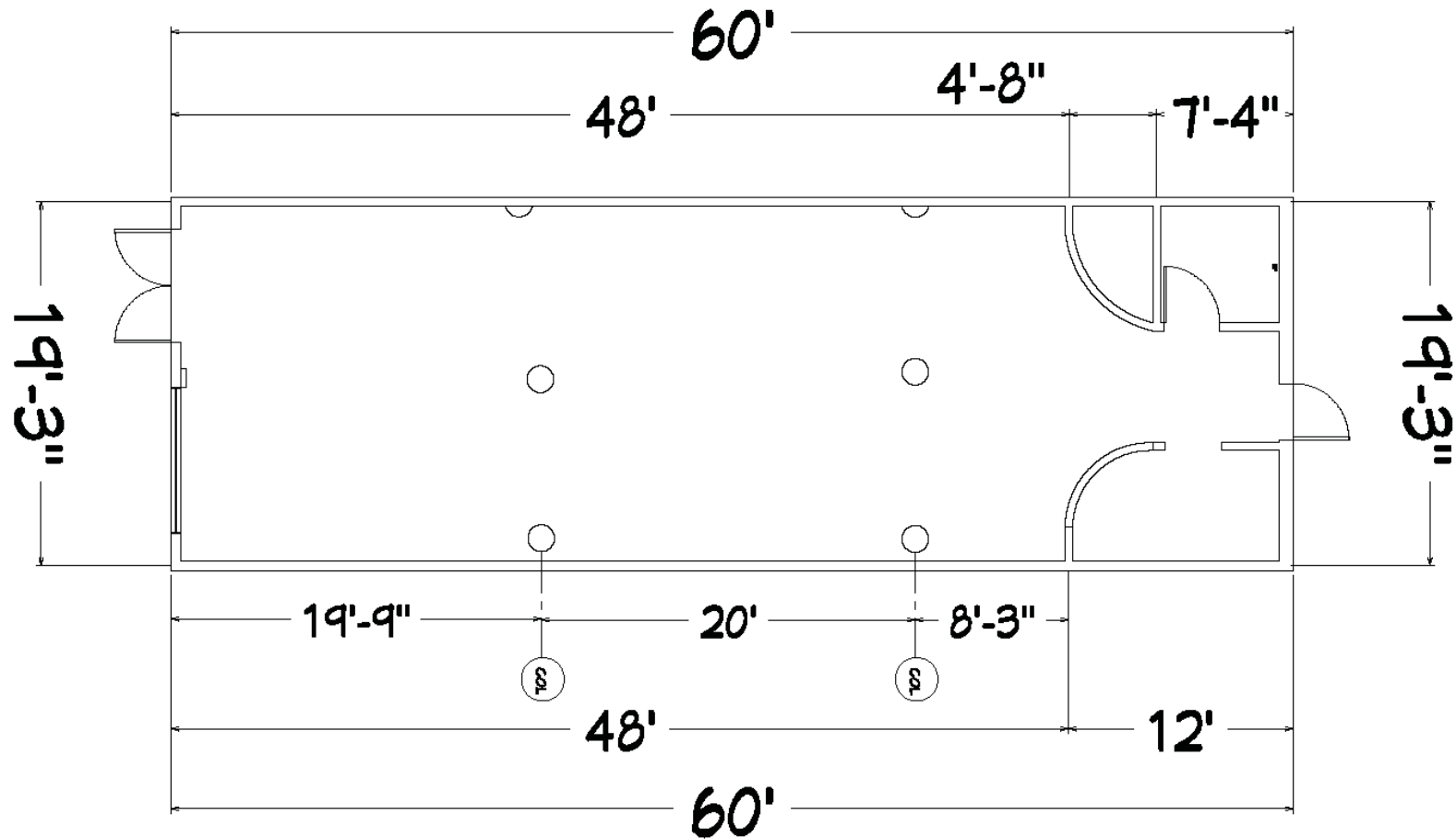

Alex Aydelotte
Partner
T: 772.223.3646
E: alex@florida-commercial.net



151,246 SF
Stuart, FL

FLOOR PLAN

Unit 890 - #40

2,233 SF

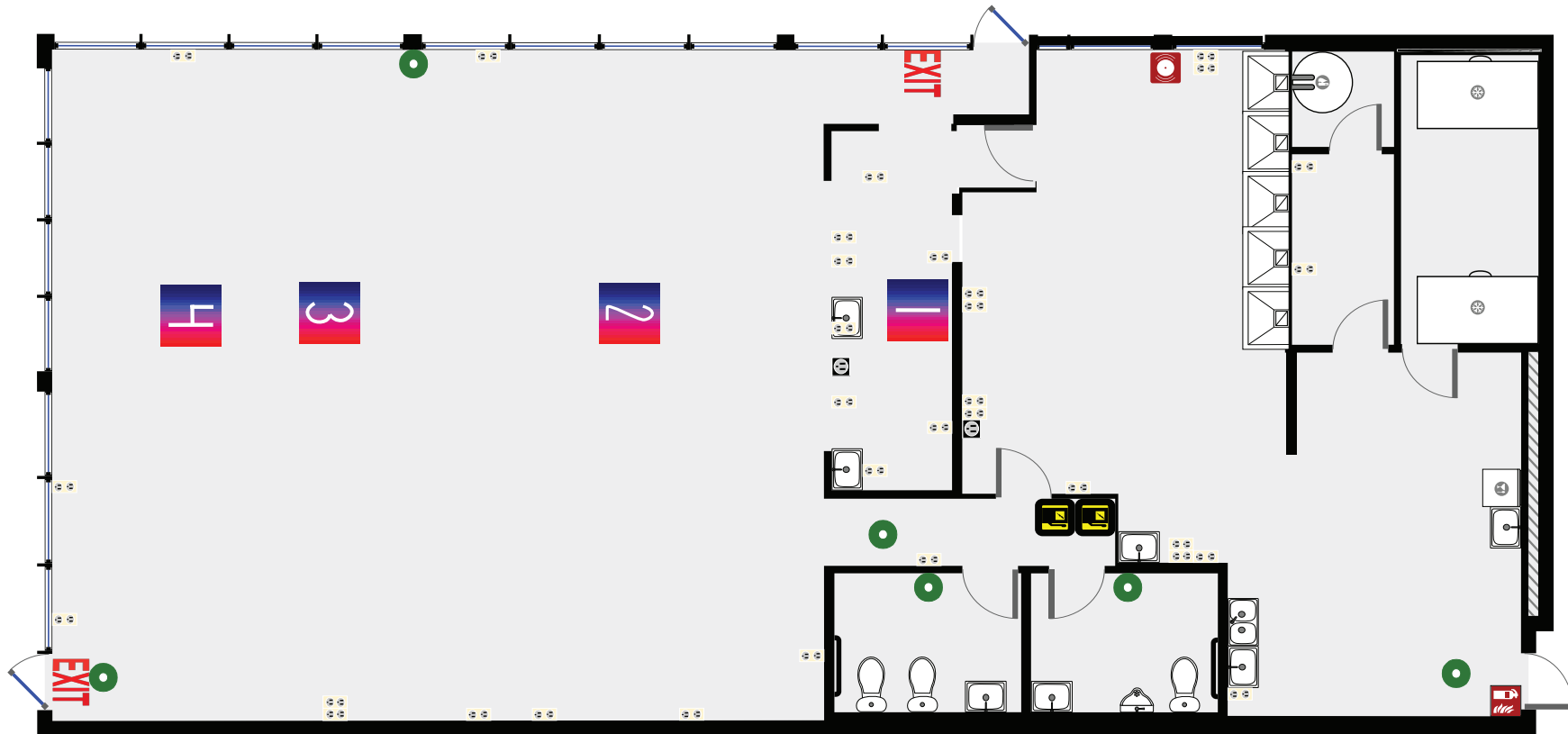

Alex Aydelotte
Partner
T: 772.223.3646
E: alex@florida-commercial.net



151,246 SF
Stuart, FL