

REVISIONS:	△
3-25-02	1

CONSULTANT:

 Landscape Architects, Inc.
 206 WEST HIGHLAND AVENUE, SUITE 204
 MILWAUKEE, WISCONSIN 53203
 PH: 414.224.1030
 FX: 414.224.8070
 E-MAIL: info@lape.com

SEAL:
 2/10
 1/8

CHIPMAN ADAMS LTD
 1550 NORTH WISCONSIN AVENUE, SUITE 5
 MILWAUKEE, WISCONSIN 53212
 TEL: 414.228.8800 FAX: 414.228.8888
 http://www.ca-llc.com

IHOP RESTAURANT
 STORE NO. 9954
 LOCATION:
 IHOP RESTAURANT
 8101 W. BROWNDEER RD
 MILWAUKEE, WI.

DATE: 02/11/02
 ISSUED FOR:
 PERMITS 01/18/02
 BIDS
 CONSTRUCTION
 SCALE: AS NOTED
 DRAWN BY: RJP
 JOB NO: 01-1616
 SHEET TITLE:
 LAYOUT PLAN
 SHEET NO:
 C2.0
 OF 5

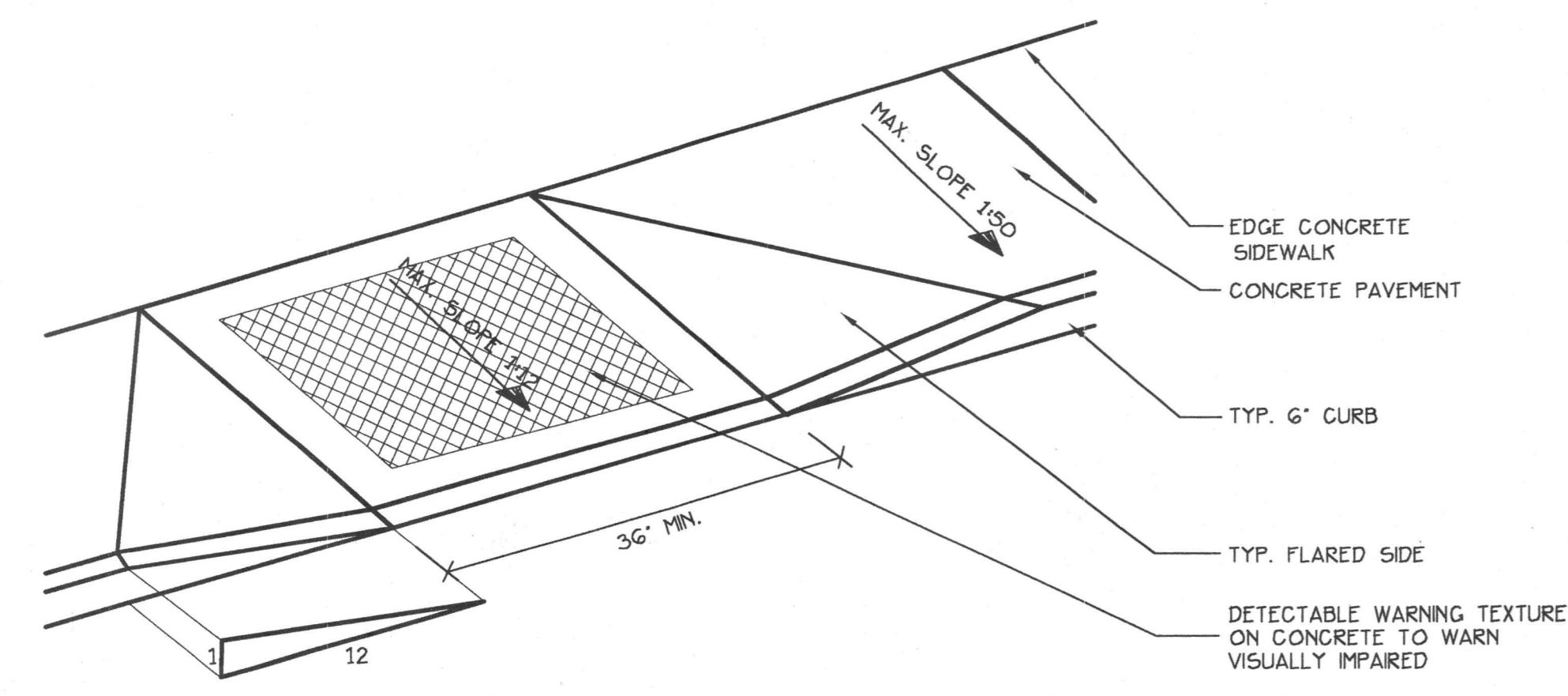

CURB RAMP 3
 NO SCALE C1.0

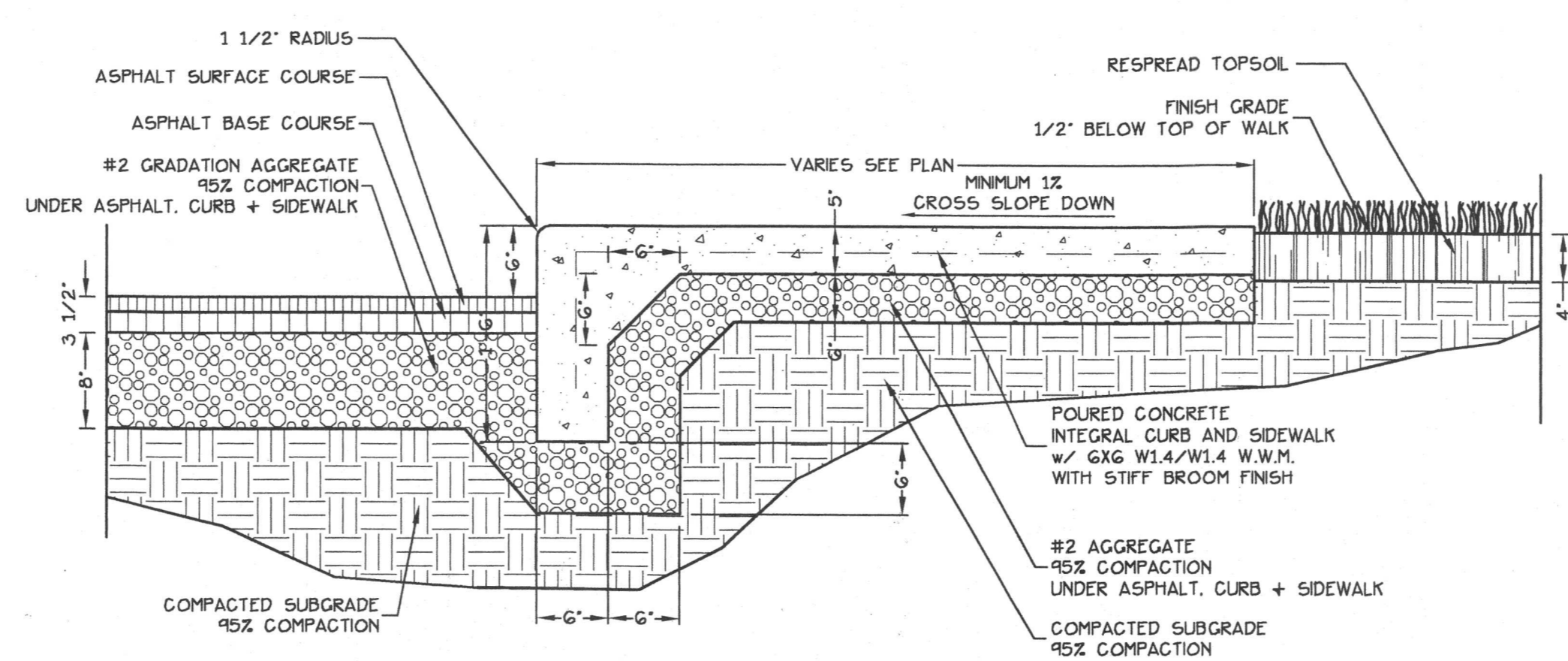

INTEGRAL WALK/CURB DETAIL 2
 NO SCALE C1.0

NOTE: PROVIDE WHEEL STOP AT PARKING STALLS WITH LESS THAN 6 FEET OF SIDEWALK IN FRONT OF STORE.

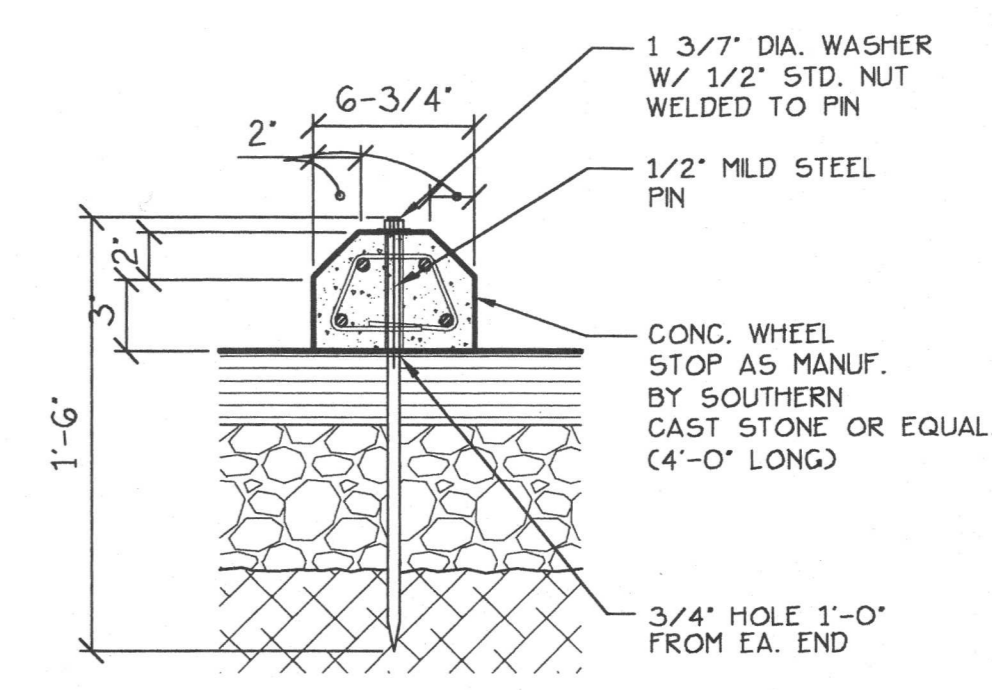

WHEELSTOP DETAIL 1
 NO SCALE C1.0

NOTE:
 CURB RAMP MUST MEET ALL APPLICABLE ADA REQUIREMENTS.

WEST BROWN DEER ROAD
 (PUBLIC ROAD)
 RIGHT-OF-WAY WIDTH = 150.00 FT

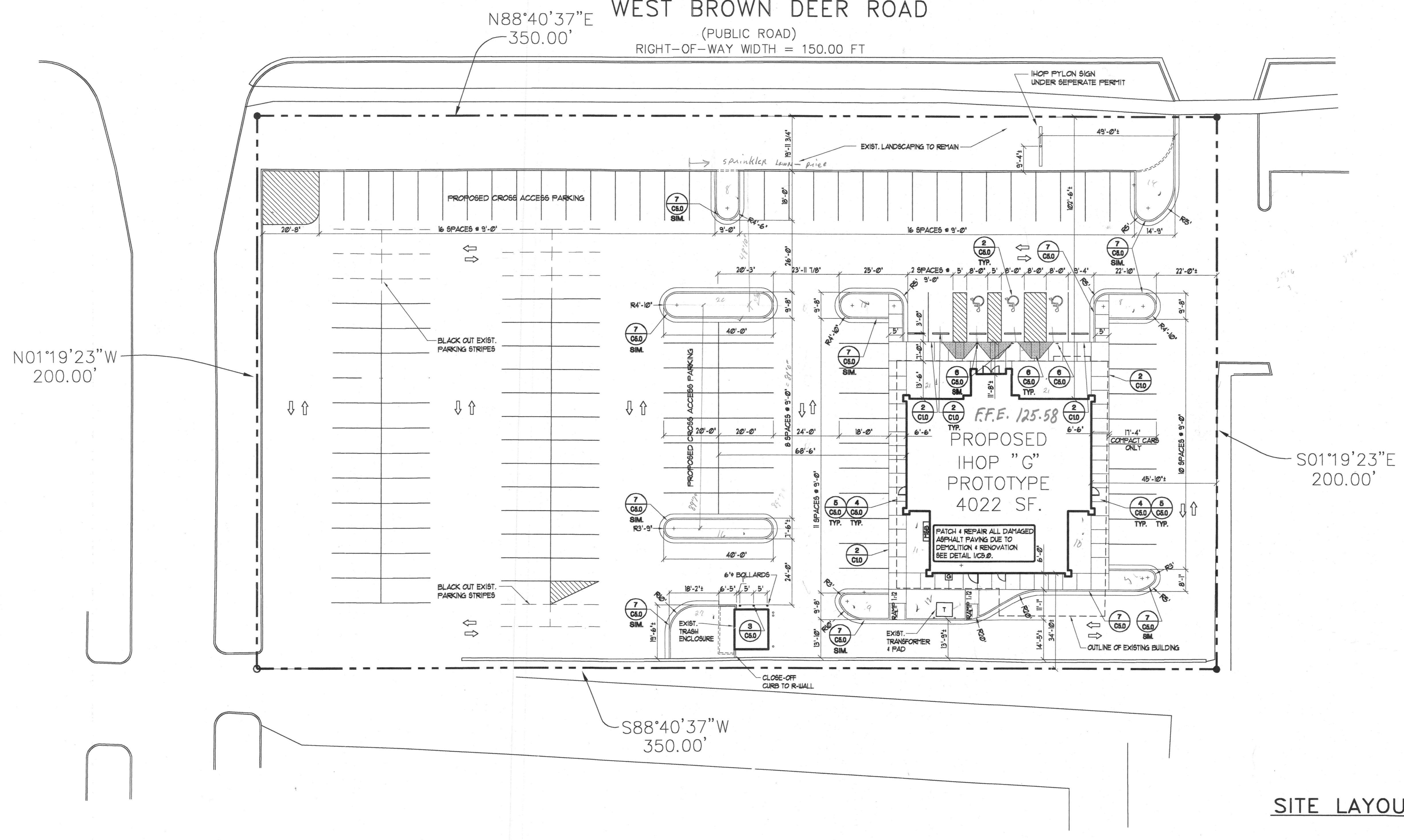

SITE LAYOUT PLAN
 SCALE: 1" = 20'-0"

