

PLANNING STUDY
CITY OF KERENS
NAVARRO COUNTY, TEXAS

ZONING DISTRICTS

PLANNING PERIOD
2007 - 2027

TIM F. GLENDENING & ASSOCIATES, INC.
3021 TRINE LANE DRIVE
PLANO, TEXAS 75085
9723946479

PLANNING AND MANAGEMENT CONSULTANTS

APRIL, 2007

FINANCED THROUGH THE OFFICE OF RURAL COMMUNITY AFFAIRS OF THE STATE OF TEXAS. The preparation of this document was financed through the provisions of a Texas Community Development Block Grant Program from the U.S. Department of Housing and Urban Development.

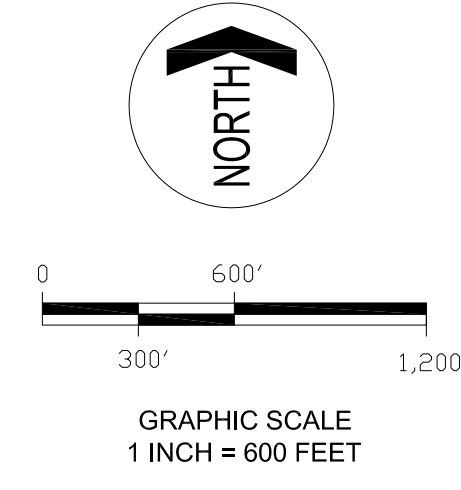

The information and data shown on this map is for planning purposes only. City personnel should be contacted to verify the location of city limits, property lines, streets, easements and all other information and data depicted.

- LEGEND**
- COUNTY PARK
 - WATER TOWER
 - SCHOOL
 - CHURCH
 - BASEBALL FIELD
 - CITY HALL
 - POST OFFICE
 - ALUMNI CENTER
 - CHAMBER OF COMMERCE
 - KERENS HEAD START CENTER
 - LIBRARY
 - FIRE DEPARTMENT

- ZONING CLASSIFICATIONS**
- A AGRICULTURAL DISTRICT
 - SF-1 SINGLE FAMILY RESIDENTIAL DISTRICT - 1
 - SF-2 SINGLE FAMILY RESIDENTIAL DISTRICT - 2
 - SF-E SINGLE FAMILY RESIDENTIAL DISTRICT - ESTATE
 - TF TWO FAMILY RESIDENTIAL (DUPLIX) DISTRICT
 - MH-1 MANUFACTURED HOME DISTRICT
 - MH-2 MANUFACTURED HOME PARK DISTRICT
 - MF MULTIFAMILY DISTRICT
 - C-1 COMMERCIAL DISTRICT - OFFICE, LIGHT RETAIL AND NEIGHBORHOOD SERVICES
 - C-2 COMMERCIAL DISTRICT - GENERAL
 - M-1 MANUFACTURING/INDUSTRIAL DISTRICT - LIGHT
 - M-2 MANUFACTURING/INDUSTRIAL DISTRICT - HEAVY
 - PD PLANNED DEVELOPMENT DISTRICT
 - FP FLOODPLAIN DISTRICT

