

2600 TELEGRAPH ROAD

BLOOMFIELD HILLS



PREMISES

- Two-story, 90,000 SF office building

AVAILABILITY

- 2nd Floor: 40,513 SF
- 1st Floor: Suites from 1,045 SF to 8,677 SF (contiguous)
- Lower Level: Storage and data room

RENTAL RATE

- Floor 2: \$26.50 psf
- Floor 1: \$23.50
- Lower Level: \$14.95 psf
- 2024 Base Year, plus electricity

FEATURES AND AMENITIES

- Building and Monument Signage Available
- Expansive two-story atrium lobby with three-level spiral staircase
- Premium detailing including marble floor, polished oak and solid brass
- Theater-style auditorium
- Magnificent wooded setting
- Ample well-lit parking including underground executive parking
- Computerized security/entry access
- Nearby fine dining, hotels and retail
- Convenient I-75 access via Square Lake Road interchange

FOR MORE INFORMATION

Daniel Canvasser
Jack Bergmann
Wade Lorimer
Newmark | nmrk.com
248.350.9500

Dan Leppink
Kojaian Management Corporation
dleppink@kojaian.com
248.644.7600

NEWMARK

MORE THAN
BUILDINGS

LOCATION | BUSINESS | IMAGE | SUCCESS

KOJAIANO
KOJAIAN.COM

2600 TELEGRAPH ROAD

BLOOMFIELD HILLS

1ST FLOOR

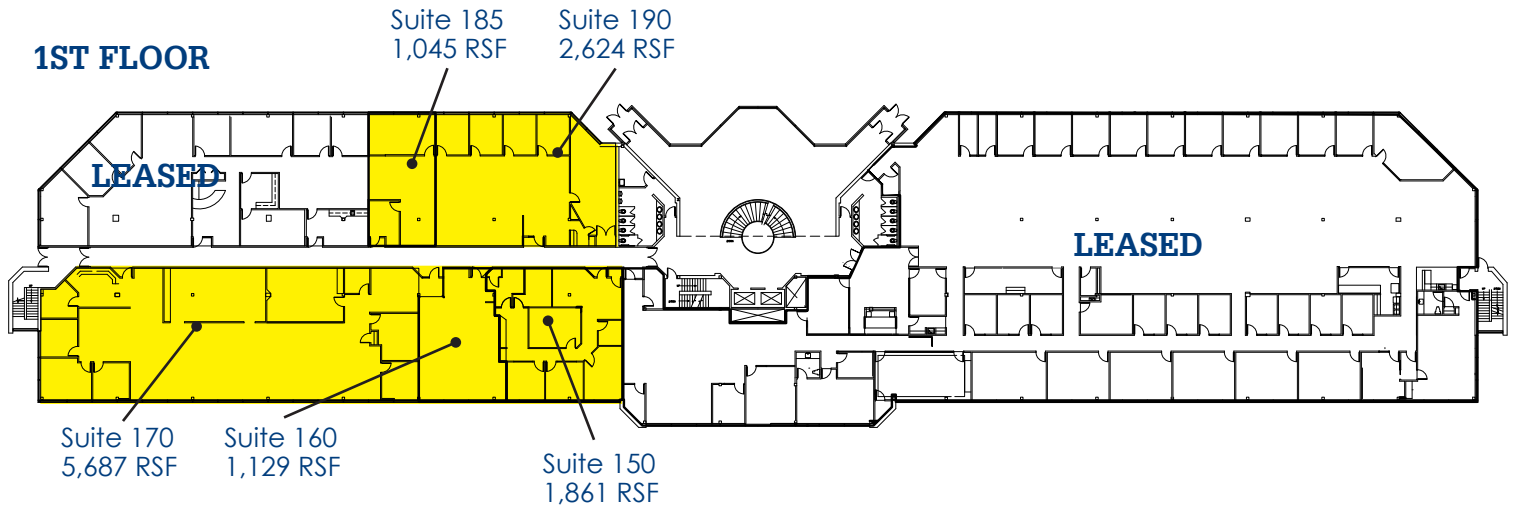

2ND FLOOR

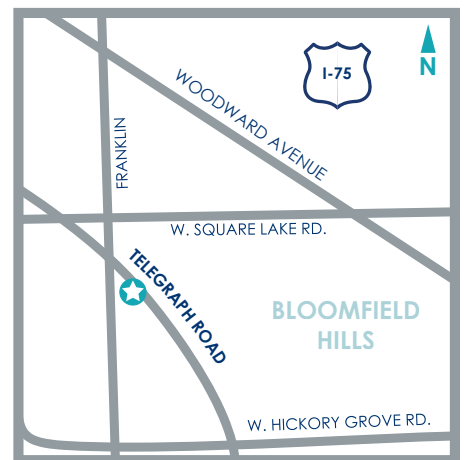
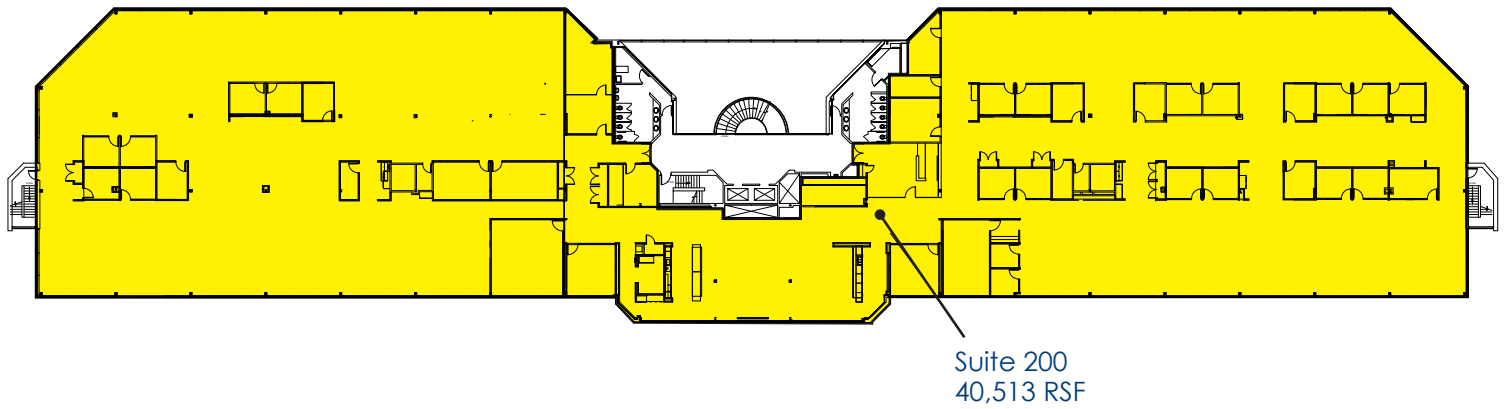

FOR MORE INFORMATION

Daniel Canvasser
Jack Bergmann
Wade Lorimer
Newmark | nmrk.com
248.350.9500

Dan Leppink
Kojaian Management Corporation
dleppink@kojaian.com
248.644.7600