

1600 N Stemmons Fwy, Ste. 103 & 104, Carrollton, TX 75006

FOR SUBLEASE

**TYPE** Office

**SIZE** +/- 644 SF - 1,374 SF

**PRICE** Contact Agent

**ZONED** Freeway

### PROPERTY VITALS

Ste. 103 - 644 SF

Ste. 104 - 730 SF

(1,374 SF Contiguous)

- Lease expires: 5/31/2027
- Can be demised
- Clear Height: 14'
- Great Access to I-35 & LBJ Freeway
- Available Now



### EXCLUSIVELY OFFERED BY:

Daniel Segreto

(214) 566-9052

dsegreto@capstonecommercial.com



**CAPSTONE  
COMMERCIAL**

4300 Sigma Rd . Suite 100

Dallas . TX 75244

T 972.250.5800

F 972.250.5801

[www.capstonecommercial.com](http://www.capstonecommercial.com)

The information contained herein was obtained from sources believed reliable; however, Capstone Commercial Real Estate Group makes no guarantees, warranties, or representation as to the completeness or accuracy thereof. The presentation of this property is submitted to errors, change of price or conditions, prior sale or lease, or withdrawal without notice.

1600 N Stemmons Fwy, Ste. 103 & 104, Carrollton, TX 75006

FOR SUBLEASE



The information contained herein was obtained from sources believed reliable; however, Capstone Commercial Real Estate Group makes no guarantees, warranties, or representation as to the completeness or accuracy thereof. The presentation of this property is submitted to errors, change of price or conditions, prior sale or lease, or withdrawal without notice.

1600 N Stemmons Fwy, Ste. 103 & 104, Carrollton, TX 75006

FOR SUBLEASE



The information contained herein was obtained from sources believed reliable; however, Capstone Commercial Real Estate Group makes no guarantees, warranties, or representation as to the completeness or accuracy thereof. The presentation of this property is submitted to errors, change of price or conditions, prior sale or lease, or withdrawal without notice.

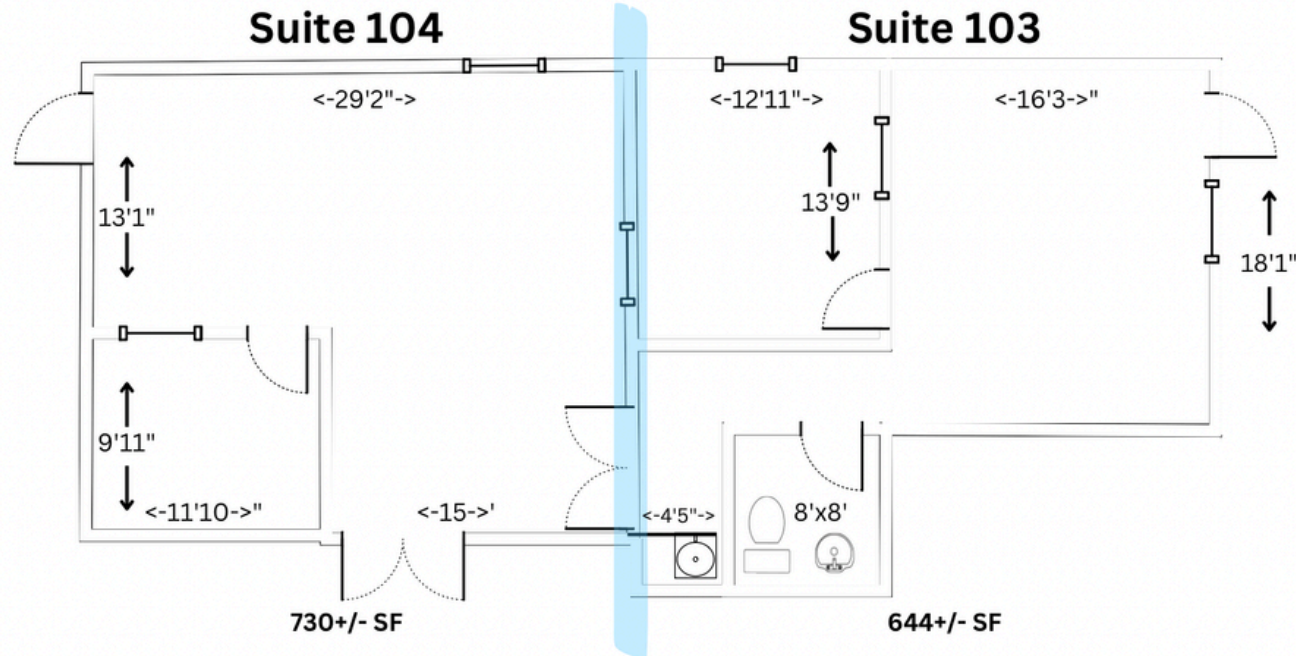

Floor Plan

1600 N Stemmons Fwy, Ste. 103 & 104, Carrollton, TX 75006

FOR SUBLEASE

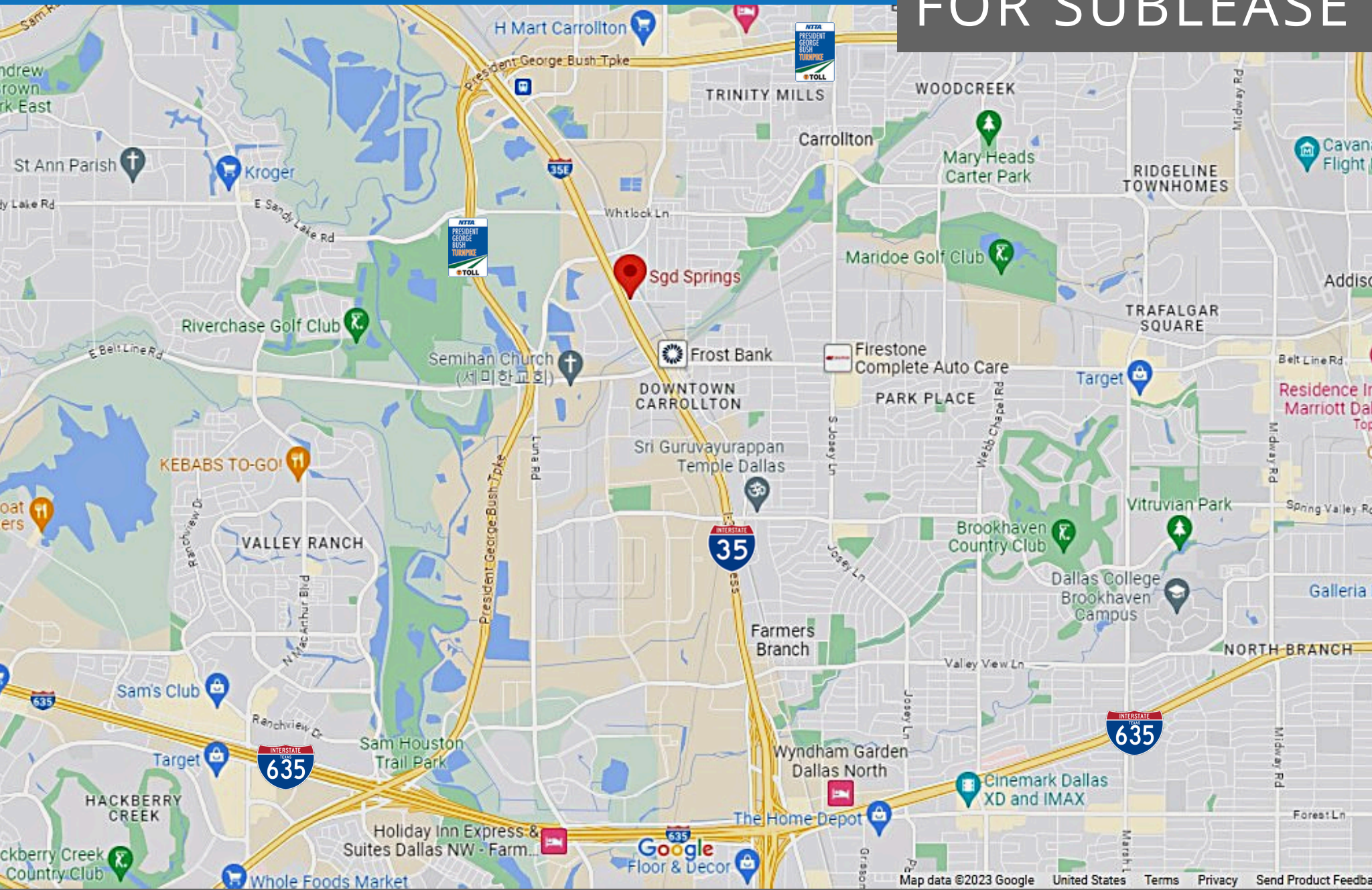

The information contained herein was obtained from sources believed reliable; however, Capstone Commercial Real Estate Group makes no guarantees, warranties, or representation as to the completeness or accuracy thereof. The presentation of this property is submitted to errors, change of price or conditions, prior sale or lease, or withdrawal without notice.



# Information About Brokerage Services

Texas law requires all real estate license holders to give the following information about brokerage services to prospective buyers, tenants, sellers and landlords.

### TYPES OF REAL ESTATE LICENSE HOLDERS:

- A BROKER is responsible for all brokerage activities, including acts performed by sales agents sponsored by the broker.
- A SALES AGENT must be sponsored by a broker and works with clients on behalf of the broker.

### A BROKER'S MINIMUM DUTIES REQUIRED BY LAW [A client is the person or party that the broker represents]:

- Put the interests of the client above all others, including the broker's own interests;
- Inform the client of any material information about the property or transaction received by the broker;
- Answer the client's questions and present any offer to or counter-offer from the client; and
- Treat all parties to a real estate transaction honestly and fairly.

### A LICENSE HOLDER CAN REPRESENT A PARTY IN A REAL ESTATE TRANSACTION:

**AS AGENT FOR OWNER (SELLER/LANDLORD):** The broker becomes the property owner's agent through an agreement with the owner, usually in a written listing to sell or property management agreement. An owner's agent must perform the broker's minimum duties above and must inform the owner of any material information about the property or transaction known by the agent, including information disclosed to the agent or subagent by the buyer or buyer's agent.

**AS AGENT FOR BUYER/TENANT:** The broker becomes the buyer/tenant's agent by agreeing to represent the buyer, usually through a written representation agreement. A buyer's agent must perform the broker's minimum duties above and must inform the buyer of any material information about the property or transaction known by the agent, including information disclosed to the agent by the seller or seller's agent.

**AS AGENT FOR BOTH - INTERMEDIARY:** To act as an intermediary between the parties the broker must first obtain the written agreement of each party to the transaction. The written agreement must state who will pay the broker and, in conspicuous bold or underlined print, set forth the broker's obligations as an intermediary. A broker who acts as an intermediary:

- Must treat all parties to the transaction impartially and fairly;
- May, with the parties' written consent, appoint a different license holder associated with the broker to each party (owner and buyer) to communicate with, provide opinions and advice to, and carry out the instructions of each party to the transaction.
- Must not, unless specifically authorized in writing to do so by the party, disclose:
  - o that the owner will accept a price less than the written asking price;
  - o that the buyer/tenant will pay a price greater than the price submitted in a written offer; and
  - o any confidential information or any other information that a party specifically instructs the broker in writing not to disclose, unless required to do so by law.

**AS SUBAGENT:** A license holder acts as a subagent when aiding a buyer in a transaction without an agreement to represent the buyer. A subagent can assist the buyer but does not represent the buyer and must place the interests of the owner first.

### TO AVOID DISPUTES, ALL AGREEMENTS BETWEEN YOU AND A BROKER SHOULD BE IN WRITING AND CLEARLY ESTABLISH:

- The broker's duties and responsibilities to you, and your obligations under the representation agreement.
- Who will pay the broker for services provided to you, when payment will be made and how the payment will be calculated.

**LICENSE HOLDER CONTACT INFORMATION:** This notice is being provided for information purposes. It does not create an obligation for you to use the broker's services. Please acknowledge receipt of this notice below and retain a copy for your records.

Capstone Commercial Real Estate Group, LLC	<u>480574</u>	<u>sburris@capstonecommercial.com</u>	<u>(972) 250-5800</u>
Licensed Broker/Broker Firm Name or Primary Assumed Business Name	License No.	Email	Phone
<u>Steven Burris</u>	<u>450870</u>	<u>sburris@capstonecommercial.com</u>	<u>(972) 250-5858</u>
Designated Broker of Firm	License No.	Email	Phone
<u>Daniel Segreto</u>	<u>554295</u>	<u>dsegreto@capstonecommercial.com</u>	<u>(214) 566-9052</u>
Licensed Supervisor of Sales Agent/Associate	License No.	Email	Phone

Sales Agent/Associate's Name	License No.	Email	Phone
<u>Buyer/Tenant/Seller/Landlord Initials</u>			
			Date