



DAMEN COLLECTIVE

1617 & 1613 N. DAMEN AVE

 MID-AMERICA[®] URBAN

 ASANA
PARTNERS



Second generation retail and restaurant opportunities on the best block in Chicago's Bucktown neighborhood

Less than half a block from the vibrant intersection of North, Milwaukee, and Damen Avenues, plus the Damen Blue Line El stop with more than 2M riders annually

Short walking distance to The 606, Chicago's High Line Trail

Surrounded by a unique curation of international, national, and local retailers and restaurateurs

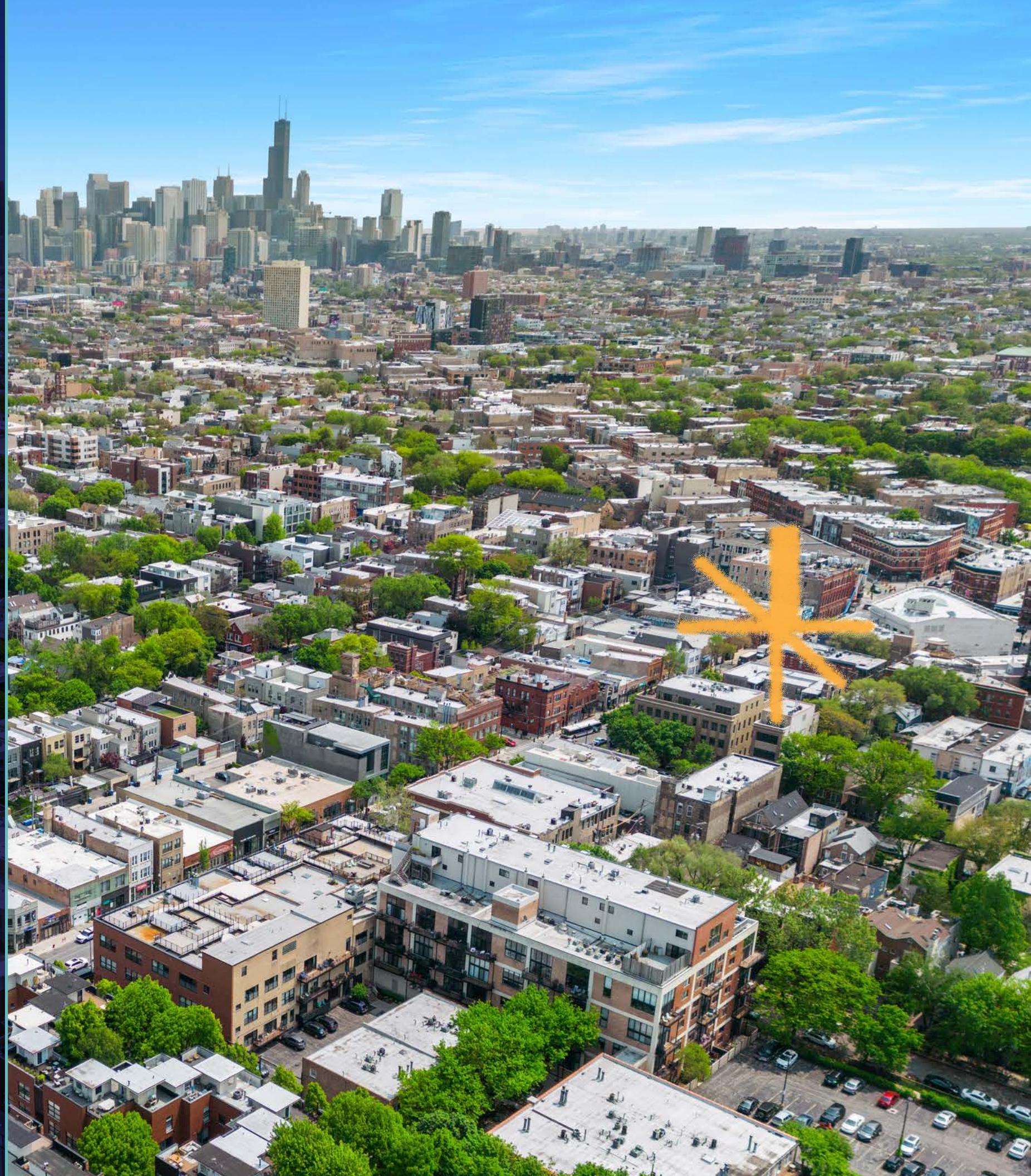



1617 N. DAMEN

3,209 SF with 27' of frontage

Second generation retail space but can convert to restaurant space

Fully customizable façade

Available immediately

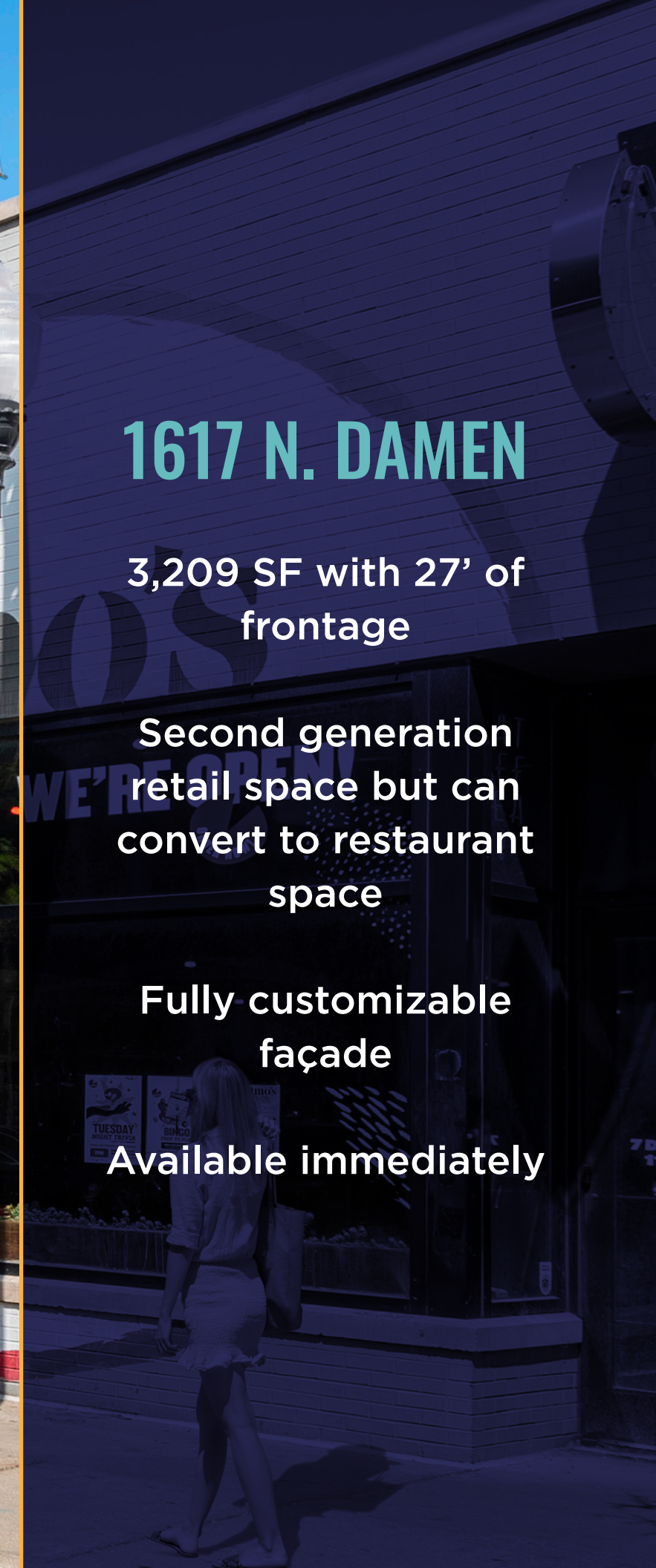

1617 N. DAMEN AVENUE

AS-BUILT FLOOR PLAN

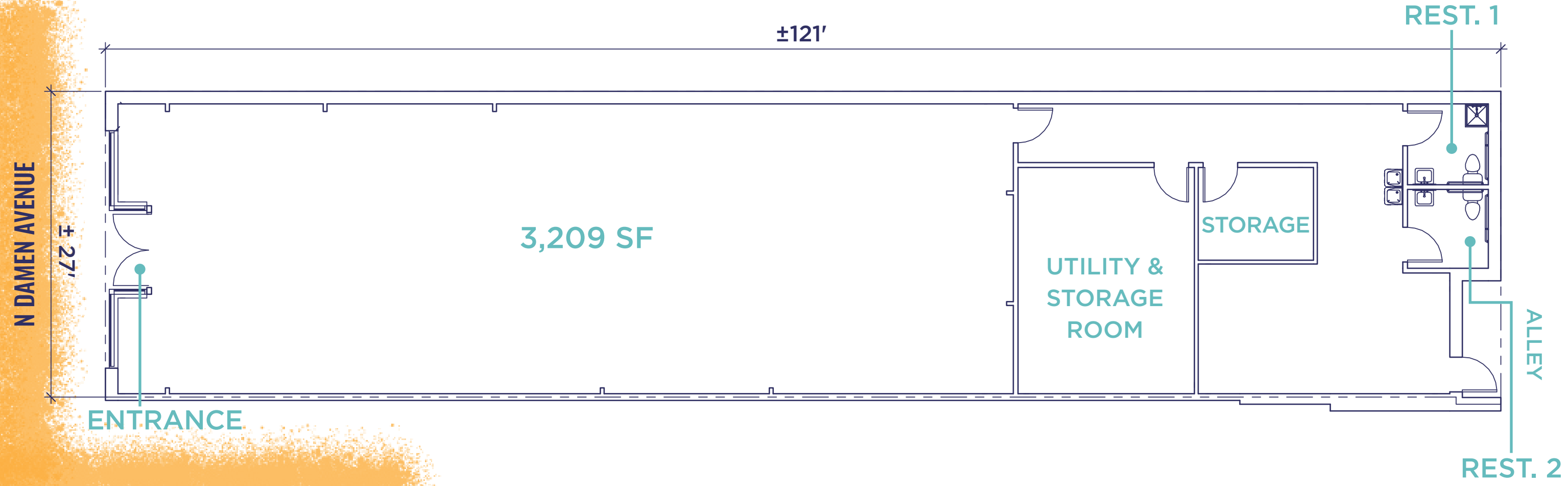

1613 N. DAMEN

2,211 SF with 22' of frontage

Second generation restaurant space, with black iron in place

Full bar and kitchen with 2 walk-in freezers

Operable storefront windows

Fully customizable façade

Available Immediately



1613 N. DAMEN AVENUE

AS-BUILT FLOOR PLAN

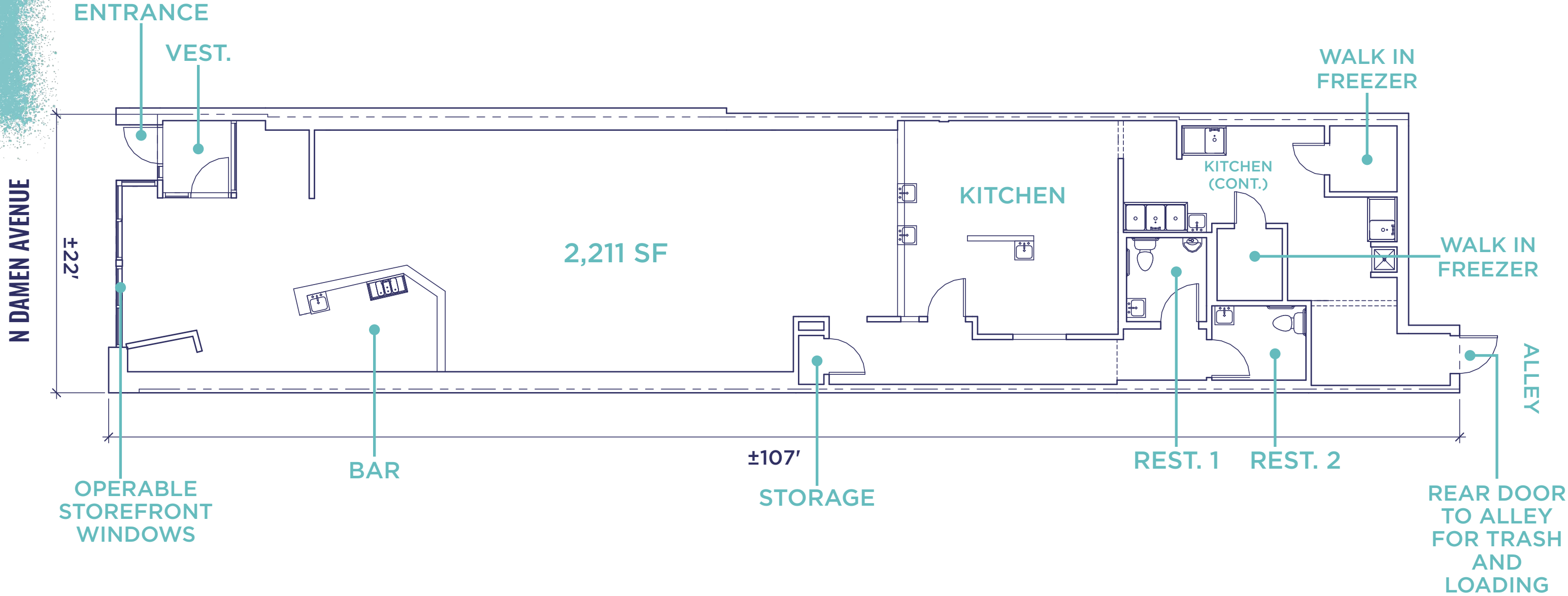

MARKET CO-TENANCY

APPAREL & ACCESSORIES



BEAUTY & COSMETICS



SERVICE



FOOD & BEVERAGE



DEMOGRAPHICS

TOTAL POPULATION

.25 mile	.5 mile	1 mile
4,589	19,999	66,041

AVERAGE HOUSEHOLD INCOME

.25 mile	.5 mile	1 mile
\$197,068	\$213,892	\$179,321

RETAIL SPENDING

1 mile

 \$478,817,213

RESTAURANT SPENDING

1 mile

 \$216,781,842

NEIGHBORHOOD MAP

LOGAN SQUARE

LAKEVIEW

LINCOLN PARK

BUCKTOWN

DAMEN CORRIDOR

OLD TOWN

WICKER PARK

GOLD COAST

MICHIGAN AVENUE

RIVER NORTH

STREETERVILLE

**WEST LOOP/
FULTON MARKET
DISTRICT**

LOOP

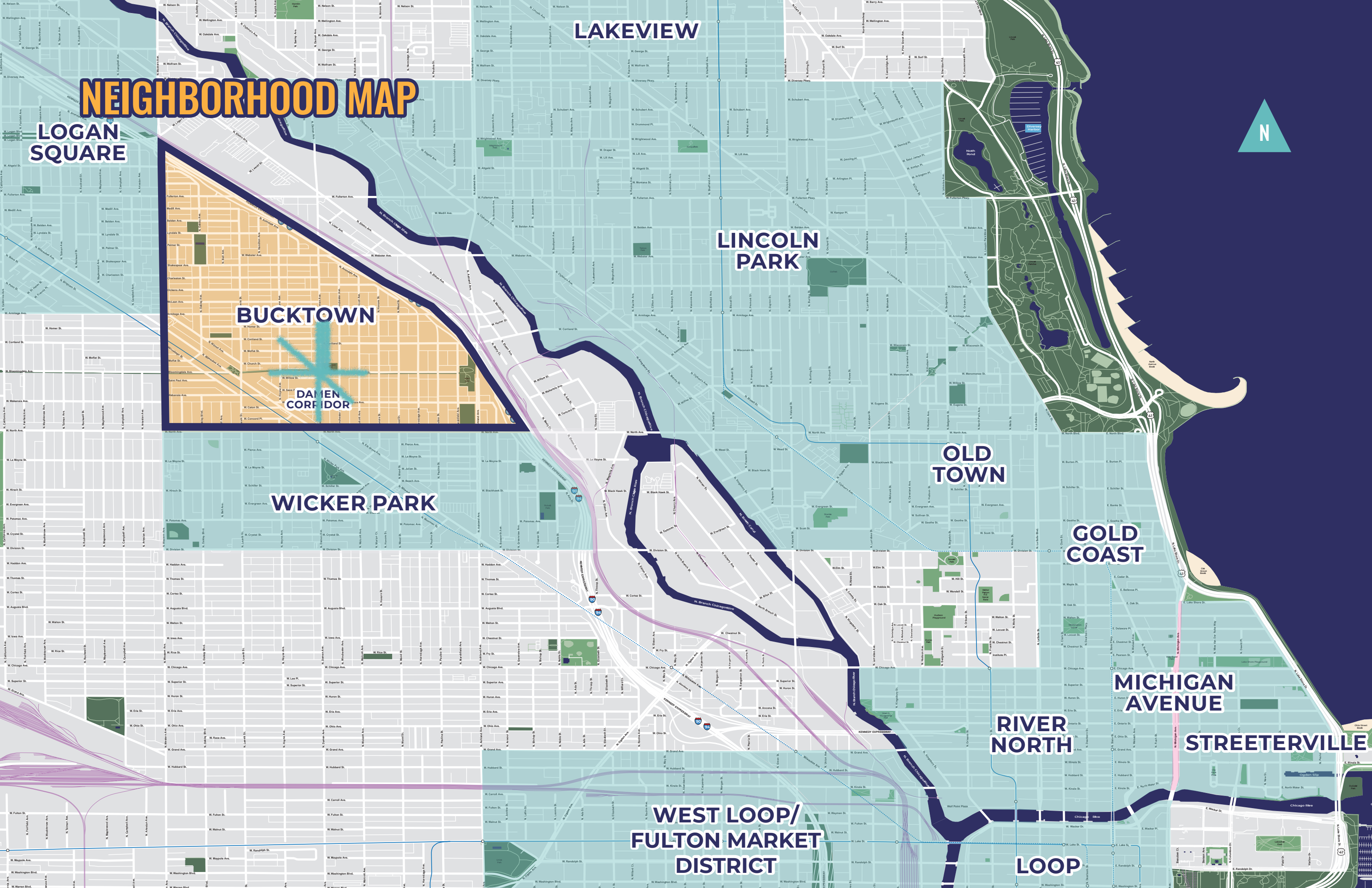

STREET MAP



DAMEN COLLECTIVE PORTFOLIO OWNED BY



MARKET MAP

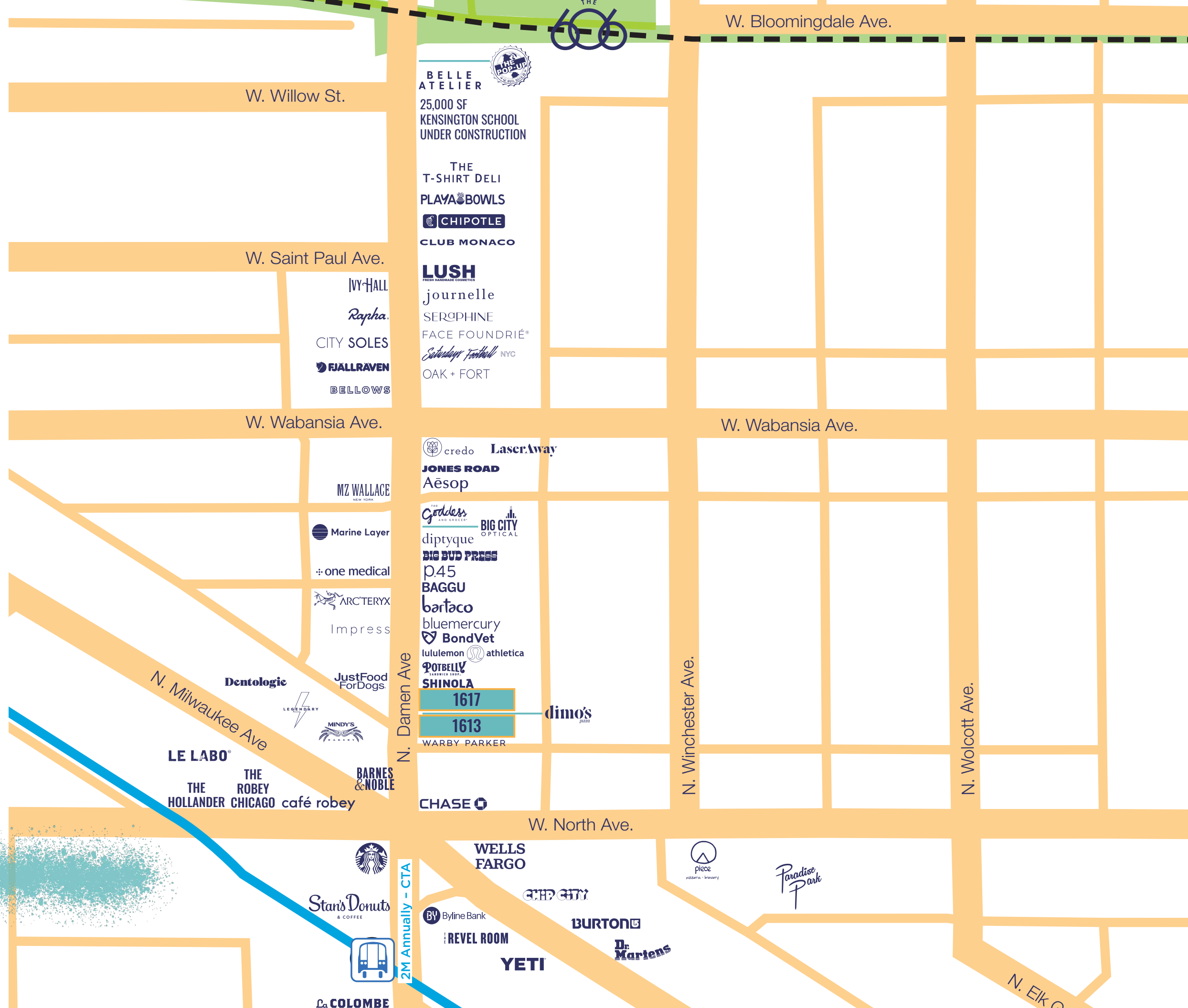

W. Bloomingdale Ave.

W. Willow St.

W. Saint Paul Ave.

W. Wabansia Ave.

W. Wabansia Ave.

N. Milwaukee Ave

N. Damen Ave

N. Winchester Ave.

N. Wolcott Ave.

W. North Ave.

2M Annually - CTA

N. Elk St.

BELLE ATELIER
25,000 SF
KENSINGTON SCHOOL
UNDER CONSTRUCTION

THE
T-SHIRT DELI
PLAYA BOWLS
CHIPOTLE
CLUB MONACO

IVY HALL
Rapha.
CITY SOLES
FJALLRAVEN
BELLOWS

LUSH
FRESH HANDMADE COSMETICS
journelle
SERAPHINE
FACE FOUNDRIE®
Saturday Footfall NYC
OAK + FORT

MZ WALLACE
NEW YORK
Marine Layer
one medical
ARC'TERYX
Impress

credo LaserAway
JONES ROAD
Aesop
The Goddess AND GROCERY
BIG CITY OPTICAL
diptyque
BIG BUD PRESS
p45
BAGGU
bartaco
bluemercury
BondVet
lululemon athletica
POTBELLY SANDWICH SHOP
SHINOLA

1617
1613
WARBY PARKER
dimo's pizza

LE LABO®
THE HOLLANDER CHICAGO
THE ROBEY
café robeY

BARNES & NOBLE

CHASE

Starbucks
Stan's Donuts & COFFEE



La COLOMBE

WELLS FARGO
CTD CITY
Byline Bank
REVEL ROOM
YETI
BURTON
Dr. Martens



Paradise Park



DAMEN COLLECTIVE

1617 & 1613 N. DAMEN AVE

LARA KEENE

Mid-America Real Estate

Principal

630.481.4038

lkeene@midamericagr.com

KELLY NICKELE

Mid-America Real Estate

Vice President

630.954.7513

knickele@midamericagr.com

GREG BAYER

Mid-America Real Estate

Principal

630.954.7441

gbayer@midamericagr.com



MID-AMERICA[®] URBAN



ASANA
PARTNERS