



FOR LEASE | INDUSTRIAL & OFFICE SPACE

Main Street Business Center

17800 SOUTH MAIN STREET • CARSON CA 90745

SUITE	TOTAL SIZE	LEASE RATE	COMMENTS
104	1,554	\$1.60	150 Office SF
204	1,554	\$1.60	150 Office SF
304	2,250	\$1.60	400 Office SF
307	2,760	\$1.55	400 Office SF
401	1,584	\$1.60	150 Office SF

JOSHUA MAY
Senior Vice President
License No. 01386831
+1 310 321 1808
josh.may@colliers.com



PRIME SOUTH BAY LOCATION

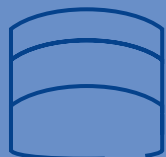

ELECTRONIC CONTROLLED GATE SECURITY



IMMEDIATE ACCESS TO THE 405, 110, AND 91 FREEWAYS

COLLIERS
2141 Rosecrans Avenue, Suite 1120
El Segundo, CA 90245
www.colliers.com

Main Street Business Center

17800 SOUTH MAIN STREET • CARSON CA 90745

LOCKBOX CODE 7-7-7-7

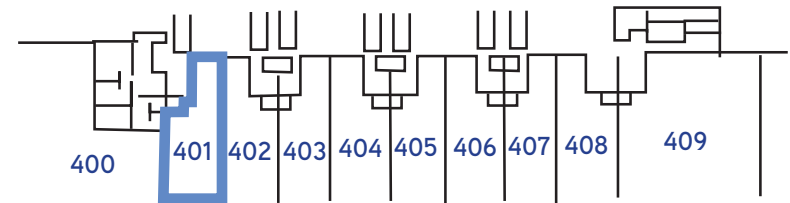
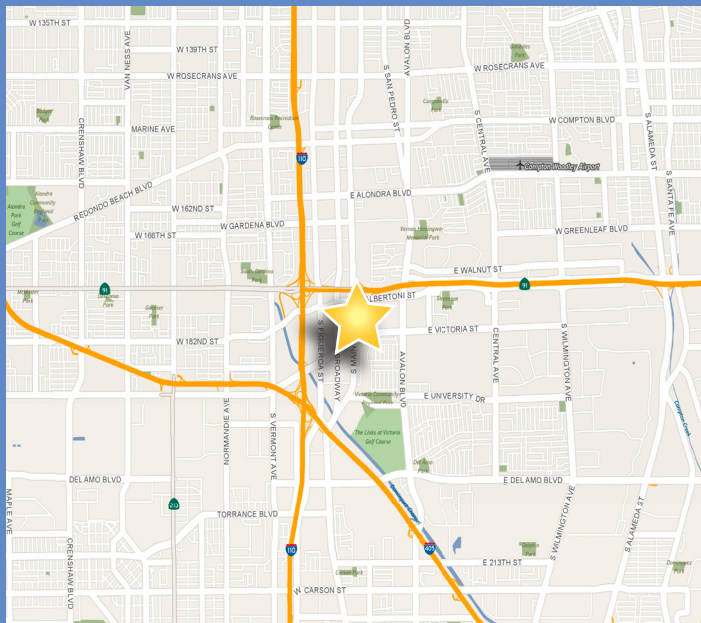
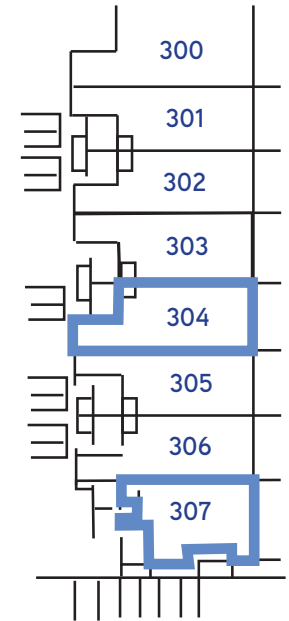
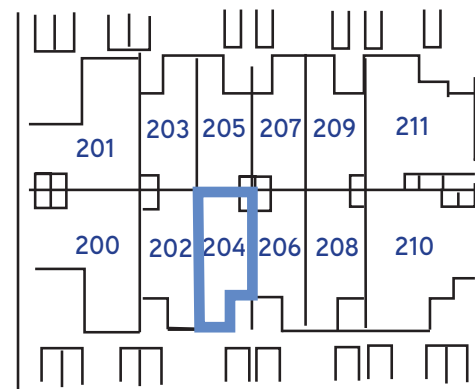
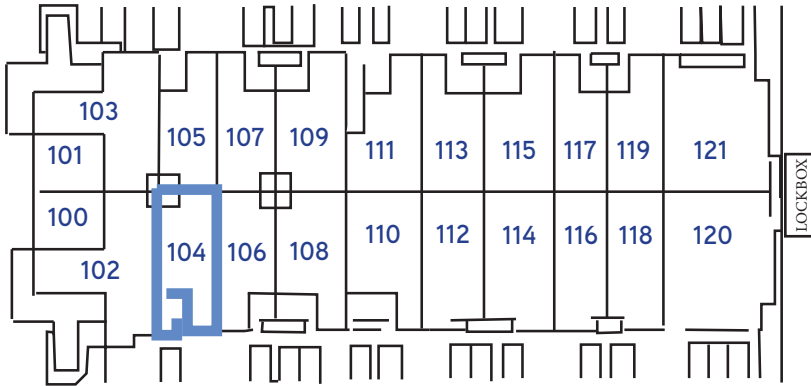

JOSHUA MAY
Senior Vice President
License No. 01386831
+1 310 321 1808
josh.may@colliers.com

COLLIERS
2141 Rosecrans Avenue, Suite
1120
El Segundo, CA 90245
www.colliers.com