

FOR LEASE

5583 Davis Blvd.
North Richland Hills, Texas



Property Information

LOCATION

West side of Davis Blvd. at Emerald Hills Way in North Richland Hills, Texas. Building is at a lighted intersection and is 1 mile north of NE Loop 820.

SUITES

Suite 100 1,550 Sq. Ft.

TRAFFIC COUNTS

36,447 vpd (2009)

COMMENTS

- Property located at a lighted intersection.
- Parking Ratio 4.2 per 1,000.
- General Office finish out.

LEASE RATE (MONTHLY)

Suite 100 \$2,325.00 Modified Gross

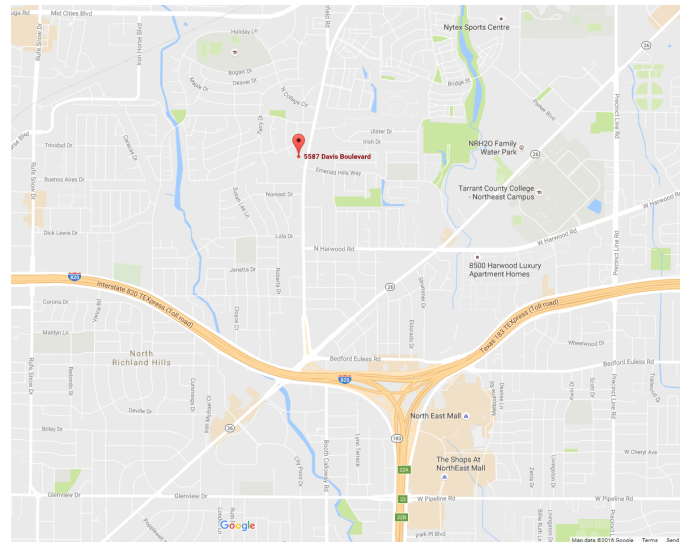

For Information

Don D. Phifer
817-427-9545 office
817-239-7100 cell
Phifer@LandDeals.com

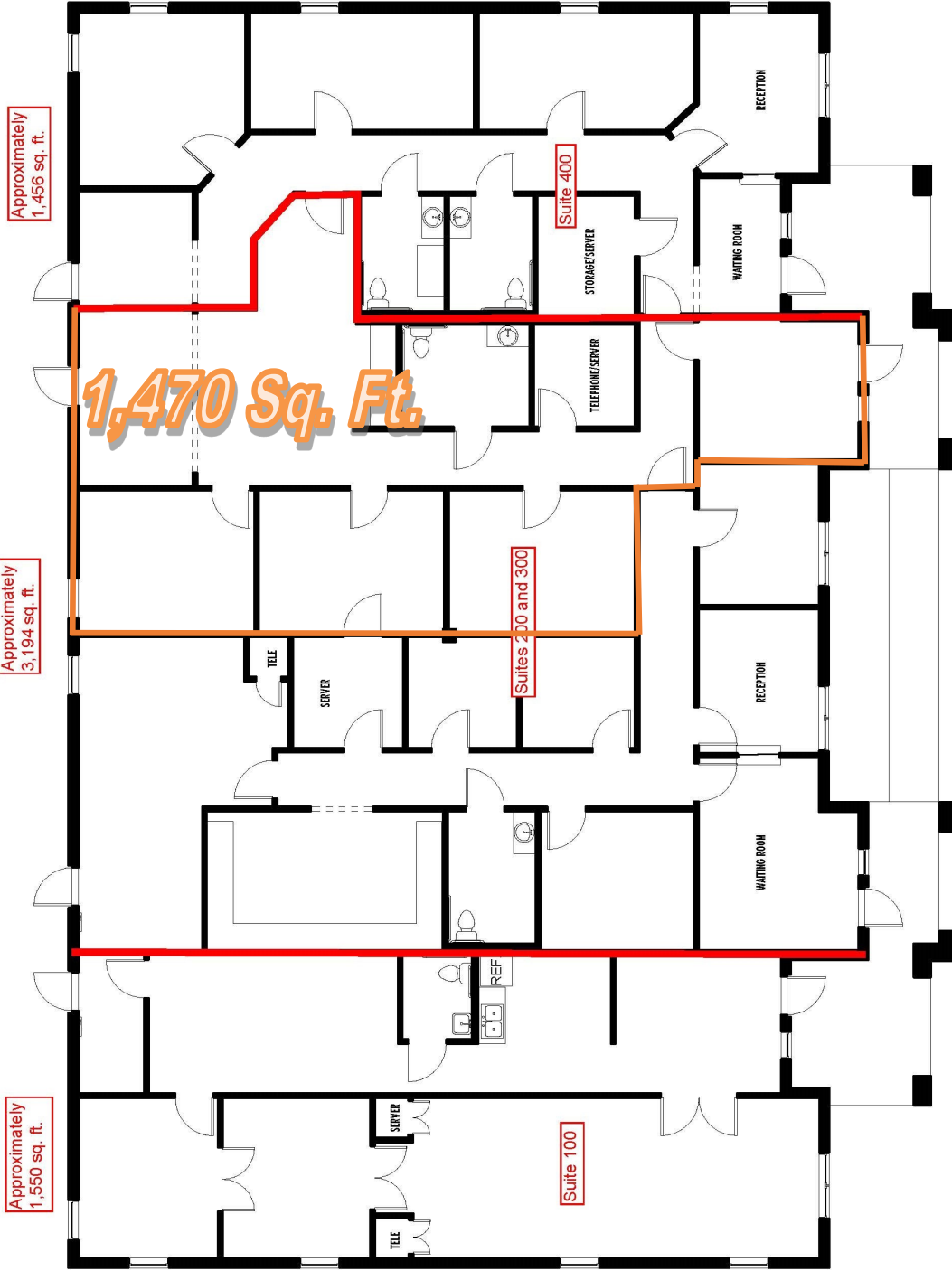

1 1/8" = 1'-0"