

# 9,078 SF

Industrial Space For Lease



## Prologis Northbrook



1000 Northbrook Parkway, Suite C1  
Suwanee, GA 30024 USA

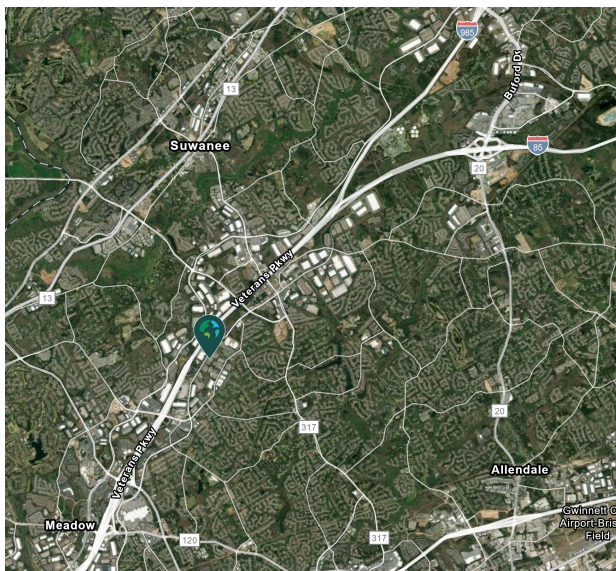

### LOCATION

- ±1 mile from I-85
- ±15 miles from I-985
- ±17.8 miles from GA 400

### FACILITY

- 131,660 SF building
- 9,078 SF available
  - 2,278 SF office
- 22' minimum clear height
- Two (2) dock doors
  - One (1) edge of dock leveler
- 40' x 40' column spacing
- 110' truck court depth
- Power: 277/480V, 225A

### ADVANTAGES AND AMENITIES

- Prologis Clear Lease® – Know your lease expenses and capital costs with greater certainty before you sign

**Your single-source service for efficient move-in and operations: [prologisessentials.com](https://www.prologisessentials.com)**



# 9,078 SF

Industrial Space For Lease



## Prologis Northbrook

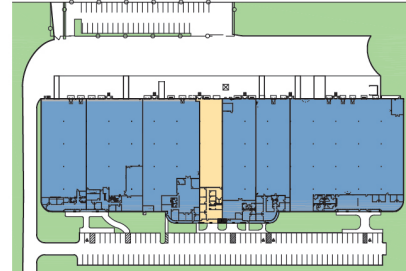

KEY PLAN

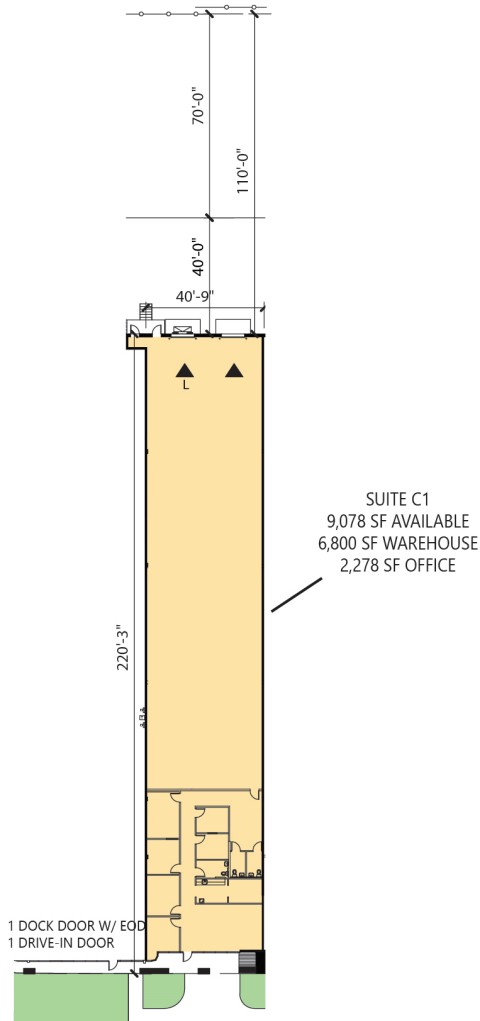

LEGEND:

- ▲ DOCK DOOR
- ▲ L DOCK DOOR W/LEVELER
- ◆ DRIVE-IN DOOR
- ▲ G ON-GRADE DOOR
- ▨ EDGE OF DOCK LEVELER
- ▧ PIT LEVELER
- LAND
- LEASED AREA
- VACANT AREA

**Prologis**

Rachel Karle  
rkarle@prologis.com  
ph +1 404 760 7260  
3350 Peachtree Road  
Suite 850  
Atlanta, GA 30326 USA