

# **E** EMPIREMAVEN

Retail Space

FOR SALE

1700

AVENUE RD.

Units 2,3,4,5,6,7

TORONTO, ON

**BRIXTON™**



## Area Information

Located at Avenue Road/Lawrence Ave and flourishing with affluence, this distinguished Toronto area is home to approximately 25,000 residents. An up-town and unique area shopping experience that allows for ample walking traffic. Out-of-city visitors frequent the up-centric shopping and food destination to explore the diverse offering of culture and fun!

To own retail space in the Empire Maven serves as a unique opportunity to become apart of this lively neighbourhood.

### FEATURES



69 P1 Visitor  
Commercial  
Spots



Proposed future  
development  
minutes away



1.8KM to Lawrence  
Station



5.9 KM  
to Highway 401

### PERMITTED USES

- wide variety of retail uses



## MAVEN COMMERCIAL



## WHY 1700 AVENUE ROAD?

With an abundance of boutiques and restaurants, the area boasts richness in specialty products and experiences. Neighbouring businesses compliment the extravagance and quality of consumers in the community.

1700 Avenue Road is the ideal retail location to become a part of a community that appreciates and supports smaller scale, high-end businesses. Entice your immediate market with luxury items, well-produced products or personalized and elegant services.

Property Details

Municipal Address:	1688 AVENUE ROAD TORONTO, Ontario
Size:	1178 SQ FT
Maintenance Fee:	\$693.60/ month
Property Taxes:	TBD (2022)
Asking Price:	<b>\$1,295,800</b>

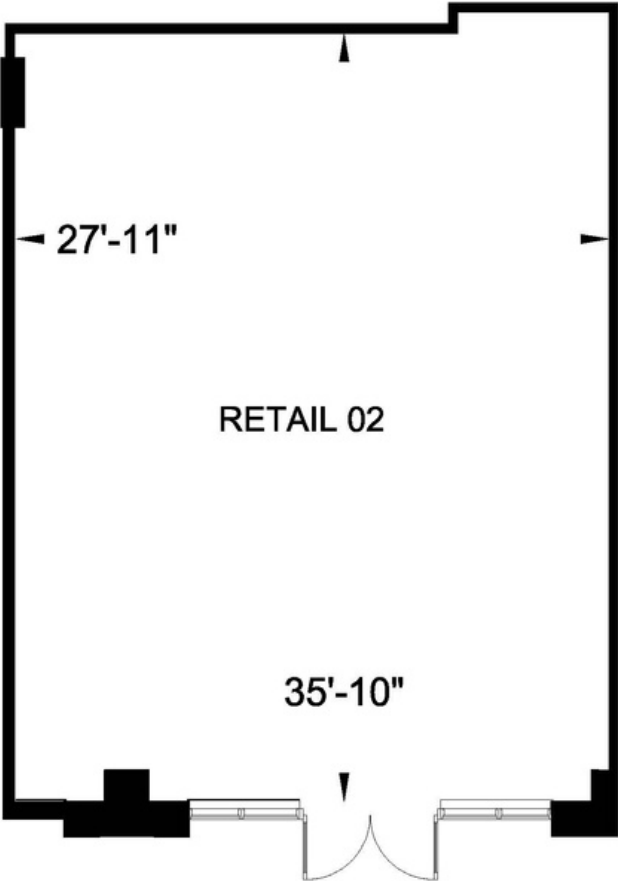

Ground Floor Level

Property Details

Municipal Address:	1692 AVENUE ROAD TORONTO, Ontario
Size:	2696 SQ FT
Maintenance Fee:	\$1,457.40 / month
Property Taxes:	TBD (2022)
Asking Price:	<b>\$2,965,600</b>

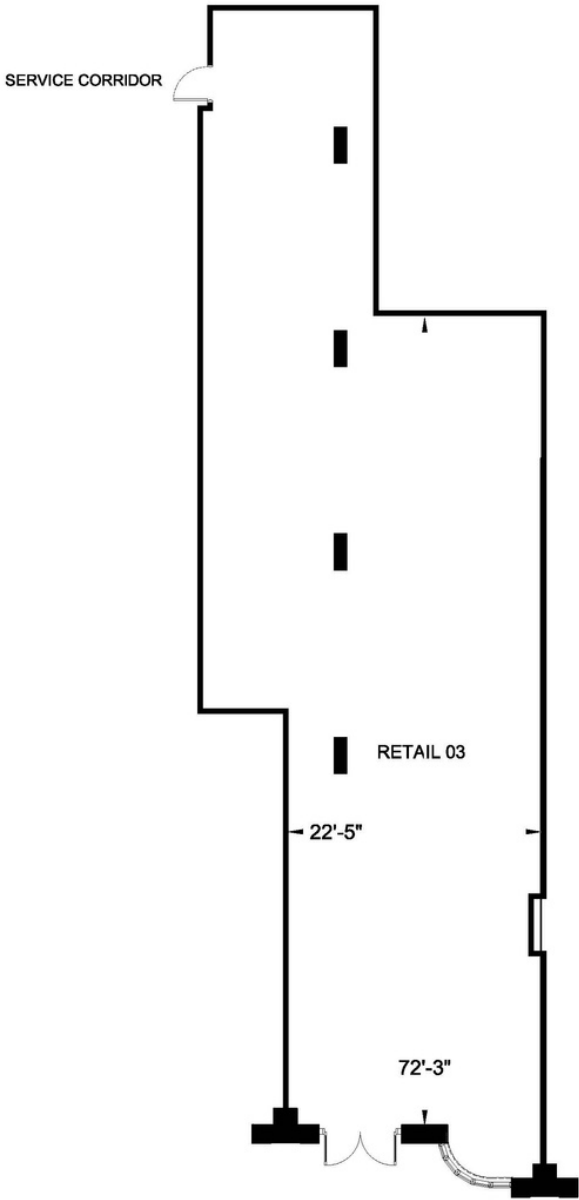

Ground Floor Level

Property Details

Municipal Address:	1696 AVENUE RD. TORONTO, Ontario
Size:	3171 SQ FT
Maintenance Fee:	\$1,716 / month
Property Taxes:	TBD (2022)
Asking Price:	<b>\$3,488,100</b>

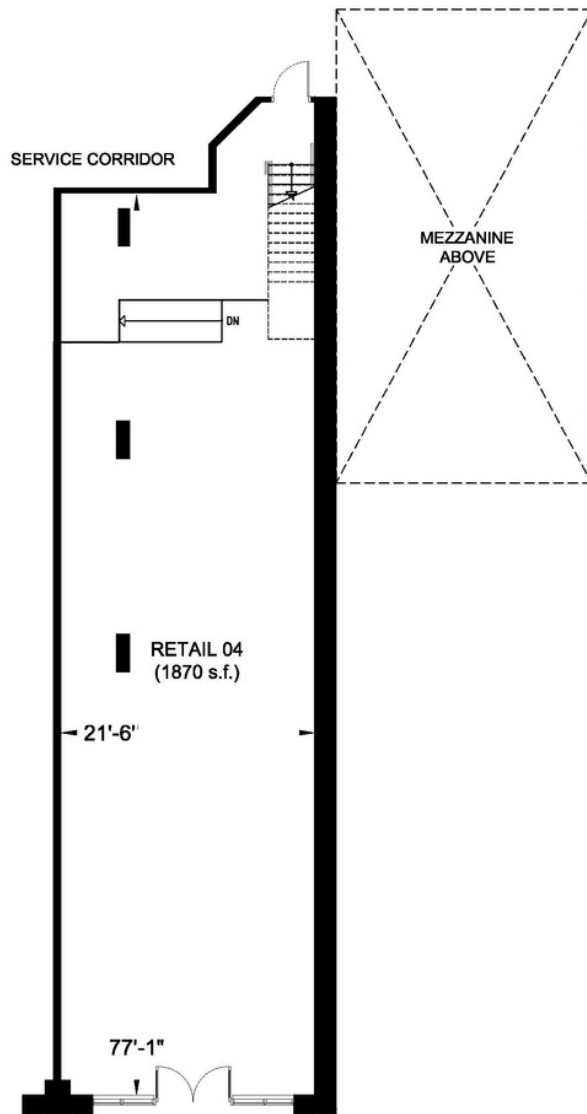

Ground Floor Level

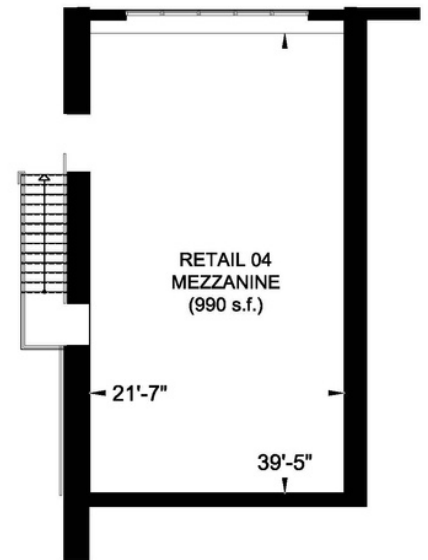

Mezzanine Level

Property Details

Municipal Address:	1702 AVENUE RD. TORONTO, Ontario
Size:	1645 SQ FT
Maintenance Fee:	\$724.20 / month
Property Taxes:	\$TBD(2022)
Asking Price:	<b>\$2,220,750</b>

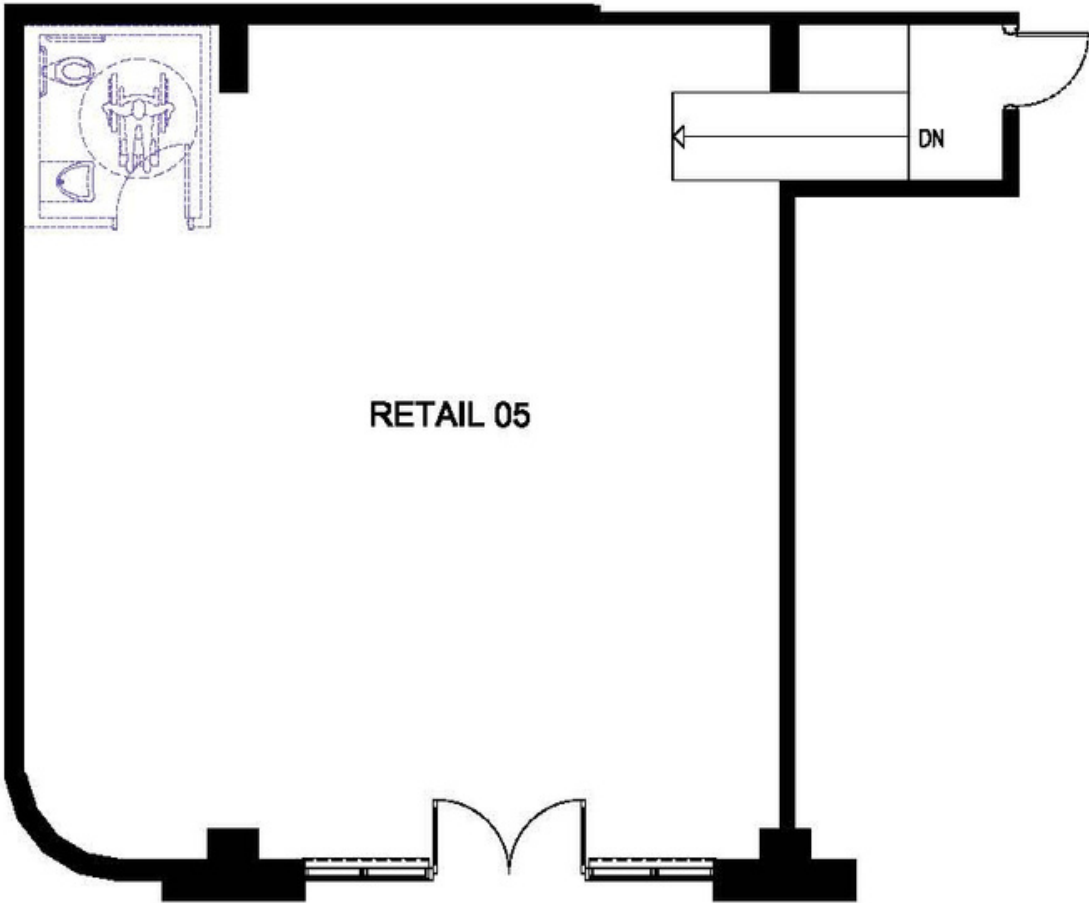

Property Details

Municipal Address:	1704A AVENUE RD. TORONTO, Ontario
Size:	1011 SQ FT
Maintenance Fee:	\$707.40 / month
Property Taxes:	\$TBD (2022)
Asking Price:	<b>\$1,364,850</b>

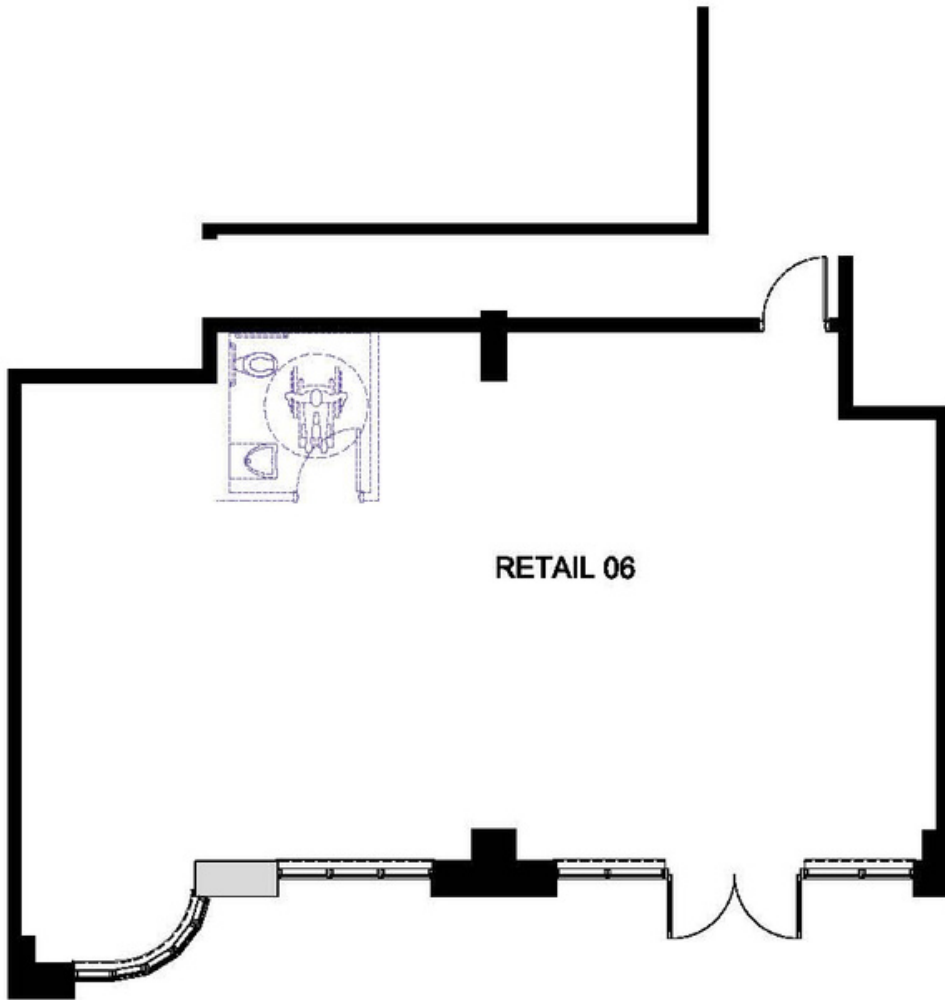



Property Details

Municipal Address:	1704B AVENUE RD. TORONTO, Ontario
Size:	753 SQ FT
Maintenance Fee:	\$689.40 / month
Property Taxes:	TBD (2022)
Asking Price:	<b>\$1,016,550</b>

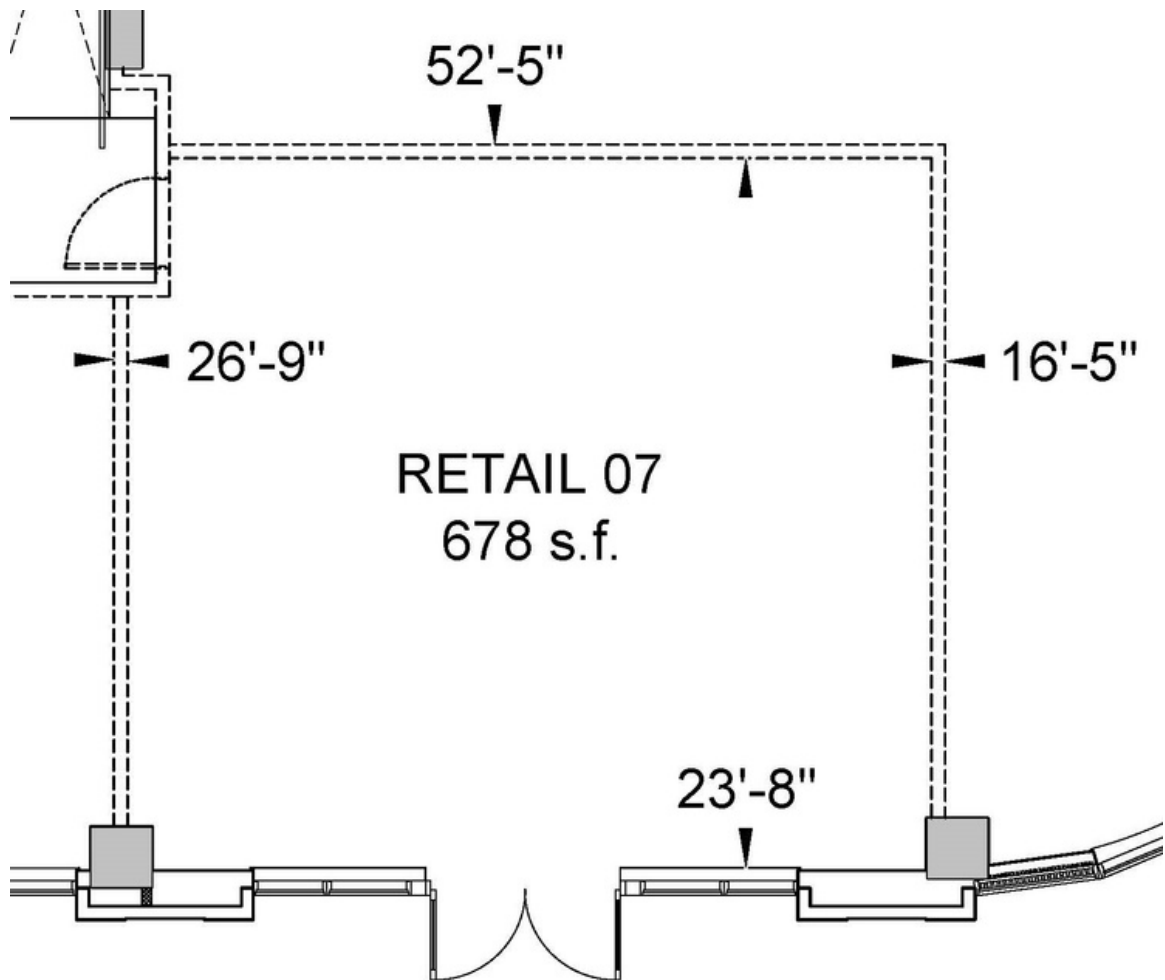





Richard Flomen, Broker of Record

416 406 9959

[rflomen@brixtonre.com](mailto:rflomen@brixtonre.com)

1-71 Villarboit Crescent, Vaughan

416 492 8700

[brixtonre.com](http://brixtonre.com)