

For Sale

10.84± Acre Industrial Lot

2405 E. 85th Street
Kansas City, Missouri



Pat Coppinger
Senior Vice President
+1 816 556 1110
pat.coppinger@colliers.com

Doug Hedrick SIOR, CCIM
Senior Vice President
+1 816 556 1136
doug.hedrick@colliers.com



Accelerating success.

Property Profile

2405 E. 85th Street



Property Features

- Land area: 10.84± acres
- Total building area: 29,951± SF
- Surface lot: majority paved or rocked
- Land use: Industrial
- Industrial park: Dodson Industrial Area
- Location: Excellent highway access
- Taxes: \$25,065 (2023)
- Price: \$2,725,000

1 – Plant Building

- Total size: 21,025± SF
 - Main area: 17,400± SF
 - Storage areas: 2,679± SF
 - Break area: 946± SF
- Clear height: 17'-20'6"
- Power: 1,600 amp; 480/277v; 3-phase
- Loading doors: 7
 - 4 (15'x10') drive in
 - 1 (22'x15') drive in
 - 1 (16'x15') drive in
 - 1 (10'x10') drive in

2 – Shop/Maintenance Building

- Total size: 5,586± SF
- Clear height: 13'-14'
- Column spacing: Clear span
- Lighting: LED
- Power: 255 amp; 480/277v; 3-phase
- Loading doors: 4
 - 2 (15'x10') van high
 - 1 (15'x10') drive in
 - 1 (12'x10') drive in

3 – Office Building

- Total size: 3,340± SF

* Other structures on site serve as covered storage areas.

Floor Plans

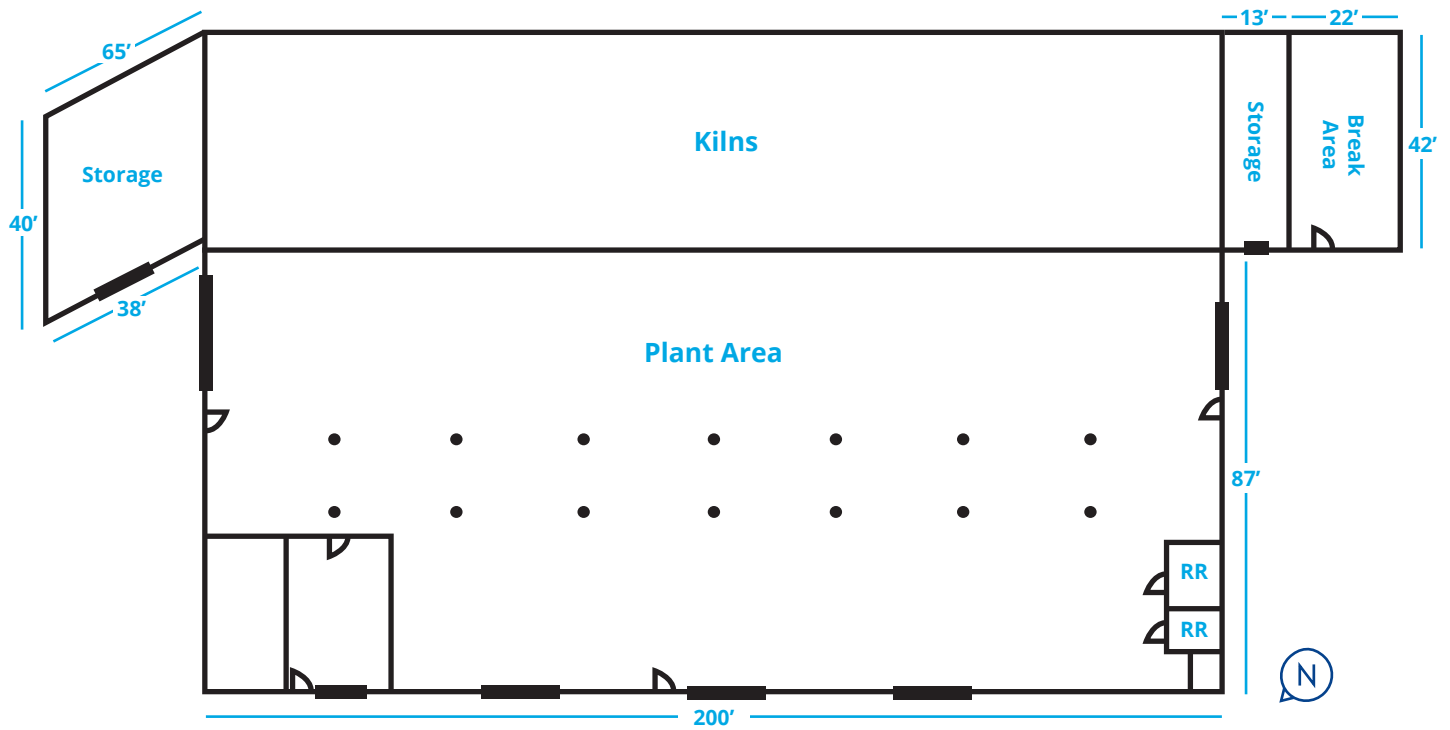

1 - Plant Building

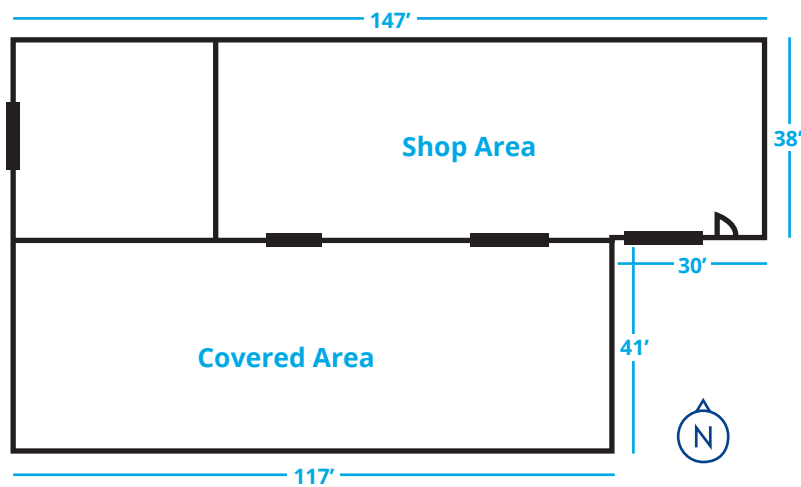

2 - Shop/Maintenance Building

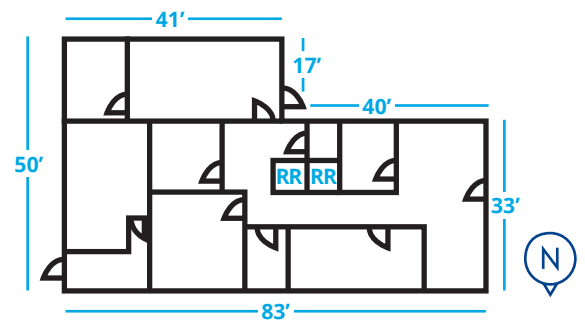

3 - Office Building

*All dimensions estimated

For Sale
2405 E. 85th Street

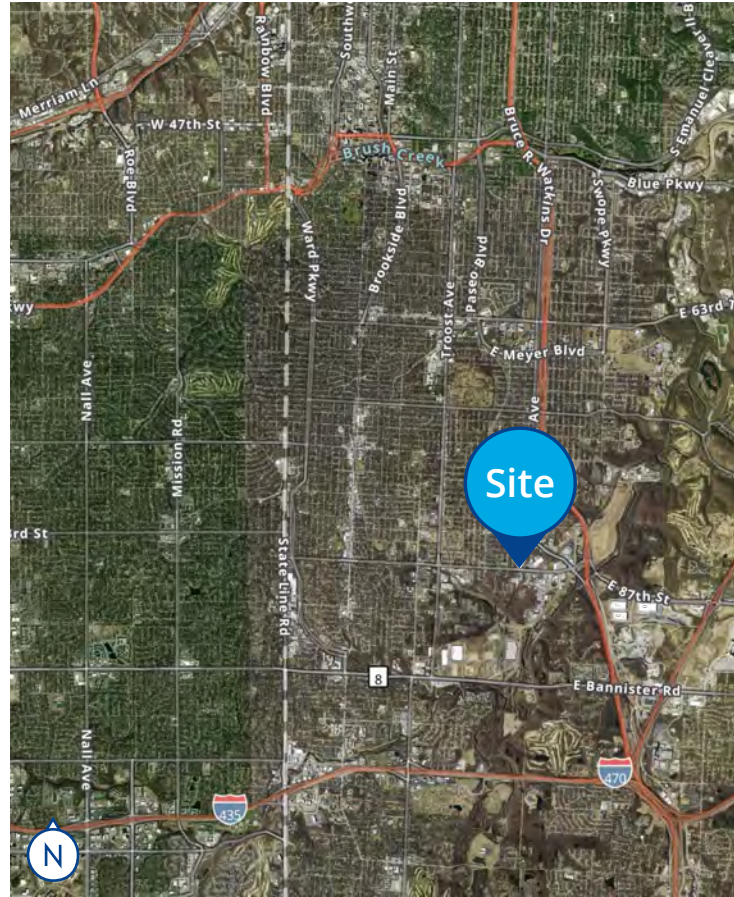

Pat Coppinger
Senior Vice President
+1 816 556 1110
pat.coppinger@colliers.com

Doug Hedrick SIOR, CCIM
Senior Vice President
+1 816 556 1136
doug.hedrick@colliers.com

Colliers Kansas City
4520 Main Street, Suite 1000
Kansas City, MO 64111
+1 816 531 5303
colliers.com/kansascity



This document has been prepared by Colliers for advertising and general information only. Colliers makes no guarantees, representations or warranties of any kind, expressed or implied, regarding the information including, but not limited to, warranties of content, accuracy and reliability. Any interested party should undertake their own inquiries as to the accuracy of the information. Colliers excludes unequivocally all inferred or implied terms, conditions and warranties arising out of this document and excludes all liability for loss and damages arising there from. This publication is the copyrighted property of Colliers and /or its licensor(s). © 2024. All rights reserved. This communication is not intended to cause or induce breach of an existing listing agreement.