

# OFFERING MEMORANDUM

622-640 Oak St | Copiague, New York 11726

## FOR LEASE



Commercial





# EXECUTIVE SUMMARY

622-640 Oak St | Copiague, New York 11726

<b>Building Size:</b>	19,299 SF	<b>Lot Size:</b>	25,000 SF
<b>Available SF:</b>	1,200 - 1,728 SF	<b>Parking:</b>	Spaces
<b>Number of Units:</b>	2	<b>Zoning:</b>	G
<b>Year Built:</b>	1947	<b>Lease Rate:</b>	Priced Upon Request

\*\*\*All information to be verified by prospective tenants.

## Property Overview

Strip Center located on the connecting road of Oak Street... between up and coming towns of Lindenhurst and Copiague. Located in close proximity to both LIRR stations. This center offers parking for 70 cars with access doors from both the rear parking lot and front Oak street. Join other service related retail such as 99 Cent/Discount Store , Physical Therapy, Karate Studio, Laundromat, Hair Salon and Spanish Market/Deli. Great for other service related businesses, office and medical tenants. New residential developments in both towns offer customer flow.

## Property Highlights

- Large Parking Lot
- Easy Access-In and Out
- Centrally Located
- Excellent Opportunity

## Spaces

	Lease Rate	Space Size
<b>622 Oak St., Copiague</b>	Priced Upon Request	1,728 SF
<b>630 Oak St., Copiague</b>	Priced Upon Request	1,200 SF

Exclusively represented by:

### Dennis Gandley

Licensed Real Estate Salesperson  
631.858.2406 Email: dennis.gandley@elliman.com

### Ben Indiviglia

Licensed Real Estate Salesperson  
516.353.6549 Email: ben.indiviglia@elliman.com

# ADDITIONAL PHOTOS

622 Oak St | Copiague, New York 11726

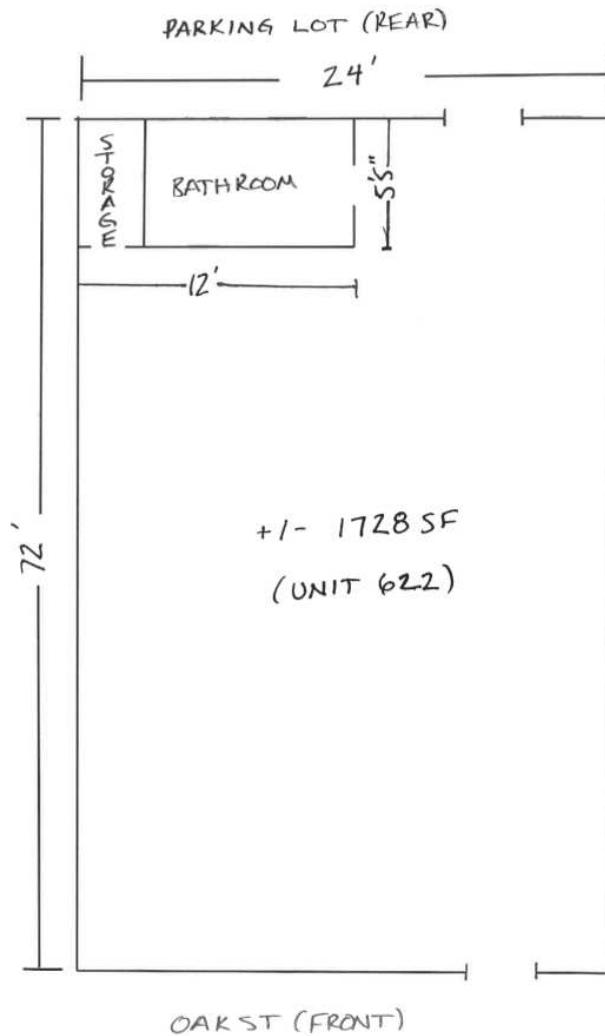

Exclusively represented by:

**Dennis Gandley**

Licensed Real Estate Salesperson  
631.858.2406 Email: dennis.gandley@elliman.com

**Ben Indiviglia**

Licensed Real Estate Salesperson  
516.353.6549 Email: ben.indiviglia@elliman.com



# ADDITIONAL PHOTOS

630 Oak St | Copiague, New York 11726

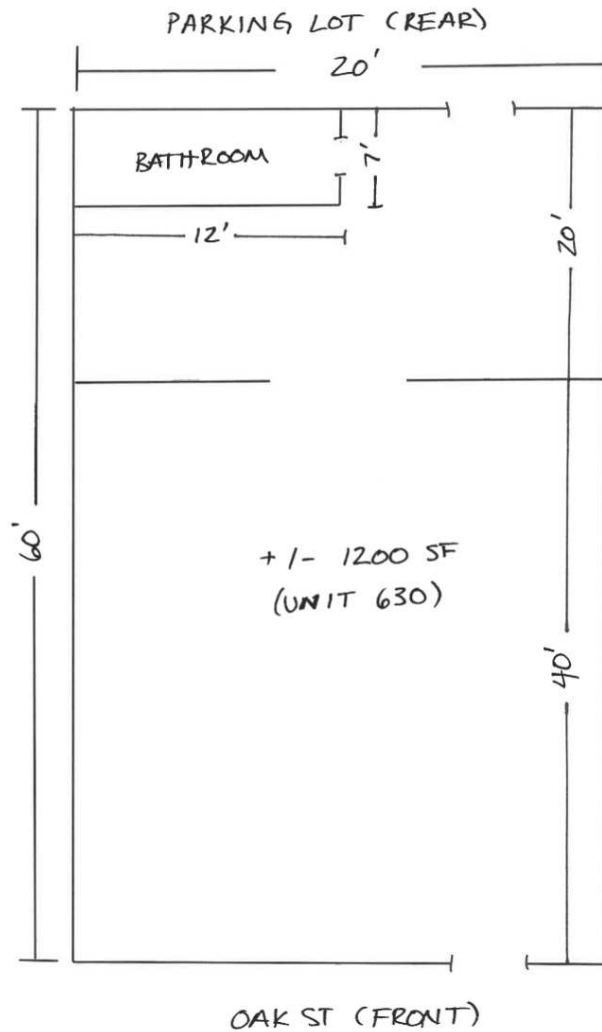

Exclusively represented by:

**Dennis Gandley**

Licensed Real Estate Salesperson  
631.858.2406 Email: dennis.gandley@elliman.com

**Ben Indiviglia**

Licensed Real Estate Salesperson  
516.353.6549 Email: ben.indiviglia@elliman.com



# RETAILER MAP

622-640 Oak St | Copiague, New York 11726

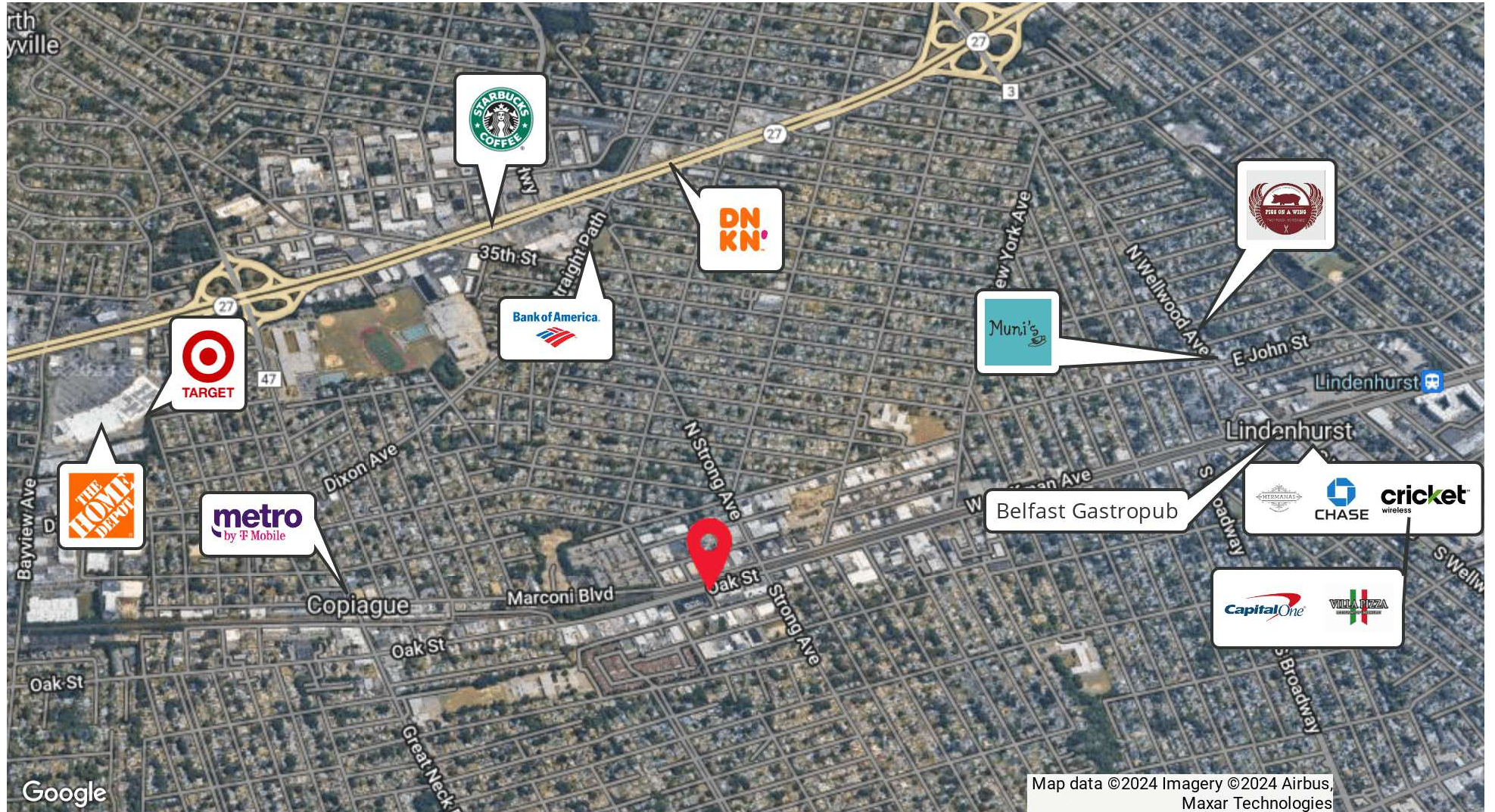

Exclusively represented by:

**Dennis Gandley**

Licensed Real Estate Salesperson  
631.858.2406 Email: dennis.gandley@elliman.com

**Ben Indiviglia**

Licensed Real Estate Salesperson  
516.353.6549 Email: ben.indiviglia@elliman.com



# DEMOGRAPHICS MAP & REPORT

622-640 Oak St | Copiague, New York 11726

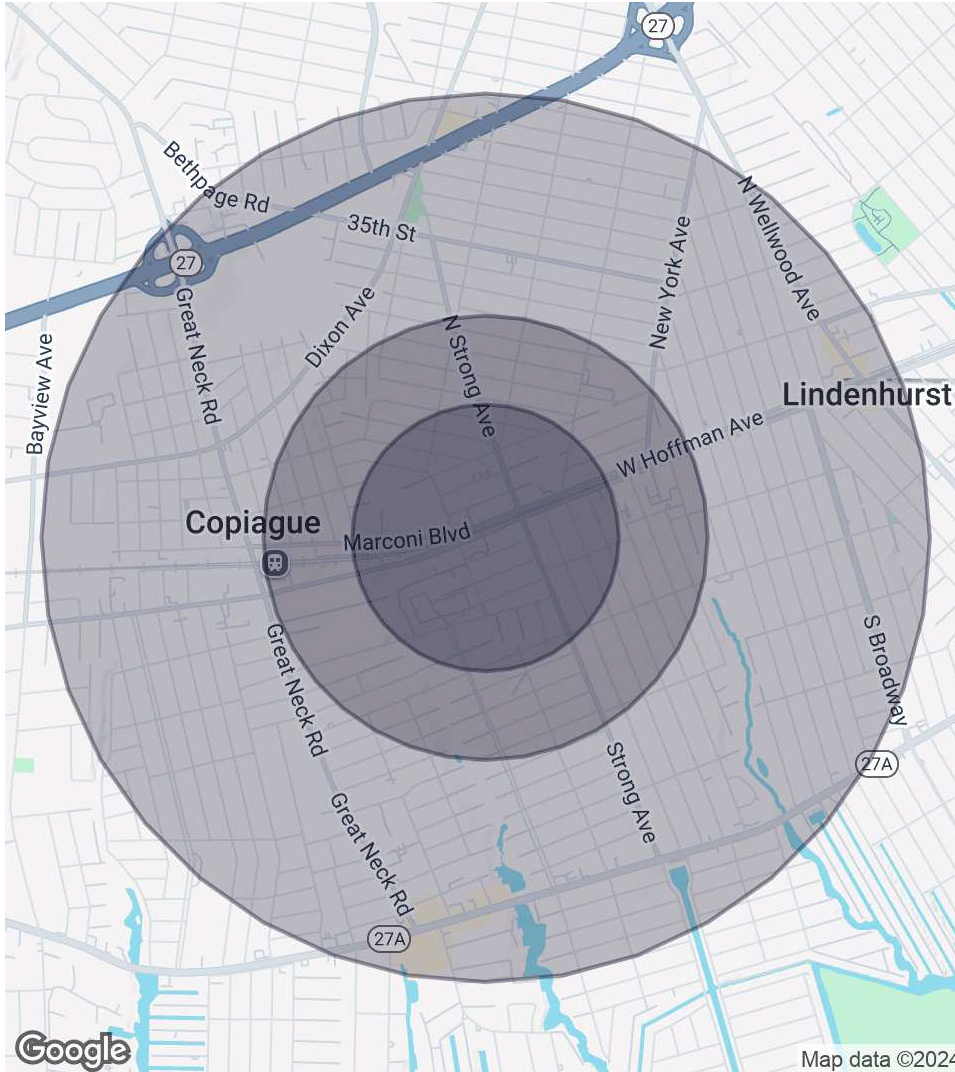

## 0.3 Miles Radius

**Population**  
2,076  
**Households**  
678  
**Average HH Income**  
\$111,134

**Median HH Income**  
-  
**Daytime Population (W/ 16 yr+)**  
-

## 0.5 Miles Radius

**Population**  
6,860  
**Households**  
2,149  
**Average HH Income**  
\$114,364

**Median HH Income**  
-  
**Daytime Population (W/ 16 yr+)**  
-

## 1 Mile Radius

**Population**  
26,286  
**Households**  
8,296  
**Average HH Income**  
\$124,485

**Median HH Income**  
-  
**Daytime Population (W/ 16 yr+)**  
-

Exclusively represented by:

**Dennis Gandley**

Licensed Real Estate Salesperson  
631.858.2406 Email: dennis.gandley@elliman.com

**Ben Indiviglia**

Licensed Real Estate Salesperson  
516.353.6549 Email: ben.indiviglia@elliman.com

622-640 Oak St | Copiague, New York 11726

## EXCLUSIVELY REPRESENTED BY:



**Dennis Gandley**

Licensed Real Estate Salesperson  
631.858.2406  
Email: [dennis.gandley@elliman.com](mailto:dennis.gandley@elliman.com)



**Ben Indiviglia**

Licensed Real Estate Salesperson  
516.353.6549  
Email: [ben.indiviglia@elliman.com](mailto:ben.indiviglia@elliman.com)



550 Smithtown Bypass Suite 117  
Smithtown, NY 11787  
631.858.2405  
[ellimancommercial.com](http://ellimancommercial.com)

# ADVISOR BIO 1

622-640 Oak St | Copiague, New York 11726



## Dennis Gandley

Licensed Real Estate Salesperson

dennis.gandley@elliman.com

Direct: **631.858.2406** | Cell: **631.219.7551**

## Professional Background

Dennis Gandley joined Douglas Elliman in 2012. His own experience as a business owner led him to initially join Douglas Elliman as a Business Broker. Having been involved with the ownership and eventual sales of his own restaurant and bars, Dennis was able to understand the requirements and concerns of business owners who were looking to sell.

After establishing a vast number of contacts from both his personal and business worlds, Dennis eventually began to connect buyers and sellers, landlord and tenants -leading to many successful transactions beyond just business brokerage. Dennis quickly established himself as one of the Top Producing Commercial Real Estate Agents in the Commercial Division.

Over the past decade, Dennis has handled all types of Commercial Real estate transactions, from Landlord Representation for retail, office, medical, industrial spaces and more to selling every type of Commercial property spanning across the Island, from the Hamptons to the Burroughs.

Dennis has positioned himself as one of the most highly referred Commercial Agents within the Commercial Division. Understanding that relationships are one of the most invaluable and important components of business, Dennis has established incredible connections with our residential agents, continually working with many of them across Long Island to facilitate Commercial transactions within the company.

A dedicated Commercial Real Estate expert, Dennis appreciates the opportunity to consistently network amongst his colleagues and counterparts within Elliman and beyond. He looks forward to analyzing, evaluating, and executing plans for each client he represents.

Throughout, his years in the restaurant/bar business he has formed relationships with noteworthy figures in the Long Island business world. Dennis has established himself as a

### Douglas Elliman Commercial - Long Island

550 Smithtown Bypass Suite 117

Smithtown, NY 11787

631.858.2405

*Exclusively represented by:*

## Dennis Gandley

Licensed Real Estate Salesperson

631.858.2406 Email: dennis.gandley@elliman.com

## Ben Indiviglia

Licensed Real Estate Salesperson

516.353.6549 Email: ben.indiviglia@elliman.com



# ADVISOR BIO 2

622-640 Oak St | Copiague, New York 11726



## Ben Indiviglia

Licensed Real Estate Salesperson

ben.indiviglia@elliman.com

Direct: **516.353.6549** | Cell: **516.353.6549**

NY #10401224061

## Professional Background

As a native Long Islander, current resident, and Hofstra Graduate, I have worked in various aspects of retail banking, mortgages, financial services, and real estate. I began my career at The Long Island Savings Bank as a teller while attending college. I continued after graduation with the bank which was purchased by Astoria Federal. I later worked as a team leader in a local call center. I moved on as a Client Financial Analyst with Citibank as they acquired European American Bank and then decided to add to my knowledge base by joining Preferred Empire Mortgage, a local mortgage broker. While observing the mortgage industry grow beyond expectations, I decided to again diversify my experience by leaving the mortgage company in June 2006 and pursued a career as a financial advisor with Investors Capital, a nationwide independent broker/dealer. I obtained my real estate license in order to help people navigate these turbulent times in the real estate market as well. Observing the real estate market locally over the past 15 years has really given insight to what is out there. The combined 30 years of experience allow me to view a client's complete financial scenario from many perspectives. I enjoy being able to help homeowners and business owners make good decisions based on their needs.

### Douglas Elliman Commercial - Long Island

550 Smithtown Bypass Suite 117

Smithtown, NY 11787

631.858.2405

*Exclusively represented by:*

## Dennis Gandley

Licensed Real Estate Salesperson

631.858.2406 Email: dennis.gandley@elliman.com

## Ben Indiviglia

Licensed Real Estate Salesperson

516.353.6549 Email: ben.indiviglia@elliman.com



## We Are Commercial Real Estate

550 Smithtown Bypass Suite 117  
Smithtown, NY 11787  
631.858.2405  
ellimancommercial.com

Commercial real estate involves more than just property listings. To get the most effective results, you need to partner with a company that has a full complement of services and an in-depth team of professionals to help with all your needs. Douglas Elliman's team of commercial real estate experts is committed to unrivaled performance standards when working with tenants, investors, purchasers and owners. We represent all major property types including office, industrial, retail, apartment and land. We treat each assignment with commitment and focus, from a single transaction in a local market to national and multi-market assignments. We help negotiate contracts, coordinate construction and provide both property management as well as ongoing advisory service to satisfy your changing real estate needs. Our breadth of market knowledge, unprecedented network and use of innovative technology extend to all types of property transactions. For information on our services please contact us today.