

704 MAIN STREET  
LONGMONT, CO 80501



Space Available:

1,534 – 6,100 SF

Sale Price:

\$1,500,000\* (\$250/SF)

*\*for sale as-is*

Lease Rate:

Contact broker for details

*PROMINENT BUILDING FOR LEASE OR SALE - LOCATED ALONG MAIN STREET IN LONGMONT*

- Retail building for lease or sale in the heart of Longmont - conceptual demising plans found below
- Located on signalized corner of Main Street and Longs Peak Avenue — 30,775 VPD (2022)
- Ample parking in reserved lot
- Building and monument signage
- T.I. allowance negotiable



# AS-IS BUILDING FLOORPLAN

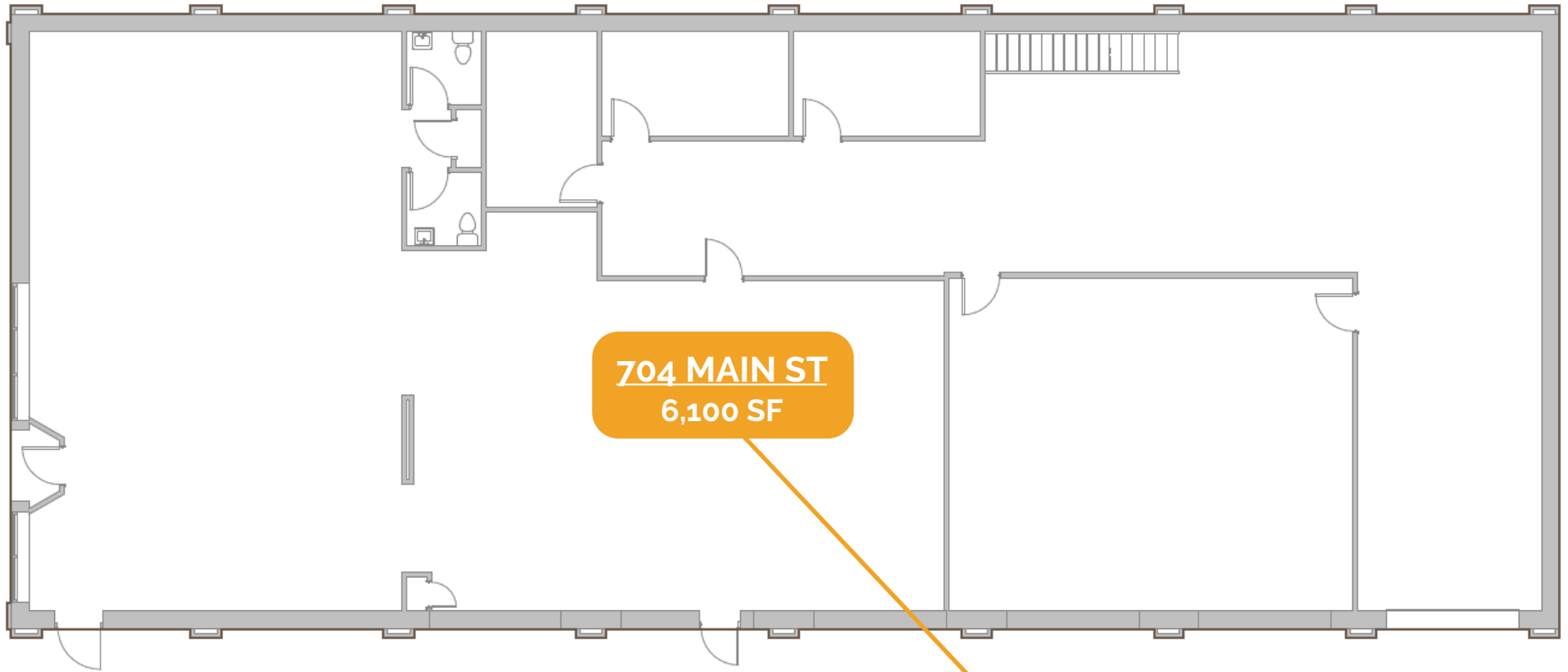

# CONCEPTUAL EXTERIOR RENDERINGS - PATIO FOCUS



**SIGNAGE  
LOCATIONS**



**COVERED  
PATIOS**



**TURF AREA**

# CONCEPTUAL EXTERIOR RENDERINGS - *PARKING FOCUS*



# CONCEPTUAL FLOORPLANS

## Conceptual 2-Tenant Layout

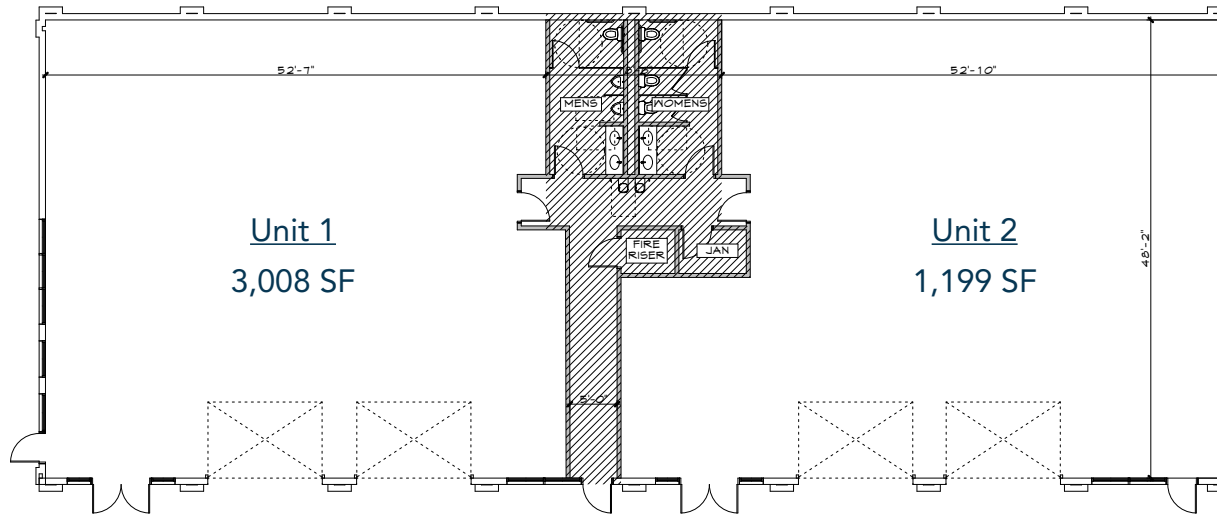

## Conceptual 3-Tenant Layout

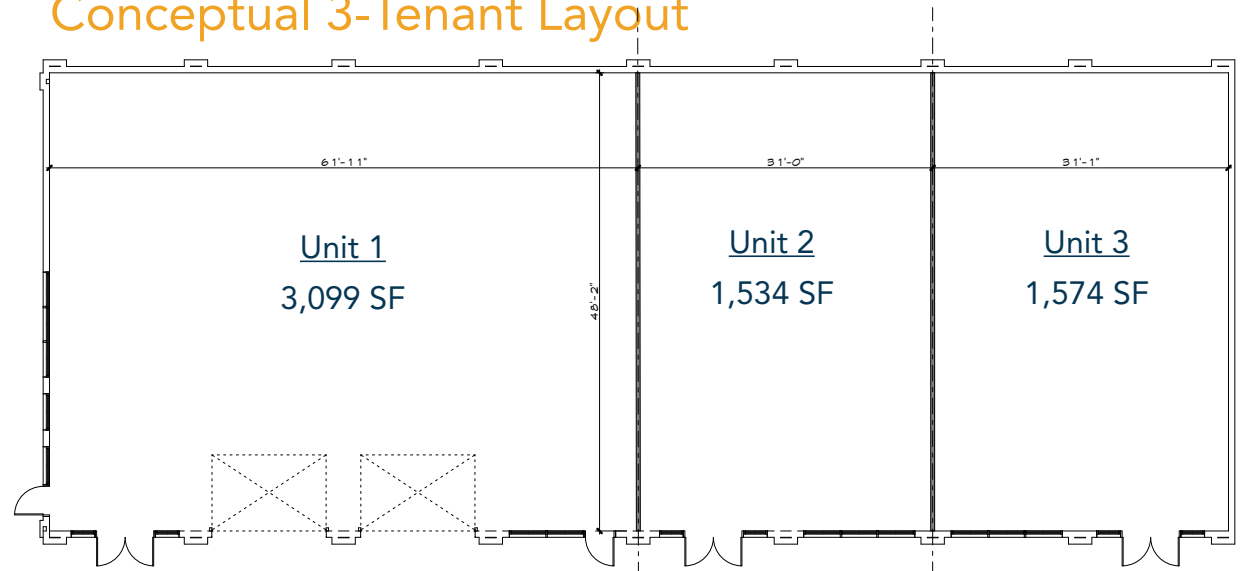

The information contained in this offering has been obtained from sources believed to be reliable; however, the accuracy cannot be guaranteed. All potential buyers and/or tenants are hereby advised to perform their own due diligence and independently verify all of the information set forth herein.

# AREA MAP

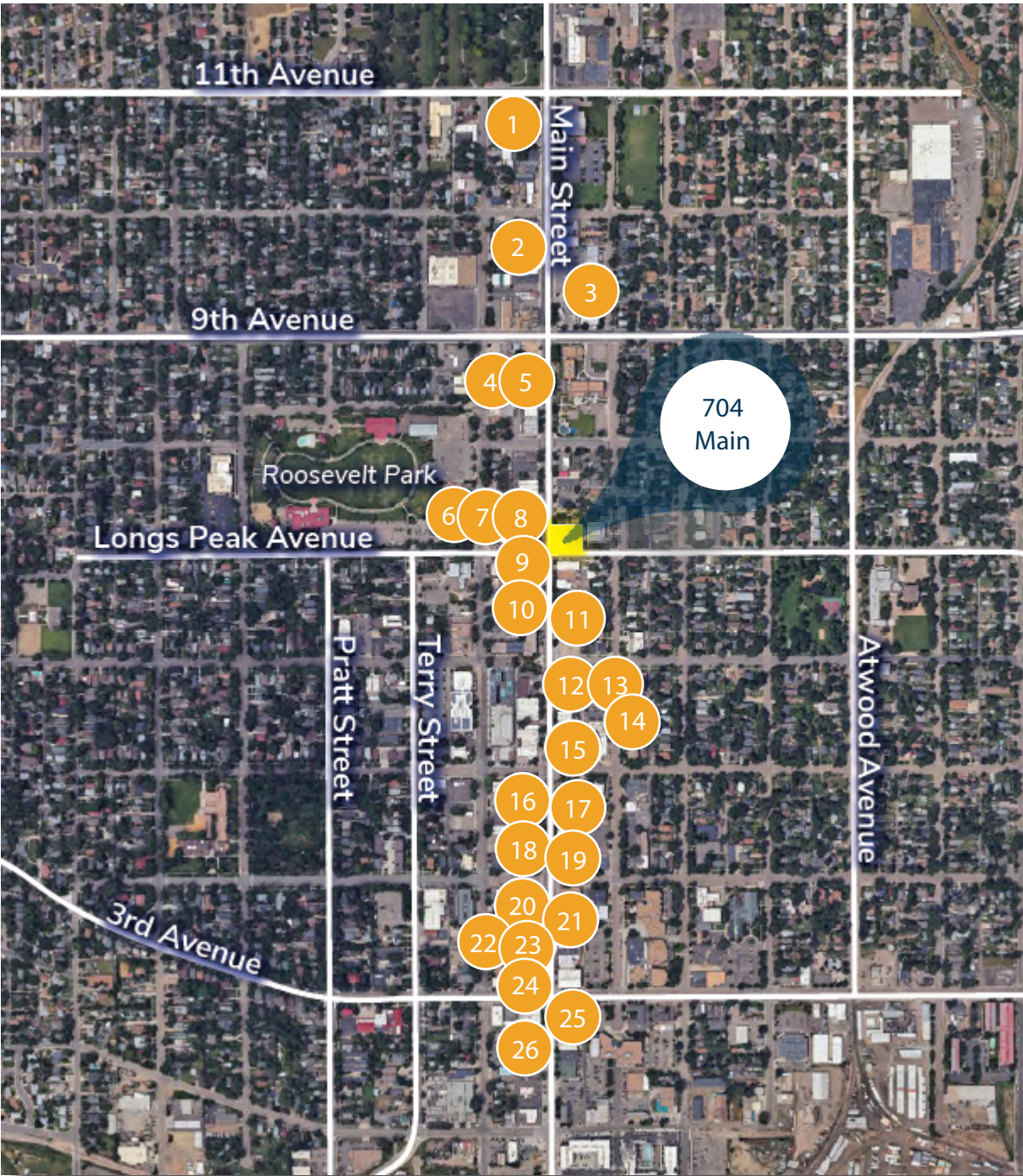

## AREA BARS & RESTAURANTS

- |    |    |
|----|----|
| 1  | 14 |
| 2  | 15 |
| 3  | 16 |
| 4  | 17 |
| 5  | 18 |
| 6  | 19 |
| 7  | 20 |
| 8  | 21 |
| 9  | 22 |
| 10 | 23 |
| 11 | 24 |
| 12 | 25 |
| 13 | 26 |